

ALL MDCAT TOPPERS RECOMMENDS PRACTICE OF MDCAT PAST PAPERS BOOK

YOU MUST PRACTICE BOOK UNIT WISE MDCAT PAST PAPERS 2008-2019



UNIVERSITY OF HEALTH SCIENCES (UHS), LAHORE

MEDICAL COLLEGE APTITUDE TEST (MCAT) PAST PAPERS 2008-2016



MDCAT PAST PAPERS 2008-2019 WITH ANSWER KEY IS VERY IMPORTANT

University of Health Sciences, Lahore



Total MCQs: 220

Max. Marks: 1100

ENTRANCE TEST - 2008

For F.Sc. Students Only

Time Allowed: 150 minutes

Instructions:

- Read the instructions on the MCQs Response Form carefully.
- Choose the **Single Best Answer** for each question.
- Candidates are strictly prohibited from giving any identification mark except Roll No. & Signature in the specified columns only.

COMPULSORY QUESTION FOR IDENTIFICATION

Q-ID. What is the color of your Question Paper?

A) White.

C) Pink.

B)

Blue.

D) Green.

ID

Ans: Colour of your Question Paper is Green.

Fill the Circle Corresponding to Letter 'D' against 'ID' in your MCQ response form (Exactly as shown in the diagram).

	A	B	C	D
1	<input type="radio"/>	<input type="radio"/>	<input type="radio"/>	<input checked="" type="radio"/>
2	<input type="radio"/>	<input type="radio"/>	<input type="radio"/>	<input type="radio"/>
3	<input type="radio"/>	<input type="radio"/>	<input type="radio"/>	<input type="radio"/>
4	<input type="radio"/>	<input type="radio"/>	<input type="radio"/>	<input type="radio"/>

PHYSICS

Q.1 When a helium atom loses an electron, it becomes:

A) An alpha particle.

C) A positive helium ion.

B) Proton.

D) A negative helium ion.

Q.2 Beta ray emitted by a radioactive substance is:

A) An electron which was existing outside the nucleus.

B) An electron which was existing inside the nucleus.

C) An electron emitted by the nucleus as a result of the decay of neutron inside the nucleus.

D) A pulse of electromagnetic wave.

Q.3 An electric charge in uniform motion produces:

A) An electric field.

C) Both magnetic and electric fields.

B) A magnetic field.

D) Neither magnetic nor electric fields.

Q.4 What is emitted by a hot metal filament in a cathode ray tube?

A) X-ray.

C) Electron.

B) Proton.

D) Photon.

Q.5 If the mass of the bob of a pendulum is doubled its time period is:

A) Halved.

C) Unchanged.

B) Doubled.

D) Increases four times.

Q.6 The centre of Newton rings is dark due to:

A) Polarization.

C) Constructive interference.

B) Destructive interference.

D) Reflection.

- Q.7 Which one is most stable element on the basis of binding energy?**
A) Sn. C) Kr.
B) Ba. D) Fe.
- Q.8 Resistance in RC circuit of time constant 2 seconds is 1000 Ohms. What is value of C in the circuit?**
A) 2 μ farad. C) 200 μ farad.
B) 20 μ farad. D) 2000 μ farad
- Q.9 The Lenz's law refers to induced _____**
A) emf. C) Shear.
B) Resistance. D) Currents.
- Q.10 In which of the following, output is similar to NAND gate if input A=0 and input B=1.**
A) NOR. C) XOR.
B) XNOR. D) Both B and C.
- Q.11 For atomic hydrogen spectrum, which of the following series lies in visible region of electromagnetic spectrum?**
A) Lyman series. C) Balmer series.
B) Paschen series. D) Bohr series.
- Q.12 _____ are the particles that experience strong nuclear force.**
A) Electrons. C) Neutrinos.
B) Muons. D) Neutrons.
- Q.13 The vertical velocity of ball thrown upward _____ with time.**
A) Decreases linearly. C) Doubles.
B) Remains constant. D) Decreases parabolically.
- Q.14 The force required to bend the normally straight path of a particle into a circular path is called _____ force.**
A) Traveling. C) Centrifugal.
B) Bending. D) Centripetal.
- Q.15 A disc at rest without slipping, rolls down a hill of height (3 x 9.8) m. What is its speed in m/sec when it reaches at the bottom?**
A) 11.4. C) 22.8.
B) 19.6. D) 9.8.
- Q.16 Tuning of the radio is the best example of electrical _____**
A) Resonance. C) Current.
B) Resistance. D) None of these.
- Q.17 A standing wave pattern is formed when the length of string is an integral multiple of _____ wavelength.**
A) Triple. C) Half.
B) Full. D) Double.
- Q.18 Which of the following lights travels the fastest in optical fibres?**
A) Visible light. C) Ultra-violet.
B) Invisible infra-red. D) Ordinary light.
- Q.19 The algebraic sum of potential changes in a closed circuit is zero is Kirchoff's _____ rule.**
A) First. C) Third.
B) Second. D) None of these.
- Q.20 In LED when an electron combines with a _____ during forward bias conduction, a photon of visible light is emitted.**
A) High voltage. C) Hole.
B) Photon. D) Positron.

- Q.21** For photons of energy greater than 1.02 MeV the probability of pair production occurrence _____ as the energy increases.
- A) Increase. C) Reduces to half.
B) Completely diminishes. D) Remains unchanged.
- Q.22** The neutron is assumed to be made of
- A) One up quark and two down quarks. C) Two up quarks and one down quark.
B) Two up quarks and two down quarks. D) One up quark and one down quark.
- Q.23** An _____ missile is called a ballistic missile.
- A) Un-powered and guided. C) Powered and guided.
B) Un-guided and powered. D) Un-powered and un-guided.
- Q.24** Two cylinders of equal mass are made from same material. The one with the larger diameter accelerates _____ the other under the action of same torque.
- A) Faster than. C) Equal to.
B) Slower than. D) None of these.
- Q.25** The angular frequency of simple pendulum is directly proportional to _____
- A) l . C) $v l$.
B) $1/l$. D) $v1/l$.
- Q.26** Two waves of slightly different frequencies and traveling in same direction produce _____
- A) Interference. C) Stationary waves.
B) Polarization. D) Beats.
- Q.27** A single mode step index fibre has core of about _____ μm diameter
- A) 50 to 1000. C) 30.
B) 50. D) 5.
- Q.28** A 5 Ohm resistor is indicated by a single _____ color band around its body.
- A) Red. C) Blue.
B) Green. D) Brown.
- Q.29** Practically _____ current flows in a reverse biased p-n junction.
- A) No. C) Few milliamperes.
B) Very large. D) Both A and C.
- Q.30** Cesium coated oxidized silver emits electrons for _____ light.
- A) Infrared. C) Visible.
B) Ultraviolet. D) Green.
- Q.31** The cobalt is absorbed by
- A) Bones. C) Liver.
B) Skin. D) Thyroid gland.
- Q.32** In a step-down transformer the output current _____
- A) Is reduced. C) Remains same.
B) Is increased. D) None of these.
- Q.33** Force in terms of base units is expressed as
- A) kg ms^{-2} . C) $\text{kg m}^2\text{s}^{-3}$.
B) $\text{kg m}^2\text{s}^{-2}$. D) None of these.
- Q.34** 100 joules work has been done by an agency in 10 seconds. What is power of agency?
- A) 1000 watt. C) 10 watt.
B) 100. D) 0.10 watt.
- Q.35** The acceleration is proportional to the displacement and is directed towards mean position in _____ motion.
- A) Gravity. C) Uniform.
B) Simple harmonic. D) Projectile.

- Q.36** In gases, the speed of sound is inversely proportional to _____ of the density when other factors are same.
A) Square root. C) Third power.
B) Square. D) Third root.
- Q.37** A watch maker uses _____ to repair the watches.
A) Telescope. C) Convex lens.
B) Convex mirror. D) Concave lens.
- Q.38** A 2m long pipe is open at both ends. What is its harmonic frequency?
A) 42.5 Hz. C) 220 Hz.
B) 85 Hz. D) None of these.
- Q.39** A wire has resistance 100 Ohm at 0 °C and 200 Ohm at 100 °C. What is its temperature coefficient in K⁻¹?
A) -0.01. C) 0.01.
B) -1/273. D) 1/273.
- Q.40** The net magnetic field created by the electrons within an atom is due to the field created by their _____ motion.
A) Orbital. C) Orbital & spin.
B) Spin. D) Orbital x spin.
- Q.41** At high temperature, the proportion of _____ wavelength radiation increase.
A) AM radio. C) Shorter.
B) Long radio. D) Both A and C.
- Q.42** In photoelectric effect removal of photons is observed at _____ energies.
A) Low. C) Intermediate.
B) High. D) Both A and C.
- Q.43** Which device is the most efficient?
A) Nuclear reactor. C) Silicon solar cell.
B) Storage battery. D) Dry battery cell.
- Q.44** The units of E in E=mc² are
A) kg m s⁻². C) kg m² s⁻².
B) N m s⁻². D) Both B and C.
- Q.45** Work done on a body equals change in its _____ energy.
A) Total. C) Kinetic.
B) Potential. D) All of these.
- Q.46** A pipe varies uniformly in diameter from 2 m to 4 m. An incompressible fluid enters the pipe with velocity 16m/sec. What is velocity of fluid when it leaves the pipe?
A) 64 m/sec. C) 8 m/sec.
B) 32 m/sec. D) 4 m/sec.
- Q.47** Transverse waves cannot be setup in _____
A) Metals. C) Fluids.
B) Solids. D) Soil.
- Q.48** The ratio of the _____ is called magnification.
A) Image size to object size. C) Eyepiece size to object size.
B) Object size to image size. D) None of these
- Q.49** Which of the following has the highest resistivity?
A) Germanium. C) Copper.
B) Silver. D) Platinum.
- Q.50** An n-type semi-conductor is made by doping silicon crystal with _____
A) Indium. C) Arsenic.
B) Aluminium. D) Both B and C.

- Q.51** Objects cannot be accelerated to the speed of light in free space is consequence of
 A) Mass variation. C) Inertia forces.
 B) Energy-mass relationship. D) All of these.
- Q.52** A certain radioactive mass decays from 64 gm to 2 gm in 20 days. What is its half-life?
 A) 5 days. C) 10 days.
 B) 4 days. D) 6 days.
- Q.53** If inductance is denoted by L and resistance by R, which of the following is true for a choke?
 A) R is large, L is very small. C) Both R and L are large.
 B) R is very small, L is large. D) Both R and L are very small.
- Q.54** A force $2i + j$ has moved its point of application from (2,3) to (6,5). What is work done?
 A) -10. C) -18.
 B) +10. D) +18.
- Q.55** The escape velocity corresponds to _____ energy gained by body, which carries it to an infinite distance from the surface of earth.
 A) Total. C) Initial kinetic.
 B) Potential. D) None of these.
- Q.56** The drag force decreases as the speed of an object moving through fluid _____
 A) Increases. C) Remains constant.
 B) Decreases. D) Both B and C.
- Q.57** Light year is a measure of
 A) Distance. C) Intensity of light.
 B) Time. D) Velocity.
- Q.58** A yellow light of wavelength 500 nm emitted by a single source passes through two narrow slits 1 mm apart. How far apart are two adjacent bright fringes when interference is observed on a screen 10 m away?
 A) 5 mm. C) 0.5 mm.
 B) 1.33 mm. D) 50 mm.
- Q.59** The heat produced by a current I in the wire of resistance R during time interval t is
 A) I^2/Rt . C) I^2R/t .
 B) I^2Rt . D) IR^2t .
- Q.60** Which of the following is the most ductile?
 A) Glass. C) Cast iron.
 B) Copper. D) High carbon steel.

CHEMISTRY

- Q.61** Which type of bonding is present in NH_4Cl ?
 A) Ionic. C) Coordinate covalent.
 B) Covalent. D) All of these.
- Q.62** When $CuSO_4$ is electrolyzed in aqueous solution using copper electrodes, then the substance which deposits at the cathode is:
 A) Copper metal. C) Hydrogen.
 B) Copper ions. D) Oxygen.
- Q.63** Aldehydes can be synthesized by the oxidation of
 A) Primary alcohols. C) Organic acids.
 B) Secondary alcohols. D) Inorganic acids.
- Q.64** The products of the fermentation of a sugar are ethanol and
 A) Water. C) Carbon dioxide.
 B) Oxygen. D) Sulfur dioxide.

- Q.65** _____ serve as carriers of heredity from one generation to the other.
 A) Lipids. C) Formaldehydes.
 B) Caseins. D) Nucleoproteins.
- Q.66** _____ extraction is controlled by partition law.
 A) Iodine. C) Solvent.
 B) Benzoic acid. D) Stationery.
- Q.67** The process of effusion is best understood by _____ law.
 A) Graham's. C) Boyle's.
 B) Charles's. D) None of these.
- Q.68** _____ has dipole moment.
 A) CO. C) Benzene.
 B) CO₂. D) All of these.
- Q.69** _____ is used as catalyst in Haber's process for NH₃ gas manufacture.
 A) Iron. C) Copper.
 B) Carbon. D) Silver.
- Q.70** In many of its properties _____ is quite different from the other alkali metals.
 A) Li. C) Na.
 B) Be. D) K.
- Q.71** Which element forms long chains alternating with oxygen?
 A) Carbon. C) Nitrogen.
 B) Silicon. D) All of these.
- Q.72** The percentage of carbon in medium carbon steel is
 A) 0.7-1.5. C) 0.2-0.7.
 B) 0.1-0.2. D) 1.6-2.00.
- Q.73** Name the rare halogen among the following.
 A) F. C) I.
 B) Cl. D) At.
- Q.74** Which bond will break when electrophile attacks an alcohol?
 A) O - H. C) Both A and B.
 B) C - O. D) None of these.
- Q.75** The extent of un-saturation in a fat is expressed as its
 A) Acid number. C) Saponification number.
 B) Iodine number. D) None of these.
- Q.76** The process of filtration is used to separate _____ particles from liquids.
 A) Radial. C) Insoluble.
 B) Angular. D) Soluble.
- Q.77** London forces are very significant in _____
 A) Sulphur. C) Argon.
 B) Phosphorous. D) Sugar.
- Q.78** Which of the following formation is endothermic reaction?
 A) $2\text{H}_2(\text{g}) + \text{O}_2(\text{g}) \longrightarrow 2\text{H}_2\text{O}(\text{l})$. C) $\text{N}_2(\text{g}) + \text{O}_2(\text{g}) \longrightarrow \text{N}_2\text{O}_2(\text{g})$.
 B) $\text{C}(\text{s}) + \text{O}_2(\text{g}) \longrightarrow \text{CO}_2(\text{g})$. D) None of these.
- Q.79** Name the partially miscible liquids from the following?
 A) Alcohol-ether. C) Benzene-water.
 B) Nicotine-water. D) Both A and B.
- Q.80** AlI₃ (Aluminium Iodide) is electrically a _____
 A) Conductor. C) Semiconductor.
 B) Non-conductor. D) None of these.

- Q.81** The elements of IIIA to VIIIA subgroups except He are known as _____ block elements.
- A) q. C) p.
B) s. D) None of these.
- Q.82** Concentrated nitric acid gives _____ when it reacts with tin.
- A) Nitric oxide. C) Ammonium nitrite.
B) Meta stannic acid. D) None of these.
- Q.83** Sulphuric acid is used to manufacture
- A) HCl and HNO₃. C) Both A and B.
B) H₃PO₄. D) Both HCl and 2COOH.
- Q.84** Alkanes containing _____ carbon atoms are waxy solids.
- A) up to 4. C) 18 or more.
B) 5 to 17. D) None of these.
- Q.85** Which of the following is used to make chloral hydrate?
- A) Acetaldehyde. C) None of these.
B) Formaldehyde. D) Both A and B.
- Q.86** Ten moles of hydrogen are allowed to react with 6 moles of oxygen. How much water will be obtained from reaction on complete consumption of one gas?
- A) 10 moles. C) 6 moles.
B) 8 moles. D) 4 moles.
- Q.87** The highest temperature a substance can exist as _____ is called its critical temperature.
- A) Solid. C) Gas.
B) Liquid. D) Isotope.
- Q.88** _____ hybridization leads to a regular tetrahedral structure.
- A) sp³. C) sp.
B) sp². D) All of these.
- Q.89** Osmotic pressure of a solution is _____ property.
- A) Obligative. C) Colligative.
B) Fractional. D) Automated.
- Q.90** Magnesium reacts with hydrogen at high pressure in the presence of catalyst _____ forming magnesium hydride.
- A) Dolomite. C) Mg₃N₂.
B) MgI₂. D) Epsom salt.
- Q.91** Which element has the largest number of allotropic forms?
- A) Phosphorous. C) Oxygen.
B) Sulphur. D) Both A & C.
- Q.92** With increase in number of unpaired electrons, paramagnetism:
- A) Increases. C) Remains constant.
B) Decreases. D) Decreases then increases.
- Q.93** Which metal is commonly used to remove air bubbles from molten metals?
- A) Aluminium. C) Sodium.
B) Copper. D) Calcium.
- Q.94** Which of the following bonds has minimum bond energy?
- A) C - F. C) C - I.
B) C - Cl. D) C - Br.
- Q.95** Which of the following does not react with water?
- A) Li. C) Mg
B) Na. D) Be.

- Q.96** $\text{Al}_2\text{O}_3(\text{SiO}_2)_2 \cdot 2\text{H}_2\text{O}$ is called
 A) Clay. C) Asbestos.
 B) Talc. D) None of these.
- Q.97** CaO forms fertilizer slag by reacting with
 A) P_2O_5 . C) Silica.
 B) Fe_2O_3 . D) FeO .
- Q.98** _____ is colorless volatile liquid at room temperature.
 A) HCl . C) HI .
 B) HF . D) HBr .
- Q.99** Hydrogen passed through phenol at 150°C in the presence of _____ catalyst gives cyclohexanol.
 A) Tin. C) Iron.
 B) Nickel. D) Sodium.
- Q.100** Ethanol-water is _____ mixture.
 A) Azeotropic. C) Benedict's.
 B) Ideal. D) Aliphatic.
- Q.101** The mobile phase in paper chromatography is usually
 A) An organic liquid. C) Water.
 B) Sulphuric acid. D) Silver nitrate.
- Q.102** The amount of heat absorbed by one mole of solid at 1 atm when it melts into liquid form is denoted by _____
 A) ΔH_v . C) ΔH_i .
 B) ΔH_f . D) ΔH_s .
- Q.103** In synthetic fibres _____ bonding is responsible for tensile strength.
 A) Nitrogen. C) Oxygen.
 B) Hydrogen. D) None of these.
- Q.104** Boiling point of HF is _____ H_2O .
 A) Lower than. C) Equal to.
 B) Higher than. D) Almost same as.
- Q.105** _____ is necessary for development of leaves and it tends to accumulate in leaves and bark.
 A) NO_2 . C) Gypsum.
 B) Calcium. D) Nitrogen.
- Q.106** Which of the following is pale yellow to reddish yellow in color?
 A) Pb_2O . C) PbO .
 B) PbO_2 . D) $2\text{PbCO}_3 \cdot \text{Pb}(\text{OH})_2$.
- Q.107** In which of the following carbon is double bonded with itself?
 A) Alkane. C) Alkene.
 B) Ether. D) Alkyne.
- Q.108** In this process, higher hydrocarbons can be cracked at lower temperature and lower pressure.
 A) Thermal cracking. C) Steam cracking.
 B) Catalytic cracking. D) Reforming.
- Q.109** Acetic acid is called _____ acid.
 A) Methanoic. C) Ethanoic.
 B) Propanoic. D) Butanoic.
- Q.110** Na may be denoted by _____ electron configuration notation
 A) $1s^2 2s^1$. C) $[\text{Ne}] 3s^1$.
 B) $[\text{Ar}] 4s^1$. D) None of these.

- Q.111 Which is the best drying agent in desiccators?**
 A) KOH. C) CaCl₂.
 B) Gypsum. D) Silica sand.
- Q.112 100 m³ of a gas at 3 atm pressure and 27 °C is transferred to a chamber of 300 m³ volume maintained at a temperature of 327 °C. What will be the pressure in chamber?**
 A) 6 atm. C) 2 atm.
 B) 4 atm. D) 1 atm.
- Q.113 The crystals of _____ are ionic solids.**
 A) Sugar. C) Diamond.
 B) Iron. D) NaCl.
- Q.114 Which material possesses the highest pH?**
 A) Soft drinks. C) Milk of magnesia.
 B) Bananas. D) Sea water.
- Q.115 The electron present in a particular orbit _____ energy.**
 A) Releases. C) Absorbs.
 B) Does not radiate. D) None of these.
- Q.116 Al₂F₂SiO₄ is named as**
 A) Gibbsite. C) Bauxite.
 B) Emerald. D) Cryolite.
- Q.117 Name the oxide in which N has the highest oxidation number.**
 A) Nitrous oxide. C) Nitrogen peroxide.
 B) Nitric oxide. D) Nitrous anhydride.
- Q.118 Sulphur has oxidation state of _____**
 A) ± 2. C) None of these.
 B) + 4 and +6. D) Both A and B.
- Q.119 CH₃-O-CH₃ is example of _____ isomerism.**
 A) Metamerism. C) Chain.
 B) Functional group. D) Position.
- Q.120 _____ are product of reaction of an alcohol and aromatic bi-functional acids.**
 A) Acrylic resins. C) PVCs.
 B) Polyester resins. D) Polyamide resins.

ENGLISH

- Q.121 He was _____ of all valuable possessions.**
 A) Robbed. C) Pinched.
 B) Stolen. D) Established.
- Q.122 The presence of armed guards _____ us from doing anything disruptive.**
 A) Defeated. C) Irritated.
 B) Excited. D) Prevented.
- Q.123 Our flight was _____ from Lahore to Islamabad airport.**
 A) Diverted. C) Deflected.
 B) Reflected. D) Shifted.
- Q.124 I am _____ forward to our picnic scheduled in next month.**
 A) Looking. C) Seeing.
 B) Planning. D) Going.



SPOT THE ERROR: In the following sentences, some segments of each sentence are underlined. Your task is to identify that underlined segment of the sentence, which contains the mistake that needs to be corrected. Fill the Circle corresponding to that letter under the segment in the MCQ Response Form.

- Q.125** They did not guess how closely he had kept in touch with across the road.
A) B) C) D)
- Q.126** He proved that if only germs were excluded of wounds, inflammation was averted.
A) B) C) D)
- Q.127** The man felt his hair flutter and the tissues of his body drew tight as if he were standing at the centre of a vacuum.
A) B) C) D)
- Q.128** He came to the hurdles that he remember, over which once he had so easy a victory.
A) B) C) D)
- Q.129** What is meant by birth-rate and death-rate and how do they effect the population?
A) B) C) D)
- Q.130** She had left him with a calmness and a poise that accord well with his own inward emotions.
A) B) C) D)



In each of the following question, four alternative sentences are given. Choose the CORRECT one and fill the Circle corresponding to that letter in the MCQ Response Form.

- Q.131**
A) He lacked both the training and the equipment needed in the job.
B) He lacked both the training and the equipment needed by the job.
C) He lacked both the training and the equipment needed on the job.
D) He lacked both the training and the equipment needed for the job.
- Q.132**
A) They tried to pacify him for kindness and affection. C) They tried to pacify him by kindness and affection.
B) They tried to pacify him in kindness and affection. D) They tried to pacify him with kindness and affection.
- Q.133**
A) Then he sat down in corner and remained quiet. C) Then he sat down in corner and remain quiet.
B) Then he sat down in corner and remained quite. D) Then he sat down in corner and remained quiet.
- Q.134**
A) He was drenched with the hotness of his fear. C) He was drenched by the hotness of his fear.
B) He was drenched in the hotness of his fear. D) He was drenched off the hotness of his fear.
- Q.135**
A) Why did you disagree with me? C) Why did you disagree on me?
B) Why did you disagree to me? D) Why did you disagree by me?
- Q.136**
A) Do not stuff your head by things you do not understand.
B) Do not stuff your head with things you do not understand.
C) Do not stuff your head for things you do not understand.
D) Do not stuff your head in things you do not understand.
- Q.137**
A) A day later he reached his first glimpse of Lahore.
B) A day later he took his first glimpse of Lahore.
C) A day later he found his first glimpse of Lahore.
D) A day later he caught his first glimpse of Lahore.

Q.138

- A) This will have a bad impact to the economy. C) This will have a bad impact at the economy.
 B) This will have a bad impact on the economy. D) This will have a bad impact over the economy.

Q.139

- A) It would save him from dying of thirst. C) It would save him from dying with thirst.
 B) It would save him from dying from thirst. D) It would save him from dying by thirst.

Q.140

- A) All this flashed by his mind in an instant of protest.
 B) All this flashed on his mind in an instant of protest.
 C) All this flashed through his mind in an instant of protest.
 D) All this flashed by off mind in an instant of protest.



In each of the following question, four alternative meanings of a word are given. You have to select the NEAREST CORRECT MEANING of the given word and fill the appropriate Circle on the MCQ Response Form.

Q.141

VEXING

- A) Annoying. C) Viable.
 B) Aggressive. D) Waxy.

Q.142

VAGUE

- A) Respectful. C) Warlock.
 B) Uncertain. D) Snow white.

Q.143

MANGLED

- A) Dodged. C) Indisputable.
 B) Grained. D) Damaged.

Q.144

PRODIGIOUS

- A) Productive. C) Prudential.
 B) Enormous. D) Waddle.

Q.145

ASTOUNDED

- A) Shocked. C) Assured.
 B) Discarded. D) Attracted.

Q.146

SAGACITY

- A) Foolishness. C) Onions.
 B) Large City. D) Wisdom.

Q.147

GRIM

- A) Gratis. C) Severe.
 B) Restless. D) Grater.

Q.148

INDOLENTLY

- A) Lazily. C) Ideally.
 B) Indecently. D) Gaily.

Q.149

PERISH

- A) Furious. C) Secret.
 B) Come to death. D) Frustrated.

Q.150

DOZE

- A) Dogged. C) Sleep.
 B) Diet. D) Medicine to be taken.

BIOLOGY

Q.151

Which of the following receptors produce sensation of pain?

- A) Mechanoreceptor. C) Chemoreceptors.
 B) Nociceptors. D) Thermoreceptors.

Q.152 When your finger accidentally gets caught in a door, the pain message is sent to your brain through _____

- A) Homeostasis.
- B) Sensory receptors.
- C) Caffeine.
- D) The medulla.

Q.153 Neck has _____ type of joint.

- A) Ball and socket.
- B) Pivot.
- C) Hinge.
- D) Fibrous.

Q.154 End product of hemoglobin break down is:

- A) Creatinine.
- B) Bilirubin.
- C) Hypoxanthin.
- D) Xanthin.

Q.155 In what direction, can a DNA polymerase work when catalyzing the addition of nucleotide monomers to build a strand of DNA?

- A) From the 5' toward the 3' end of the new strand being assembled.
- B) From the replication centers in two directions called replication forks.
- C) From the 3' to the 5' end of the strand being assembled.
- D) In both directions if DNA ligase is present.

Q.156 Which bond is the potential source of chemical energy for cellular activities?

- A) C-N.
- B) C-O.
- C) C-H.
- D) H-O.

Q.157 Sharks and rays are included in class:

- A) Cyclostomata.
- B) Chondrichthyes.
- C) Osteichthyes.
- D) Tetrapoda.

Q.158 In what stage of aerobic respiration are 2-carbon molecules oxidized completely to carbon dioxide?

- A) Glycolysis.
- B) ETC.
- C) Krebs cycle.
- D) Calvin cycle.

Q.159 Which of the following does not have specialized respiratory organs?

- A) Hydra.
- B) Birds.
- C) Cockroach.
- D) Both A and B.

Q.160 Humming birds belong to the category _____

- A) Heterotherms.
- B) Endotherms.
- C) Ectotherms.
- D) None of these.

Q.161 Syphilis is caused by _____

- A) Neisseria gonorrhoeae.
- B) Cats worm.
- C) Treponema pallidum.
- D) Herpes simplex.

Q.162 In moths' male is _____

- A) Heterogametic.
- B) Dieogametic.
- C) Homogametic.
- D) Both B and C.

Q.163 When carbon dioxide pressure increases the capacity of haemoglobin to hold oxygen:

- A) Increases many folds.
- B) Decreases.
- C) Remains constant.
- D) Is doubled.

Q.164 The soluble part of the cytoplasm is termed as _____

- A) Cisternae.
- B) Cytosol.
- C) Endocytosis.
- D) Both A and B.

Q.165 Name the enveloped RNA virus that causes infusion hepatitis.

- A) HBV.
- B) HAV.
- C) HCV.
- D) None of these.

Q.166 In general, asexual reproduction is common in _____

- A) Humans.
- B) Basidiomycota.
- C) Deuteromycota.
- D) Basidiospores.

- Q.167 Name the vertebrates which are without jaws.**
 A) Osteichthyes. C) Chondrichthyes.
 B) Cyclostomata. D) None of these.
- Q.168 The total inside capacity of lungs of adult human beings when fully inflated is**
 A) 5 ml. C) 500 ml.
 B) 50 ml. D) 5000 ml.
- Q.169 Which of the following belong to collenchyma cells?**
 A) Fibers. C) Sclereides.
 B) Vessels. D) None of these.
- Q.170 Which of the following promotes both leaf and fruit growths?**
 A) Auxins. C) Abscisic acid.
 B) Gibberellins. D) Ethane.
- Q.171 Name the external factor of growth in plants**
 A) Carbon dioxide. C) Hormones.
 B) Water. D) Nutrition.
- Q.172 The genes of blue opsin are present on**
 A) Autosome 9. C) Autosome 1.
 B) Autosome 7. D) Autosome 3.
- Q.173 The dew drops on tips of grass leaves is an example of**
 A) Infestation. C) Exudation.
 B) Bleeding. D) Imbibition.
- Q.174 Which of the following modifies proteins and lipids by adding carbohydrates?**
 A) Golgi Apparatus. C) Plasma membrane.
 B) Polysome. D) None of these.
- Q.175 Which of the following are spiral-shaped bacteria?**
 A) Cocci. C) Pseudomonas.
 B) Bacilli. D) Vibrio.
- Q.176 Which of the following is used for lowering blood cholesterol?**
 A) Neurospora. C) Aspergillus.
 B) Griseofulvin. D) Lovastatin.
- Q.177 Which of the following are called placental mammals?**
 A) Prototheria. C) Metatheria.
 B) Eutheria. D) All of these.
- Q.178 The attraction among water molecules which hold water together is called**
 A) Tension. C) Cohesion.
 B) Adhesion. D) Ambibition.
- Q.179 Pick the paratonic movement from the following**
 A) Nastic. C) Growth.
 B) Turgor. D) Tactic.
- Q.180 It controls the several automatic functions like breathing, heart rate and blood pressure:**
 A) Midbrain. C) Medulla.
 B) Pons. D) Cerebellum.
- Q.181 Which of the following has 40 chromosomes?**
 A) Corn. C) Frog.
 B) Sugarcane. D) Mouse.
- Q.182 The cell suspension culture of _____ produces quinine.**
 A) Soybean. C) Digitalis lanata.
 B) Cinchona ledgeriana. D) Luceferin.

Q.183 Which one of the following is most slender in structure?

- A) Microtubules.
- B) Micro filaments.
- C) Intermediate filaments.
- D) Both A and B.

Q.184 Name the human tissues that contain about 85% water.

- A) Nerve cells.
- B) Bone cells.
- C) Brain cells.
- D) None of these.

Q.185 Which of the following are colorless?

- A) Chloroplasts.
- B) Chromoplasts.
- C) Leucoplasts.
- D) None of these.

Q.186 Name the one involved in DNA replication.

- A) Cysts.
- B) Mesosomes.
- C) Ribosomes.
- D) Spores.

Q.187 Which of the following has rootless sporophytes?

- A) Psilopsida.
- B) Tracheophyta.
- C) Lycopsida.
- D) Sphenopsida.

Q.188 Chlorophylls absorb mainly _____ wave length.

- A) Yellow.
- B) Green.
- C) Violet-blue.
- D) Indigo.

Q.189 _____ did not have the adaptations to remove the flooding of their cells in fresh water.

- A) Both B, D.
- B) Hydrophytes.
- C) None of B, D.
- D) Xerophytes.

Q.190 Which of the following is made up of bones and cartilage?

- A) Endoskeleton.
- B) Exoskeleton.
- C) Hydrostatic skeleton.
- D) Both A and B.

Q.191 This disease is characterized by the decline in brain function.

- A) Alzheimer's disease.
- B) Parkinson's disease.
- C) Epilepsy.
- D) None of these.

Q.192 Prophase, metaphase and telophase are subdivisions of

- A) Mitosis.
- B) Karyokinesis.
- C) Cytokinesis.
- D) None of these.

Q.193 _____ organs are functionally different but structurally alike.

- A) Analogous.
- B) Unillogous.
- C) Homologous.
- D) Hypologous.

Q.194 Which of the following gives blue color with iodine?

- A) Starch.
- B) Cellulose.
- C) Glycogen.
- D) All of these.

Q.195 Herpes simplex is caused by _____ virus.

- A) Enveloped RNA.
- B) RNA tumor.
- C) Glycogen.
- D) Both B and C.

Q.196 Name the cyanobacteria which are helpful in fixing atmospheric nitrogen.

- A) Heterocysts.
- B) Nostoc.
- C) Akinetes.
- D) Hormogonia.

Q.197 Name the class that contains seedless plants.

- A) Angiospermae.
- B) Gemnospermae.
- C) Paraphsys.
- D) Filicineae.

Q.198 Which form of anaerobic respiration occurs in muscle cell of humans and other animals during extreme physical activities?

- A) Alcoholic fermentation.
- B) Lactic acid fermentation.
- C) Glycolysis.
- D) Pyruvic acid oxidation.

- Q.199 How much water approximately is required to excrete 1 kg of ammonia nitrogen?**
 A) 500 ml. C) 300 litre.
 B) 5 litre. D) 500 litre.
- Q.200 Which disease causes immobility and fusion of vertebral joint?**
 A) Sciatica. C) Disc slip.
 B) Spondylosis. D) Rickets.
- Q.201 Which hormone continues to promote protein synthesis throughout the body even after the cease in growth?**
 A) TSH. C) ACTH.
 B) ADH. D) STH.
- Q.202 Position of a gene on the chromosome is called its**
 A) Phenotype. C) Junction.
 B) Locus. D) Genotype.
- Q.203 Pick the biotic component from the following.**
 A) Soil. C) Atmosphere.
 B) Water. D) Animals.
- Q.204 The two strands in DNA are coiled _____ to each other.**
 A) Parallel. C) Both A, B.
 B) Antiparallel. D) None of these.
- Q.205 Name the class without antennae.**
 A) Arachnida. C) Insecta.
 B) Myriapoda. D) Crustacea.
- Q.206 The African sleeping sickness is caused by _____**
 A) Entamoeba histolytica. C) Zooflagellates.
 B) Trypanosoma. D) Ciliates.
- Q.207 Which of the following does not belong to angiospermic families?**
 A) Picea. C) Rosaceae.
 B) Poaceae. D) Fabaceae.
- Q.208 Name the nutrition resulted by feeding on dead and decaying matter.**
 A) Saprophytic. C) Symbiotic.
 B) Parasitic. D) Both B and C.
- Q.209 How many grams of nitrogen can be eliminated in form of uric acid by 50 ml of water?**
 A) 20. C) 30.
 B) 25. D) 50.
- Q.210 Which disease is caused by low calcium in the blood?**
 A) Tetany. C) Muscle fatigue.
 B) Cramp. D) Sciatica.
- Q.211 It is known that red light _____ flowering in the long day plants.**
 A) Synchronizes. C) Promotes.
 B) Inhibits. D) Does not affect.
- Q.212 The colour phenotype of the grain is the sum of individual effects of _____ alleles.**
 A) Six. C) Four.
 B) Five. D) Five or three.
- Q.213 In _____ zone the light is insufficient to support photosynthesis.**
 A) Desert. C) Littoral.
 B) Profundal. D) All of these.

- Q.214 The optimum temperature for enzymes of human body is**
A) 32 °F. C) 313 K.
B) 46 °C. D) 37 °C.
- Q.215 Which of the following damages wooden ships?**
A) Sepia. C) Teredo.
B) Limax. D) Ostrea.
- Q.216 Which of the following may build coral reefs along with coral animals?**
A) Myxomycota. C) Green algae.
B) Brown algae. D) Red algae.
- Q.217 Which of the following do not have a body cavity?**
A) Pseudocoelomata. C) Coelomata.
B) Acoelomata. D) None of these.
- Q.218 Name the neurotic disorder characterized by bouts of over eating of fattening foods.**
A) Bulimia nervosa. C) Anorexia nervosa.
B) Dyspepsia. D) Salmonella.
- Q.219 Which one of these is an example of tubular excretory system called metanephridia?**
A) Planaria. C) Cockroach.
B) Hydra. D) Earthworm.
- Q.220 Name the human tissues that contain about 85% water**
A) Nerve cells. C) Brain cells.
B) Bone cells. D) None of these.
-

ALL TOPPER RECOMMEND UNIT WISE MDCAT PAST PAPERS BOOK 2008-2019

THIS BOOK ONLY AVAILABLE ONLINE ON MBBS.COM.Pk

MBBS.COM.PK

UHS MDCAT PAST PAPERS
BOOK Hard Copy Available
Now.

MBBS.COM.PK
EDUCATION SYSTEM

MDCAT GUIDE
UHS ENTRY TEST

MDCAT

PAST PAPER 2008-2019

- UNIT-WISE SOLVED MCQ's
- HIGHLIGHT REPEATED MCQ's
- CHANGING THE WAY YOU THINK
- BEST SOURCE TO GET HIGH MARKS
- UPDATED EDITION 2020
- AS PER UHS SYLLABUS

START
ENTRY TEST
PREPARATION
2020

LIVE CHAT
0304-7418334

Rs. 1400/=

Free Home Delivery

TO Book Order For MDCAT Past Papers
Call Or WhatsApp **0304-7418334**

University of Health Sciences, Lahore



Total MCQs: 220

Max. Marks: 1100

ENTRANCE TEST - 2010

For F.Sc. Students Only

Time Allowed: 150 minutes

Instructions:

- Read the instructions on the MCQs Response Form carefully.
- Choose the **Single Best Answer** for each question.
- Candidates are strictly prohibited from giving any identification mark except Roll No. & Signature in the specified columns only.

COMPULSORY QUESTION FOR IDENTIFICATION

Q-ID. What is the color of your Question Paper?

A) White.

C) Pink.

B)

Blue.

D) Green.

ID

**Ans: Colour of your Question Paper is Pink.
Fill the Circle Corresponding to Letter 'C'
against 'ID' in your MCQ response form
(Exactly as shown in the diagram).**

	A	B	C	D
1	<input type="radio"/>	<input type="radio"/>	<input checked="" type="radio"/>	<input type="radio"/>
2	<input type="radio"/>	<input type="radio"/>	<input type="radio"/>	<input type="radio"/>
3	<input type="radio"/>	<input type="radio"/>	<input type="radio"/>	<input type="radio"/>
4	<input type="radio"/>	<input type="radio"/>	<input type="radio"/>	<input type="radio"/>

PHYSICS

Q.1 Which one is the highest power multiple?

- A) Giga
B) Tera

- C) Mega
D) Deca

Q.2 SI unit of charge is _____

- A) Ampere
B) Volt

- C) Coulomb
D) Calorie

Q.3 The electrical analog of mass is electricity is _____

- B) Inductance

- A) Capacitance C) Charge
D) Resistance

Q.4 Which one of the following relations is correct?

- A) $1 \text{ wb m}^{-2} = \text{N m}^{-1} \text{ A}^{-1}$
B) $1 \text{ Tesla} = 10^4 \text{ Gauss}$

- C) $1 \text{ wb m}^{-2} = 1 \text{ Tesla}$
D) All of these

Q.5 Life time of electron in metastable state is about _____

- A) 10^{-5} sec
B) 10^{-3} sec

- C) 10^{-8} sec
D) 10^{-2} sec

Q.6 The torque acting on a current carrying coil is given by _____

- A) $\tau = NIAB \cos \alpha$
B) $\tau = BIL \sin \alpha$

- C) $\tau = NIAB \sin \alpha$
D) $\tau = BIL \cos \alpha$

Q.7 The grid in the cathode ray oscilloscope _____

- A) Controls number of waves
B) Controls the brightness of spot formed

- C) Accelerates electrons
D) Has positive potential with respect to cathode

- Q.8 The horizontal range of a projectile, at a certain place, is completely determined by**
 A) The angle of projection
 B) The initial velocity of projection
 C) The mass of the projectile
 D) Speed and mass of the projectile
- Q.9 If velocity is double, then.**
 A) Momentum increase 4 times and K.E increases 2 times
 B) Momentum and K.E remain same
 C) Momentum increases 2 times and K.E increase constant
 D) Momentum increases 2 times and K.E increases 4 times
- Q.10 The consumption of energy by 60-watt bulb in 2 seconds is:**
 A) 20 J
 B) 120 J
 C) 30 J
 D) 0.02 J
- Q.11 In transistors, the base region is very thin, of the order of**
 A) 10^{-5} cm
 B) 10^{-6} m
 C) 10^{-6} mm
 D) 10^{-6} μ m
- Q.12 The closed loop gain of OP-AMP depends on**
 A) Internal structure of OP-AMP
 B) Externally connected resistances
 C) Voltage of power supplies
 D) Input resistance
- Q.13 The net charge on an N-type substance is**
 A) 0.7 volts
 B) 0.3 volts
 C) 0.25 volts
 D) 0.07 volts
- Q.14 The value of Wien's constant is**
 A) 2.90×10^{-3} mK
 B) 3.34×10^{-4} mK
 C) 4.22×10^{-7} mK
 D) 3.42×10^{-8} mK
- Q.15 The minimum frequency below which no electron is emitted from the metal surface is called**
 A) High frequency
 B) Low frequency
 C) Threshold frequency
 D) Resonance frequency
- Q.16 In pair production, the type of photon used**
 A) α -particle
 B) β -particle
 C) X-rays
 D) γ -radiations
- Q.17 The life time of an electron in an excited state is about 10^{-8} s. What is its uncertainty in energy during this time?**
 A) 1.05×10^{-41} J
 B) 1.05×10^{-26} J
 C) 1.15×10^{10} J
 D) 2.19×10^{-40} J
- Q.18 Velocity of electron moving in first orbit of hydrogen is**
 A) 2.19×10^7 m/sec
 B) 2.18×10^7 m/sec
 C) 2.2×10^8 m/sec
 D) 2.19×10^6 m/sec
- Q.19 LASER is a potential energy source for inducing which type of reaction?**
 A) Radioactive
 B) Fission
 C) Ionization
 D) Fusion
- Q.20 In the half-life of an element, the equation for the number of decaying atoms is given by**
 A) $\Delta N \propto -N\Delta t$
 B) $\Delta N = KN\Delta t$
 C) $\Delta N \propto -n\Delta t$
 D) $\Delta N = -\Delta N\Delta t$
- Q.21 Decay constant ' λ ' is given as**
 A) $-\frac{\Delta N/N}{\Delta t}$
 B) $-\frac{\Delta N}{\Delta t}$
 C) $-\frac{N}{\Delta t}$
 D) $\frac{\Delta N/N}{\Delta t}$

- Q.22 The SI unit of absorbed dose 'D' i.e. radiation effect is Gray and one Gray is equal to**
 A) kJ / mol
 B) J / mol
 C) kg / J
 D) J / kg
- Q.23 The principle of homogeneity of dimensions determines**
 A) Only variable in the equation
 B) Only constant in the equation
 C) Correctness of an equation
 D) Constant and variable in the equation
- Q.24 For a body to be in complete equilibrium**
 A) Linear acceleration is zero
 B) Angular acceleration is zero
 C) Linear acceleration is zero but angular acceleration is not zero
 D) Linear acceleration and angular acceleration both should be zero
- Q.25 If length of a spanner is 'l' and a force 'F' is applied on it to tighten a nut such that it passes through the pivot point, then torque is**
 A) Zero
 B) Fl
 C) Fl sin θ
 D) Fl sin $\theta\lambda$
- Q.26 If a force of magnitude 8 N acts on a body in direction making an angle 30, its x and y components will be**
 A) $F_x = 4\sqrt{3}$ and $F_y = 8$
 B) $F_x = 8$ and $F_y = 4\sqrt{3}$
 C) $F_x = 4\sqrt{3}$ and $F_y = 4$
 D) $F_x = 8\sqrt{3}$ and $F_y = 4$
- Q.27 The difference of a vector \vec{B} and its negative vector $-\vec{B}$ is**
 A) A null vector
 B) Equal to magnitude of vector \vec{B}
 C) Twice the magnitude of vector \vec{B}
 D) Smaller than magnitude of vector \vec{B}
- Q.28 Time of projectile's flight is**
 A) $\frac{v_i \sin^2 \theta}{g}$
 B) $\frac{2v_i \sin \theta}{g}$
 C) $\frac{v_i^2 \sin^2 \theta}{g}$
 D) $\frac{v_i}{g} \sin 2\theta$
- Q.29 If the velocity of the body changes by equal amount in equal intervals of time, the body is said to have:**
 A) variable acceleration
 B) uniform acceleration
 C) uniform velocity
 D) negative acceleration
- Q.30 In order to determine the maximum height of the projectile, the equation of motion used is**
 A) $aS = v_f^2 - v_i^2$
 B) $2aS = v_f^2 - v_i^2$
 C) $2S = a(v_f^2 - v_i^2)$
 D) $aS = 2(v_f^2 - v_i^2)$
- Q.31 If a force of 12 N acts on a car and changes its momentum from 36 kgm/sec to 60 kgm/sec, the time during which this change occurs will be**
 A) 24 sec
 B) 2 sec
 C) 12 sec
 D) 8 sec
- Q.32 Which one of the following is a non-conservative force?**
 A) Electric force
 B) Elastic spring force
 C) Gravitational force
 D) Frictional force
- Q.33 Value of escape velocity for the surface of the earth is 11 km/sec. Its value for surface of the moon is**
 A) 11 km/sec
 B) 10.4 km/sec
 C) 2.4 km/sec
 D) 4.3 km/sec
- Q.34 On a clear day at noon, the intensity of solar energy reaching the earth's surface is about**
 A) 1.0 kWm⁻²
 B) 1.4 kWm⁻²
 C) 1.0 Wm⁻²
 D) 1.4 Wm⁻²

- Q.35 When a lift is accelerated upward, the apparent weight of an object in it will be**
 A) Equal to its real weight
 B) Less than its real weight
 C) Zero
 D) Greater than its real weight
- Q.36 The moment of inertial of a thin rod is**
 A) $\frac{1}{2} mL_2$
 B) $\frac{1}{4} mL_3$
 C) $\frac{1}{12} mL$
 D) $\frac{1}{12} mL_2$
- Q.37 A wheel of radius 1 m covers an angular displacement of 180. Its linear displacement is**
 A) 3.14 m
 B) π rad
 C) 6.28 m
 D) 0.157 m
- Q.38 Conservation of mass of fluid flow leads to**
 A) Bernoulli's equation
 B) Venturi meter
 C) Equation of motion
 D) Equation of continuity
- Q.39 The blood vessels collapse when**
 A) External pressure applied becomes greater than the systolic pressure
 B) External pressure applied is equal to systolic pressure
 C) External pressure applied is less than the systolic pressure
 D) External pressure applied is zero
- Q.40 An oscillating body is at mean position at $t = 0$. At $t = T/4$ it will be at**
 A) Extreme position
 B) Mean position
 C) Between extreme and mean position
 D) Beyond extreme position
- Q.41 In a simple pendulum, the tension of the string is**
 A) $g \cos \theta$
 B) $mg \sin \theta$
 C) $mg \cos \theta$
 D) mg
- Q.42 Two sound waves having the same amplitudes are moving in the same direction are out of phase. The amplitude of the resultant wave is**
 A) Zero amplitude
 B) The sum of amplitude of the two waves
 C) Difference of the amplitudes of the two waves
 D) Double the amplitude of either wave
- Q.43 A source 'Y' of unknown frequency produces 4 beats with a source of 240 Hz and 8 beats with a sound of 252 Hz. Frequency of the source 'Y' is**
 A) 244 Hz
 B) 236 Hz
 C) 248 Hz
 D) 246 Hz
- Q.44 An organ pipe closed at one end has a length of 25 cm. Wavelength of the fundamental note is**
 A) 25 cm
 B) 50 cm
 C) 100 cm
 D) 75 cm
- Q.45 In Newton ring apparatus, at the point of contact of the lens and glass plate, the additional path difference introduced is**
 A) $\lambda/4$
 B) $\lambda/2$
 C) λ
 D) $\lambda/3$
- Q.46 The path difference 'BD' for destructive interference is**
 A) $(m + 1/2) \lambda$
 B) $m\lambda$
 C) $d \sin \theta$
 D) 3λ
- Q.47 In the case of a grating spectrometer, the resolving power 'R' of the grating is defined as**
 A) $\lambda / \Delta\lambda$
 B) λ / D
 C) λ / λ_1
 D) $N \times m$
- Q.48 Which one of the following lights travels fastest in optical fibers?**
 A) Visible light
 B) Ultraviolet light
 C) Ordinary light
 D) Invisible infrared light

- Q.49 The value of universal gas constant is**
 A) $8.314 \text{ Jmol}^{-1}\text{K}^{-1}$ C) $7.23 \text{ Jmol}^{-1}\text{K}^{-1}$
 B) $8.324 \text{ Jmol}^{-1}\text{K}^{-1}$ D) $1.00 \text{ Jmol}^{-1}\text{K}^{-1}$
- Q.50 The turbine in a steam power plant takes steam from a boiler at 427°C and exhausts into a low temperature reservoir at 77°C . What is the maximum possible efficiency?**
 A) 50% C) 60%
 B) 40% D) 70%
- Q.51 Which one of the following is a postulate of kinetic theory of gases?**
 A) Molecules do not exert force on each other
 B) The size of molecules is much larger than separation between the molecules
 C) A finite volume of gas consists of a very small number of molecules
 D) The gas molecules are not in random motion
- Q.52 Which one is not an irreversible process?**
 A) Slow compression of a gas into a cylinder C) Explosion
 B) Changes due to friction D) Dissipation of energy
- Q.53 Electric intensity is a vector quantity and its direction is**
 A) Perpendicular to the direction of field C) At a certain angle
 B) Opposite to the direction of force D) Along the direction of force
- Q.54 The magnitude of an electric field between two separated plates can be calculated by the relation**
 A) $\Delta V = Ed$ C) $\Delta V = \frac{E}{d}$
 B) $\Delta V = E/d$ D) $E = \frac{d}{\Delta V}$
- Q.55 SI unit of electric flux is**
 A) NmC^{-1} C) Nm^2C^{-2}
 B) $\text{Nm}^{-2}\text{C}^{-2}$ D) Nm^2C^{-2}
- Q.56 The equivalent current which passes from a point at higher potential to a point at a lower potential as if it represented a movement of positive charges is**
 A) Electronic current C) Magnetic lines
 B) Electric current D) Conventional current
- Q.57 If 'V' is applied potential difference across a resistance 'R', then loss in potential energy per unit time is**
 A) VI C) $\frac{V^2}{R}$
 B) I^2R D) All of the above
- Q.58 The substances like germanium and silicon have**
 A) Negative temperature coefficients C) Both A and B
 B) Positive temperature coefficients D) None of the above
- Q.59 The sensitivity of a galvanometer can be decreased by**
 A) Increasing magnetic field C) Increasing $\frac{c}{\text{BAN}}$ Ration
 B) Increasing number of turns of the coil D) Decreasing length of couple 'c'
- Q.60 Force on a current carrying conductor in a uniform magnetic field is**
 A) $F = NIA \cos \alpha$ C) $F = ILB \sin \alpha$
 B) $F = \mu nI$ D) $F = ILA \cos \alpha$

CHEMISTRY

- Q.61 In an electrochemical series, standard electrode potentials are arranged on the basis of:**
 A) pH scale C) Hydrogen Scale
 B) pOH scale D) pK_a scale

Q.62 The reaction which is responsible for the production of electricity in the Voltaic cell is:

- A) Hydrolysis reaction
- B) Oxidation reaction
- C) Redox reaction
- D) Reduction reaction

Q.63 Glucose is converted into ethanol by the enzyme _____ present in yeast:

- A) Urease
- B) Invertase
- C) Sucrase
- D) Zymase

Q.64 The rate of reaction involving ions can be studied by _____ method

- A) Dilatometric
- B) Refractometric
- C) Optical rotation
- D) Electrical conductivity

Q.65 When one mole of gaseous hydrogen ions are dissolved in water to form an infinitely dilute solution, the amount of heat liberated is

- A) -1891 kJmol^{-1}
- B) -1075 kJmol^{-1}
- C) -499 kJmol^{-1}
- D) -1562 kJmol^{-1}

Q.66 Energy required to remove an electron from the outermost shell of its isolated gaseous atom in the ground state is

- A) Electron affinity
- B) Lattice energy
- C) Ionization energy
- D) Crystal energy

Q.67 Which of the following carbonates of alkali metals is not stable towards heat and is decomposed on heating to its oxide along with liberation of CO_2 ?

- A) Li_2CO_3
- B) Mg_2CO_3
- C) K_2CO_3
- D) Na_2CO_3

Q.68 The presence of calcium is essential for the normal development of plants. An adequate supply of calcium appears to stimulate the development of which part of the plants?

- A) Leaves
- B) Fruits
- C) Root hairs
- D) Branches

Q.69 Which of the following sulphates is not soluble in water?

- A) Sodium Sulphate
- B) Barium Sulphate
- C) Potassium Sulphate
- D) Zinc Sulphate

Q.70 The trend in the densities of elements of Group III-A of the Periodic Table is

- A) A gradual increase
- B) A gradual decrease
- C) First decrease then increase
- D) First increase then decrease

Q.71 White lead has one of the following properties

- A) Acidic
- B) Crystalline
- C) Amorphous
- D) Neutral

Q.72 The strongest acid among the following is

- A) HF
- B) HI
- C) HCl
- D) HBr

Q.73 The noble gas which is used in radiotherapy of cancer is

- A) Radon
- B) Xenon
- C) Krypton
- D) Argon

Q.74 Paramagnetic behavior of an atom, ion or molecule is due to presence of

- A) Unpaired electrons
- B) Paired electrons
- C) Protons
- D) Neutrons

Q.75 The geometry of the complexes depends upon the type of _____ taking place in the valence shell of the central metal atom

- A) Hybridization
- B) Protonation
- C) Deprotonation
- D) Dissociation

Q.76 KMnO_4 acts as a

- A) Reducing agent
- B) Excellent precipitating reagent
- C) Germicide
- D) Oxidizing agent

- Q.77 A gasoline of higher octane number can be obtained by**
 A) Oxidative cleavage
 B) Thermal cracking
 C) Catalytic cracking
 D) Steam cracking
- Q.78 Ethyne molecule is formed when two carbon atoms joined together to form a sigma bond by**
 A) sp-s overlap
 B) sp³-sp³ overlap
 C) 2p_y-2p_y overlap
 D) sp-sp overlap
- Q.79 Symmetrical alkanes can be produced by**
 A) Sabatier Sender's Reaction
 B) Hydrogenolysis Reaction
 C) Reduction Reaction
 D) Kolbe's Electrolytic Reaction
- Q.80 The catalyst used for the preparation of acrylonitrile is**
 A) Cu₂Cl₂ and NH₄Cl
 B) Al₂O₃ and NH₄Cl
 C) Cu₂Cl₂ and NH₄OH
 D) Cu₂Cl₂ and Al₂O₃
- Q.81 When a hydrogen atom is removed from benzene, the group left behind is called**
 A) Alkyl group
 B) Phenyl group
 C) Benzyl group
 D) Methyl group
- Q.82 The introduction of NO₂ group in benzene ring is called 'Nitration'. The nitration of benzene takes place when it is heated with a 1:1 mixture of _____ at 50 °C-55 °C.**
 A) Conc. HNO₃ and conc. HCl
 B) Conc. HNO₃ and conc. Acetic acid
 C) Conc. HNO₃ and H₃PO₄
 D) Conc. HNO₃ and conc. H₂SO₄
- Q.83 During S_N2 reactions, configuration of the alkyl halide molecule:**
 A) Gets inverted
 B) Remains same
 C) Depends upon the carbon atom
 D) Depends upon the electronegativity of halide
- Q.84 Grignard reagents are prepared by the reaction of magnesium metal with alkyl halides in the presence of**
 A) Dry Ether
 B) Sodium Lead Alloy
 C) Alcohol
 D) Water
- Q.85 Methanol is prepared from carbon monoxide and hydrogen. The catalyst used for this reaction is**
 A) ZnO + CoO₂
 B) ZnO + CuO
 C) ZnO + Ag₂O
 D) Cr₂O₃ + ZnO
- Q.86 Ethanol reacts with Ammonia to produce ethyl amine, the catalyst is**
 A) ZnCl₂
 B) ThO₂
 C) C₆H₅N
 D) Cr₂O₃
- Q.87 Dissociation constant of phenol is**
 A) 1.2 × 10⁻¹⁰
 B) 1.2 × 10¹⁰
 C) 1.3 × 10¹⁰
 D) 1.3 × 10⁻¹⁰
- Q.88 Dry distillation of a mixture of calcium salts of formic acid and acetic acid results into the formation of**
 A) Formaldehyde
 B) Acetaldehyde
 C) Calcium acetate
 D) Sodium acetate
- Q.89 Hydrolysis of cyano group by an aqueous acid results into**
 A) Carboxylic Acid
 B) Acid Amide
 C) Cyanohydrate
 D) Formaldehyde
- Q.90 Brick red precipitates are formed when aldehydes react with**
 A) Sodium borohydride
 B) Sodium bisulphite
 C) Sodium nitroprusside
 D) Fehling's solution
- Q.91 The nature of the amino acid 'lysine' is**
 A) Neutral
 B) Acidic
 C) Amphoteric
 D) Basic

Q.92 Which of the following compounds, in the form of aqueous solution, on reaction with sodium carbonate will produce carbon dioxide gas?

- A) $\text{H}_3\text{C}-\text{COO}-\text{C}_2\text{H}_5$ C) $\text{H}_3\text{C}_2-\text{CO}-\text{OH}$
 B) $\text{H}_3\text{C}_2-\text{COO}-\text{CH}_3$ D) $\text{H}_3\text{C}_2-\text{COO}-\text{C}_2\text{H}_5$

Q.93 Collagen and albumin are

- A) Simple proteins C) Polyamides
 B) Derived proteins D) Polysaccharides

Q.94 Urea is produced by the reaction of liquid ammonia with

- A) CO_2 C) CaO
 B) CO D) C

Q.95 The calcium sulpho-aluminate is

- A) $\text{Ca} \cdot \text{Al}_2\text{O}_3 \cdot 3\text{CaSO}_4 \cdot 6\text{H}_2\text{O}$ C) $3\text{Ca} \cdot \text{Al}_2\text{O}_3 \cdot 3\text{CaSO}_4 \cdot 2\text{H}_2\text{O}$
 B) $3\text{Ca} \cdot \text{Al}_2\text{O}_3 \cdot \text{CaSO}_4 \cdot 2\text{H}_2\text{O}$ D) $3\text{Ca} \cdot \text{Al}_2\text{O}_3 \cdot 3\text{CaSO}_4 \cdot 6\text{H}_2\text{O}$

Q.96 The coagulant used in raw water to precipitate suspended impurities is

- A) Caustic soda C) Alum
 B) Lime water D) Soda ash

Q.97 The whiteness of the recycled newspaper is improved by treating it with:

- A) Sodium hydroxide C) Super oxides
 B) Peroxides D) Normal oxides

Q.98 One mole of any gas at standard temperature and pressure (STP) occupies a volume of

- A) 20.414 dm^3 C) 22.414 cm^3
 B) 22.414 dm^3 D) 23.414 dm^3

Q.99 The relative abundance of the isotopes of the elements can be determined by:

- A) Mass Spectrometry C) Chromatography
 B) X-rays D) Solvent Extraction

Q.100 If we are given the mass of one substance, we can calculate volume of other substances and vice versa with the help of balanced chemical equation. This is called

- A) Mass-mass relationship C) Mole-volume relationship
 B) Mass-mole relationship D) Mass-volume relationship

Q.101 Sublimation is used to purify

- A) Ammonium sulphate C) Benzoic acid
 B) Sodium chloride D) Lead carbonate

Q.102 The purity of a substance can be identified by

- A) Sublimation C) Chromatography
 B) Filtration D) Solvent extraction

Q.103 Which one of the following mathematical expressions represents the Avogadro's law?

- A) $V = R \frac{nT}{p}$ (when 'T' and 'n' are constant) C) $V = R \frac{p}{nT}$ (when 'P' and 'n' are constant)
 B) $V = R \frac{p}{T}$ (when 'P', 'T' and 'n' are constant) D) $V = R \frac{nT}{P}$ (when 'P' and 'T' are constant)

Q.104 The root mean square velocity of gases is inversely proportional to the square root of their:

- A) Molar mass C) Pressure
 B) Temperature D) Volume

Q.105 Plasma is the ionized gas mixture which consists of

- A) Ions and electrons C) Electrons, ions and neutral atoms
 B) Electrons and neutral atoms D) Ions and neutral atoms

Q.106 Which type of force is present in gasoline?

- A) Dipole-dipole forces C) London dispersion forces
 B) Dipole-induced dipole forces D) hydrogen bonding

- Q.107** In the structure of NaCl, each Na⁺ is surrounded by _____ Cl⁻ ions.
 A) Four
 B) Eight
 C) Five
 D) Six
- Q.108** The charge of one gram of electron is
 A) 1.7588×10^{-11}
 B) 1.7588×10^{11}
 C) 1.602×10^{-19}
 D) 1.7588×10^8
- Q.109** The ionization energy of hydrogen atom is
 A) Zero
 B) 13.13 kJmol⁻¹
 C) 1313.31 kJmol⁻¹
 D) 1313.31 k²Jmol
- Q.110** Which quantum number helps to study the orientation of an orbital in space?
 A) Principal Quantum Number
 B) Spin Quantum Number
 C) Magnetic Quantum Number
 D) Azimuthal Quantum Number
- Q.111** The inter-ionic distance in a crystal lattice of KCl is
 A) 314 pm
 B) 181 pm
 C) 95 pm
 D) 300 pm
- Q.112** The number of bonds in nitrogen molecule is
 A) One σ and two π
 B) One σ and one π
 C) Three σ only
 D) Two σ and one π
- Q.113** Which one of the following molecules has zero dipole moment?
 A) NH₃
 B) CHCl₃
 C) BF₃
 D) H₂O
- Q.114** A spontaneous process is
 A) Unidirectional and irreversible
 B) Irreversible and a real process
 C) Unidirectional and a real process
 D) All of the above
- Q.115** The standard enthalpy of solution of NH₄Cl is _____ kJmol⁻¹.
 A) +16.2
 B) -25.0
 C) +4.98
 D) +26.0
- Q.116** The K_c has following units for the reaction $\text{H}_{2(g)} + \text{I}_{2(g)} \rightleftharpoons 2\text{HI}_{(g)}$
 A) mol³dm⁻⁶
 B) moldm⁻³
 C) mol⁻³dm⁶
 D) No unit
- Q.117** 0.1 mole of acetic acid has been dissolved per dm³ of the solution, the percentage ionization of acetic acid will be
 A) 13
 B) 15
 C) 1.3
 D) 0.1
- Q.118** Solubility of Ce₂(SO₄)₃
 A) Increases with temperature
 B) Decreases with temperature
 C) Shows exceptional behavior
 D) Remains constant
- Q.119** Seawater has 5.65×10^{-3} g of dissolved oxygen in one kilogram of water. Concentration of O₂ in parts per million is
 A) 5.65
 B) 7.69
 C) 5.20
 D) 4.11
- Q.120** Metallic conduction involves the relatively free movement of their _____ throughout the metallic lattice
 A) Atoms
 B) Molecules
 C) Electrons
 D) Ions

ENGLISH

- Q.121** My advice had no _____ on him.
 A) Effect
 B) Affect
 C) Influence
 D) Impression

Q.122 Do not lose heart, it is just a _____ in the tea cup

- A) Wind
- B) Cyclone
- C) Blast
- D) Storm

Q.123 Pakistan _____ from voting against Iran in the United Nations

- A) Prevented
- B) Detained
- C) Abstained
- D) Refused

Q.124 Please _____ the door after you.

- A) Close
- B) Shut
- C) Leave
- D) Knock



SPOT THE ERROR: In the following sentences, some segments of each sentence are underlined. Your task is to identify that underlined segment of the sentence, which contains the mistake that needs to be corrected. Fill the Circle corresponding to that letter under the segment in the MCQ Response Form.

Q.125 Suddenly he stopped at the edge of the meadow, taking his pocket knife from his pocket, and cut a wisp of alfalfa.

- A) Suddenly he stopped
- B) taking his pocket knife from his pocket
- C) and cut
- D) a wisp of alfalfa.

Q.126 The study of population growth indicates one of the greatest paradox of our time.

- A) The study of population growth
- B) indicates
- C) one of the greatest
- D) paradox

Q.127 Among the Western nations, the decline in the death rate is followed after an interval by the reduction in the birth rate, so that the population is not now growing so fast.

- A) Among the Western nations
- B) the decline in the death rate is followed
- C) after an interval by the
- D) reduction in the birth rate

Q.128 In view of increasing hazards with our national security it is the duty of every citizen to keep a watch on his surroundings.

- A) with
- B) it is
- C) to keep
- D) watch on his surroundings.

Q.129 Thrifty housewives preserved their homegrown vegetables and fruits in canning, pickling or drying them for use during the cold weather.

- A) in
- B) pickling
- C) or
- D) drying

Q.130 When a low-wage category worker finds he has to maintain a large family, his expenses may exceeds his income.

- A) When a low-wage category worker finds
- B) he has to maintain a large family
- C) his expenses may
- D) exceeds his income.



In each of the following question, four alternative sentences are given. Choose the CORRECT one and fill the Circle corresponding to that letter in the MCQ Response Form.

Q.131

- A) This is different to what had been expected.
- B) This is different what had been expected.
- C) This is different from what had been expected.
- D) This is different to what would be expected.

Q.132

- A) He suddenly remembered that he has left his house unlocked.
- B) He suddenly remembered that he may have left his house unlocked.
- C) He suddenly remembered that he had left his house unlocked.
- D) He suddenly remembered that he will have left his house unlocked.

Q.133

- A) He asked us would we care to go.
- B) He asked us if we would care to go.
- C) He asked us we would care to go.
- D) He asked us we will care to go.

Q.134

- A) When this war is over, no nation will either be isolated in war or peace.
 B) When this war is over, no nation will be either isolated in war or peace.
 C) When this war is over, no nation will neither be isolated in war nor peace.
 D) When this war is over, no nation will be isolated either in war or in peace.

Q.135

- A) When the fact failed him, he questions his senses.
 B) When the fact failed him, he questioned from his senses.
 C) When the fact fails him, he questions his senses.
 D) He will question his senses, when the fact will fail him.

Q.136

- A) He said there has been no need to do it.
 B) He said there wasn't no need to do it.
 C) He said there had been not any need doing it.
 D) He said there was no need to do it.

Q.137

- A) I could barely make of the traffic signs through the rain.
 B) I could barely make out the traffic signs because of the rain.
 C) I could barely make up the traffic signs through the rain.
 D) I could barely make with the traffic signs through the rain.

Q.138

- A) He walked as though he is lame.
 B) He walked as though he was lame.
 C) He walked as though he were lame.
 D) He walked as though he may have been lame.

Q.139

- A) E-mail is a relatively new means of communication.
 B) E-mail is a relatively new mean of communication.
 C) E-mail is a relatively new mean to communication.
 D) E-mail is a relatively new means to communication.

Q.140

- A) The remain of the body was thrown into the sea.
 B) The remains of the body were thrown into the sea.
 C) The remains of the body were thrown to the sea.
 D) The remains of the body was thrown into the sea.



In each of the following question, four alternative meanings of a word are given. You have to select the NEAREST CORRECT MEANING of the given word and fill the appropriate Circle on the MCQ Response Form.

Q.141

WALLOW

- A) Roll about
 B) Mock
 C) Protest
 D) Borrow

Q.142

CONNOISSEUR

- A) Guide
 B) Artist
 C) Expert critic of art
 D) Teacher

Q.143

ECCENTRIC

- A) Lunatic
 B) Stern
 C) Upset
 D) Odd

Q.144

BOULDER

- A) Rounded stone / hill
 B) Builder
 C) Magnanimity
 D) Magnitude

Q.145

SLUMBER

- A) Heap
 B) Humble
 C) Knee
 D) Sleep

Q.146

EXCREMENT

- A) Increment
 B) Waste matter expelled from body
 C) Excitement
 D) Disagreement

Q.147 VISAGE

- A) Vision
- B) Illusion
- C) Trunk less
- D) A person's face

Q.148 FELICITY

- A) Intense Happiness
- B) Respite
- C) Inspire
- D) Sensational

Q.149 ENMESHED

- A) Sojourn
- B) Entangled
- C) Gallows
- D) Cascade

Q.150 CAPTIVATE

- A) Hesitate
- B) Concentrate
- C) Hate
- D) Fascinate

BIOLOGY

Q.151 Book lungs are present in arthropods for exchange of gases in class:

- A) Crustacea
- B) Insecta
- C) Myriapoda
- D) Arachnida

Q.152 Larvae of which group are similar to chordates?

- A) Echinodermata
- B) Annelida
- C) Arthropoda
- D) Nematoda

Q.153 Type of respiration which involves step by step breakdown of carbon chain molecules in the cell is called:

- A) External respiration
- B) Cellular respiration
- C) Pulmonary respiration
- D) Cutaneous respiration

Q.154 Instrument which is used to measure relative abilities of different pigments to absorb different wavelengths of light is called:

- A) Spectrometer
- B) Photometer
- C) Barometer
- D) Spectrophotometer

Q.155 End products of yeast fermentation, bacterial fermentation and anaerobic respiration are

- A) Citric acid, lactic acid, carbon dioxide and water
- B) Ethyl alcohol, citric acid and carbon dioxide
- C) Ethyl alcohol, lactic acid, carbon dioxide and water
- D) Methanol, lactic acid and citric acid

Q.156 In human beings, what is the function of amylase in digestion?

- A) Digestion of triglycerides
- B) Digestion of lipids
- C) Digestion of all types of food
- D) Digestion of carbohydrates

Q.157 Where is the ileocolic sphincter located in your body?

- A) At the junction of esophagus and stomach
- B) At the junction of stomach and small intestine
- C) At the junction of ileum and large intestine
- D) At the junction of small intestine and large intestine

Q.158 The term which is employed to the loss of appetite due to fear of becoming obese is

- A) Obesity
- B) Anorexia nervosa
- C) Dyspepsia
- D) Bulimia nervosa

Q.159 Which one of the following acts as functional unit of lungs in man?

- A) Air sac
- B) Larynx
- C) Trachea
- D) Bronchioles

Q.160 Which one of following factors is directly proportional to oxygen carrying capacity of haemoglobin?

- A) Carbon dioxide
- B) Temperature
- C) pH
- D) Light

- Q.161 Expiration in human beings is carried out by**
 A) Contraction of lungs
 B) Contraction of intercostal membrane
 C) Relaxation of intercostal and diaphragm muscles
 D) Contraction of diaphragm muscles
- Q.162 Which one of the following is a precursor of steroid hormones?**
 A) Glycerol
 B) Sterol
 C) Amino acids
 D) Cholesterol
- Q.163 Granulocytes or white blood cells are produced in**
 A) Lymph nodes
 B) Red bone marrow
 C) Tonsils
 D) Spleen
- Q.164 Which one of the following statements best describes the function of sinoatrial node?**
 A) It sends out electrical impulses to atrial muscles causing both atria to contract.
 B) It consists of small number of diffusely oriented cardiac fibres
 C) It sends out electrical impulses to ventricular muscles causing both ventricles to contract
 D) It is present at upper end of left atrium.
- Q.165 The flow of lymph in lymphatic vessels is maintained by:**
 A) Heart, activity of smooth muscles and valves
 B) Activity of skeletal muscles, heart and breathing movements
 C) Breathing movements, activity of skeletal muscles and valves
 D) Exercise, breathing movements and heart
- Q.166 Metabolic waste from metabolism of nucleic acid is**
 A) Uric acid
 B) Creatine
 C) Urea
 D) Creatinine
- Q.167 The central metabolic station and clearing house of a body is**
 A) Liver
 B) Kidney
 C) Nephron
 D) Glomerulus
- Q.168 The muscles that control urine in bladder are known as**
 A) Striated muscles
 B) Smooth muscles
 C) Sphincter muscles
 D) Circular muscles
- Q.169 The living cells of cartilage are called**
 A) Chondrocytes
 B) Osteoblasts
 C) Osteocytes
 D) Osteoclasts
- Q.170 The disease which causes immobility and fusion of vertebral joints is**
 A) Osteomalacia (soft bones)
 B) Disc slip
 C) Arthritis
 D) Spondylosis
- Q.171 During muscle contraction**
 A) I-band shortens
 B) Myosin filaments shorten
 C) Actin filaments shorten
 D) Z-line disappears
- Q.172 Hormones are the organic compounds of varying structural complexity. Which of the following is not a function or property of these compounds?**
 A) They initiate new biochemical reactions
 B) They are poured directly into blood
 C) They may be proteins
 D) They affect target cells
- Q.173 Reflexes and instincts type of behaviours respond to which combination /s?**
 A) Biological rhythms, territorial, courtship and development
 B) The responses that do produce same result in different conditions
 C) Aggression, mating and altruism
 D) The responses that are predetermined like differentiation.
- Q.174 A typical neuron at rest**
 A) Is more positive outside than inside
 B) Is more negative outside than inside
 C) Has no charge on either side
 D) Has an equal charge on either side

- Q.175 The first cells produced by the repeated cell division of germinal epithelium of testis are**
A) Interstitial cells
B) Spermatogonia
C) Secondary spermatocytes
D) Spermatids
- Q.176 Which of the following sequence is correct?**
A) LH FSH Estrogen Progesterone
B) FSH LH Progesterone Estrogen
C) FSH Estrogen Progesterone LH
D) FSH Estrogen LH Progesterone
- Q.177 Which chromosomal abnormality in humans causes aggressive and antisocial behavior?**
A) XO
B) XXY
C) XYY
D) XXX
- Q.178 Grey equatorial cytoplasm produces**
A) Muscle cells
B) Gut
C) Notochord and neural tube
D) Larval epidermis
- Q.179 Sickle cell Anaemia is an example of which type of chromosomal defect?**
A) Chromosomal rearrangement
B) Transposition of gene
C) Chromosomal aberration
D) Point mutation
- Q.180 The karyotype of an individual is _____ of chromosomes.**
A) Number
B) Types
C) Number, types and chemical composition
D) Number and types
- Q.181 The process of replication of DNA begins at**
A) One place only without any specific sequence of DNA
B) One or more places without any specific sequence of DNA
C) Any place with the uncoiling of two strands of DNA
D) One or more places where there is a specific sequence of nucleotides
- Q.182 Amino acid attaches at which site of RNA**
A) Anticodon site
B) Ribosomes recognition site
C) 3'-site with terminal OH
D) Activation enzyme recognition site
- Q.183 Microtubules of spindle fibres are composed of a protein called**
A) Tubulin
B) Actin
C) Myosin
D) Troponin
- Q.184 The kinetochore fibres contract and spindle or pole fibres elongate during**
A) Prophase I
B) Metaphase I
C) Telophase I
D) Anaphase I
- Q.185 Cell death due to tissue damage is called**
A) Necrosis
B) Metastasis
C) Apoptosis
D) Epistasis
- Q.186 When a disease is transmitted directly from an affected father to his son, it is called:**
A) X-linked
B) Autosomal
C) Y-linked
D) X and Y-linked
- Q.187 Epistasis is a relationship between:**
A) Alleles of a gene
B) Two different genes at the same locus
C) Two contrasting traits
D) Two different genes at different loci
- Q.188 Gene for albinism in man is present on chromosome number:**
A) 11
B) 22
C) 21
D) 12
- Q.189 Gene can be synthesized in laboratory from messenger RNA by using:**
A) Restriction enzymes
B) cDNA (complementary DNA)
C) Vector
D) Reverse transcriptase

- Q.190 Antibiotic resistance gene for tetracycline and ampicillin are present in the plasmid**
 A) pSC 101
 B) pCR 101
 C) pBR 322
 D) pBR 233
- Q.191 Cloning is a form of**
 A) Sexual Reproduction
 B) Asexual Reproduction
 C) Vegetative Propagation
 D) Genetic Recombination
- Q.192 Group of interbreeding individuals of particular species, sharing common geographical area is called:**
 A) Population
 B) Community ecology
 C) Community
 D) Autecology
- Q.193 Which of the following proteins is common in man and aerobic bacteria?**
 A) Haemoglobin
 B) Myoglobin
 C) Cytochrome c
 D) Pilin
- Q.194 Ozone filters ultraviolet radiations from the sun in the upper**
 A) Biosphere
 B) Atmosphere
 C) Lithosphere
 D) Hydrosphere
- Q.195 A parasite living inside body of the host is called**
 A) Ectoparasite
 B) Obligate parasite
 C) Facultative parasite
 D) Endoparasite
- Q.196 An association between two organisms benefiting both is called**
 A) Commensalism
 B) Parasitism
 C) Predation
 D) Symbiosis
- Q.197 In aquatic ecosystem, human activities may accelerate the process of**
 A) Eutrophication
 B) Photosynthesis
 C) Decomposition
 D) Recycling
- Q.198 Beri Beri is due to**
 A) Metabolic disorder
 B) Chemical causes
 C) Nutritional deficiency
 D) Mental Illness
- Q.199 The natural heat energy trapped underground is**
 A) Geothermal energy
 B) Thermal energy
 C) Electric energy
 D) Solar energy
- Q.200 Which of the following is the lowest level of biological organization with respect to others?**
 A) Multicellular organisms
 B) Biosphere
 C) Species
 D) Population
- Q.201 When an electron pair is shared between two atoms**
 A) Two covalent bonds are formed
 B) Hydrogen bond is formed
 C) Single covalent bond is formed
 D) Ionic bond is formed
- Q.202 The first microbe to have the genome completely sequenced and was published on July 28th, 1995 was**
 A) *Hyphomicrobium*
 B) *Haemophilus aquaticus*
 C) *Haemophilus malariae*
 D) *Haemophilus influenzae*
- Q.203 An activated enzyme consisting of polypeptide and a cofactor is known as**
 A) Amylase
 B) Apoenzyme
 C) Holoenzyme
 D) Coenzyme

- Q.204** _____ forms weak linkages with enzymes and their effect can be neutralized completely or partly by an increase in the concentration of the substrate.
A) Only competitive Inhibitors
B) Reversible inhibitors
C) Irreversible inhibitors
D) Both reversible and irreversible inhibitors
- Q.205** In prokaryotic cell, wall strengthening material is
A) Cellulose
B) Silica
C) Chitin
D) Peptidoglycan
- Q.206** The entire cell wall of bacteria is often regarded as a single huge molecule or molecular complex called
A) Capsule
B) Secondary wall
C) Slime capsule
D) Sacculus
- Q.207** Krebs's cycle takes place in
A) Ribosomes
B) Golgi apparatus
C) Mitochondria
D) Endoplasmic Reticulum
- Q.208** Chemically, viruses are made up of
A) Nucleic acid only
B) Protein only
C) Nucleic acid and protein
D) Core and coat
- Q.209** Widespread epidemic disease, influenza is caused by
A) DNA virus
B) RNA enveloped virus
C) DNA enveloped virus
D) RNA virus
- Q.210** When the division of cells is in three planes, the arrangement is known as
A) Diplococcus
B) Sarcina
C) Streptococcus
D) Staphylococcus
- Q.211** Bacterial 'death rate' is equal to 'birth rate; in
A) Lag phase
B) Log phase
C) Death phase
D) Stationary phase
- Q.212** Trypanosoma is a human parasite causing
A) African sleeping sickness
B) European sleeping sickness
C) Indonesian sleeping sickness
D) American sleeping sickness
- Q.213** The feeding stage of slime mold is a
A) Gastrozoid
B) Sporozoite
C) Plasmodium
D) Merozote
- Q.214** Drug obtained from fungus used for lowering blood cholesterol is
A) Lovastatin
B) Cyclosporin
C) Ergotin
D) Griseofulvin
- Q.215** Fungi store surplus food in the form of
A) Cellulose
B) Glycogen
C) Starch
D) Both B and C
- Q.216** The ecological role of fungi as decomposers is paralleled only by
A) Prions
B) Algae
C) Bacteria
D) Viruses
- Q.217** "Vascular System absent; gametophyte dominant, sporophyte attached to gametophyte; homosporous" are distinguishing characters of
A) Psilopsida
B) Pteropsida
C) Angiosperms
D) Bryophyta

Q.218 Which of the following features differentiate angiosperms from gymnosperms?

- A) Pollens disperse by air
- B) Haploid microspores
- C) Ovaries
- D) Pollen tubes

Q.219 In Pakistan, the furniture wood is mainly obtained from the members of family:

- A) Rosaceae
- B) Solanaceae
- C) Minosaceae
- D) Fabaceae

Q.220 Which of the following is exclusive character of mammals?

- A) Homeothermic
- B) Hair
- C) Poikliothermic
- D) Four chambered heart

(MCAT Preparations 2017 - ARK)

(Copyright Protected MCAT Preparations 2017 - ARK)

MBBS.COM.PK

MBBS.COM.PK

UHS MDCAT PAST PAPERS
BOOK Hard Copy Available
Now.

MBBS.COM.PK
EDUCATION SYSTEM

MDCAT GUIDE
UHS ENTRY TEST

MDCAT

PAST PAPER 2008-2019

- UNIT-WISE SOLVED MCQ's
- HIGHLIGHT REPEATED MCQ's
- CHANGING THE WAY YOU THINK
- BEST SOURCE TO GET HIGH MARKS
- UPDATED EDITION 2020
- AS PER UHS SYLLABUS

START
ENTRY TEST
PREPARATION
2020

LIVE CHAT
0304-7418334

Rs. 1400/=

Free Home Delivery

TO Book Order For MDCAT Past Papers
Call Or WhatsApp **0304-7418334**

University of Health Sciences, Lahore



Total MCQs: 220

Max. Marks: 1100

ENTRANCE TEST - 2011

For F.Sc. and Non-F.Sc. Students
Time Allowed: 150 minutes

Instructions:

- Read the instructions on the MCQs Response Form carefully.
- Choose the **Single Best Answer** for each question.
- Candidates are strictly prohibited from giving any identification mark except Roll No. & Signature in the specified columns only.

COMPULSORY QUESTION FOR IDENTIFICATION

Q-ID. What is the color of your Question Paper?

A) White.

C) Pink.

B)

Blue.

D) Green.

ID

Ans: Colour of your Question Paper is Green.
Fill the Circle Corresponding to Letter 'D'
against 'ID' in your MCQ response form
(Exactly as shown in the diagram).

	A	B	C	D
1	<input type="radio"/>	<input type="radio"/>	<input type="radio"/>	<input checked="" type="radio"/>
2	<input type="radio"/>	<input type="radio"/>	<input type="radio"/>	<input type="radio"/>
3	<input type="radio"/>	<input type="radio"/>	<input type="radio"/>	<input type="radio"/>
4	<input type="radio"/>	<input type="radio"/>	<input type="radio"/>	<input type="radio"/>

PHYSICS

- Q.1** When the dimensions of both sides of an equation are equal, then the equation is said to be
- A) Simultaneous
B) Homologous
C) Instantaneous
D) Quadratic
- Q.2** Radian is a unit of angular displacement which can also be measured in degrees. How many radians are equal to one degree?
- A) $\frac{180}{\pi}$
B) $\frac{\pi}{180}$
C) $\frac{2\pi}{180}$
D) $\frac{\pi}{57.3}$
- Q.3** An elevator is moving upwards with constant velocity of 'v'. What is a weight of a person of a mass 'm' inside the elevator during upward motion?
- A) $mg + mv$
B) mg
C) $mg - mv$
D) zero
- Q.4** An object having spherical shape of radius 'r' experiences a retarding force F from a fluid of coefficient of viscosity 'η' when moving through the fluid with speed 'v'. What is the ratio of retarding force to speed?
- A) $6\pi\eta r^2$
B) $6\pi\eta/r^2$
C) $6\pi\eta r$
D) $6\pi\eta/r$
- Q.5** When the drag force is equal to the weight of the droplet, the droplet will fall with:
- A) High Speed
B) Low Speed
C) Certain acceleration
D) Constant Speed

Q.6 A simple pendulum length ' L ' with bob of mass ' m ' is slightly displaced from its mean position so that its string makes an angle ' θ ' with vertical line as shown in the figure. Then bob of pendulum released. What will be the expression of torque with which the bob starts to move towards the mean position?

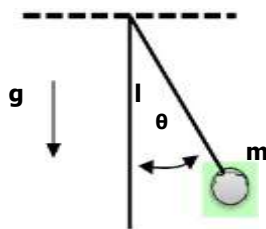

- A) mgL
- B) $mgL \sin \theta$
- C) 0
- D) $mgL \cos \theta$

Q.7 The density of blood is:

- A) Less than water
- B) Nearly equal to water
- C) Greater than water
- D) Three times that of water

Q.8 A monochromatic light of wavelength ' λ ' is used to produce the diffraction pattern through a single slit of width X . Which one of the following represents the intensity distribution across the screen?

A)

B)

D)

Q.9 For interference of light waves to take place, the required condition is

- A) The path difference of the light waves from the two sources must be large
- B) The interfering waves must be non-coherent
- C) The light waves may come from different sources
- D) The light waves must come from two coherent sources

Q.10 The property of bending of light around an obstacle and spreading of light waves into geometric shadow of an obstacle is called:

- A) Diffraction of Light
- B) Polarization of Light
- C) Quantization of Light
- D) Interference of Light

Q.11 The normal human eye can focus a sharp image of an object on the eye if the object is located at certain distance called

- A) Least Point
- B) Near Point
- C) Far Point
- D) Distinct Point

Q.12 A source of sound wave emits waves of frequency ' f '. If ' v ' is speed of sound waves, then what will be the wavelength of the waves

- A) $\frac{v}{f}$
- B) vf
- C) $\frac{v - u_0}{f}$
- D) $(v - u_0)f$

- Q.13** The spectrum of a star's light is measured and the wavelength of one of the lines as the sodium's line is found to be 589 nm. The same line has the wavelength of 497 nm when observed in the laboratory. This means the star is
- A) Moving away from the earth
B) Moving towards the north
C) Stationary
D) Revolving around the planet

- Q.14** What is the period of mass spring system during SHM if the ratio of mass to spring constant is $\frac{1}{4}$?
- A) π
B) 2π
C) $\frac{1}{\pi}$
D) $\frac{1}{2}\pi$

- Q.15** Waveform of SHM is given in figure. At what time/times displacement is equal to zero?

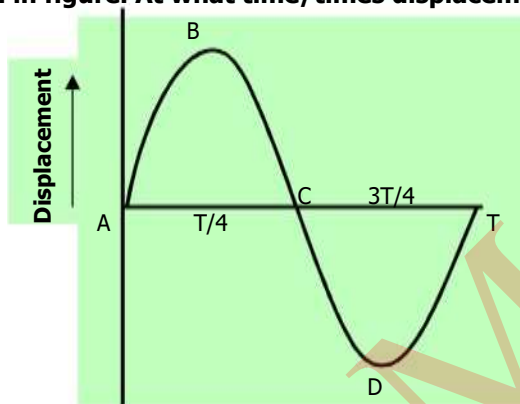

- A) $T/4$ only
B) $3T/4$ only
C) 0, $T/4$, $3T/4$ and T
D) 0, $T/2$ and T
- Q.16** A wire is stretched by a force which causes an extension. The energy is stored in it only when:
- A) The extension of wire is proportional to force applied
B) The cross-section area of the wire remains constant
C) The wire is not stretched beyond its elastic limit
D) The weight of wire is negligible
- Q.17** Which statement is correct:
- A) Elasticity is that property of body which enables body to regain its original dimension
B) Elasticity is that property of a body that does not allow it to return to its original shape
C) Elasticity is that property of a body that allows it to retain its original shape and dimension after the stress is removed.
D) Elasticity is that property of a body that obeys Hooke's law.

- Q.18** Which of the following is the expression of root mean square speed of a gas having n number of molecules contained in the container?

A) $\sqrt{\frac{v_1^2 + v_2^2 + \dots + v_n^2}{n}}$
B) $\sqrt{\frac{v_1^2 + v_2^2 + \dots + v_n^2}{N}}$
C) $\sqrt{\frac{v_1 + v_2 + \dots + v_n}{N}}$
D) $\sqrt{\frac{v_1 + v_2 + \dots + v_n}{N}}$

- Q.19** For a gas of volume V in its equilibrium state, if the pressure does change with time then total kinetic energy of gas is constant because

- A) Collisions between gas molecules occur
B) Collisions between gas molecules occur linearly
C) Collisions must be elastic
D) Collisions must be inelastic

- Q.20** Which of the following is the proper way to study the sinusoidal waveform of the voltage?

- A) Voltage is connected to X input and the time base is switched off
B) Voltage is connected to Y input and the time base is switched on
C) Voltage is connected to Y input and the time base is switched off
D) Voltage is connected to X input and the time base is switched on

- Q.21** Electron gun in cathode ray oscilloscope contains

- A) Filament, cathode, grid, anodes
B) Cathode, anode, capacitor, screen
C) Emitter, base, collector
D) Resistance, capacitor, inductor

Q.22 In which of the following, the change in internal energy is more?

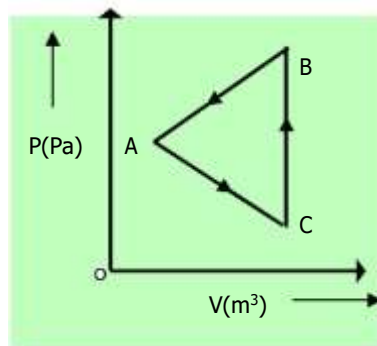
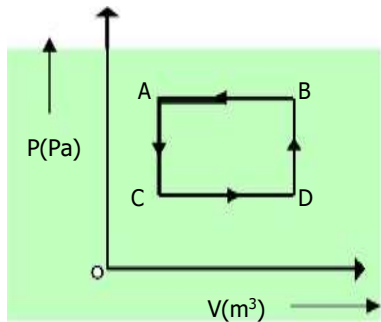

- A) In system A
- B) In system B

- C) Cannot be predicted
- D) Change is zero in both. (both are cyclic)

Q.23 Pressure volume graph of two systems 'A' and 'B' are plotted under isothermal and adiabatic conditions. Which of the following observation of graph represents the two systems?

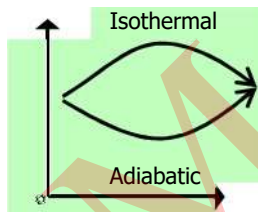
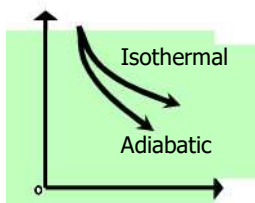

A)

C)

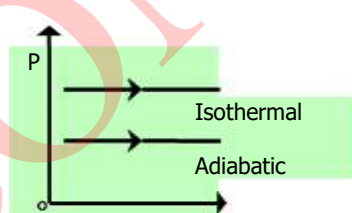
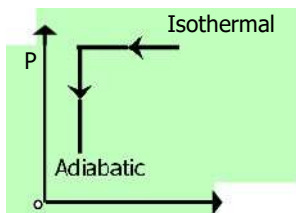

B)

D)

Q.24 Which of the following curve is an isotherm?

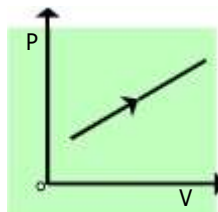
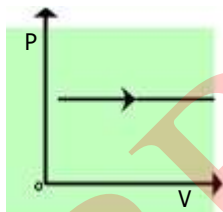

A)

C)

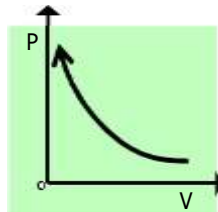
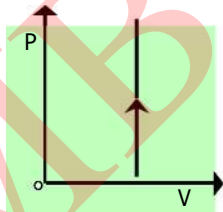

B)

D)

Q.25 If 2 A current passes through a resistor when connected to a certain battery. If the resistance is replaced by the double resistance, then the current will become

- A) 2 A
- B) 4 A

- C) 6 A
- D) 1 A

Q.26 In Helium-Neon laser, population inversion of _____ atoms is achieved which emit radiations, when they are stimulated to fall at lower level.

- A) Neon
- B) Helium

- C) Helium and Neon
- D) Chromium

- Q.27** Three resistors each having value 'R' are connected as shown in figure. What is the equivalence resistance between 'X' and 'Y'?

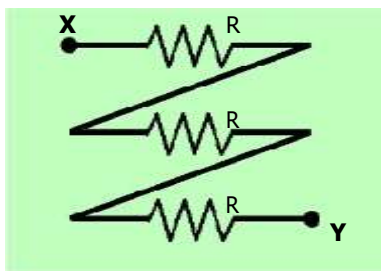

- A) $3R$
 B) R
 C) $R/3$
 D) R^3
- Q.28** If the number of turns of a solenoid circular coil is doubled, but the current in the coil and radius of the coil remains same, then what will be the magnetic flux density produced by the coil?
- A) Magnetic flux density will be halved
 B) Magnetic flux density increases by different amount at different points
 C) Magnetic flux density remains unchanged
 D) Magnetic flux density will be doubled
- Q.29** Two long parallel wires Wire 1 and Wire 2 repel each other as shown in the figure. What could be the reasons?

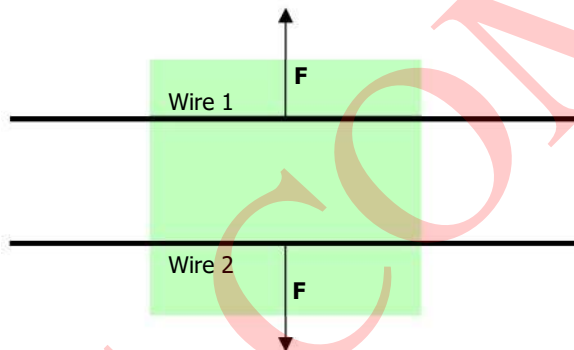

- A) Both carry current in same direction
 B) Both carry current in opposite direction
 C) Wire 1 has current, but Wire 2 has no current
 D) Wire 2 has current, Wire 1 has no current
- Q.30** The diagram shows a wire, carrying a current 'I', placed between the poles of a magnet: In which direction does the force on the wire act?

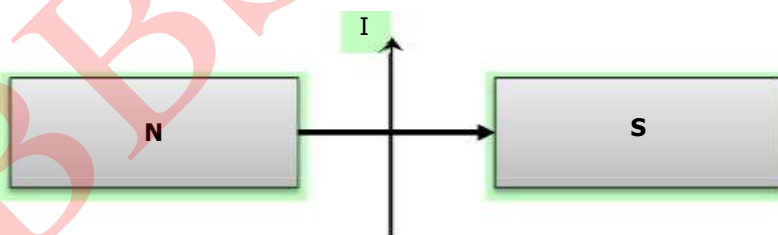

- A) Upwards
 B) Downwards
 C) Towards the 'N' pole of the magnet
 D) Towards the 'S' pole of the magnet
- Q.31** Wavelength of X-rays is the order of:
- A) 10^{-6} m
 B) 10^{-10} m
 C) 10^{-13} m
 D) 100 m
- Q.32** Laser beam can be used to generate three-dimensional image of object in a process called:
- A) Computed technology
 B) Computed tomography
 C) Holography
 D) Computerized axial tomography
- Q.33** Which of the following is true for Lasers?
- A) Electrons are emitted
 B) Stimulated emission of electrons is needed
 C) Coherent monochromatic light is emitted
 D) There is a population inversion of photons

Q.34 Three resistors of resistance R_1 , R_2 and R_3 are connected as shown in figure. Equivalence resistance is:

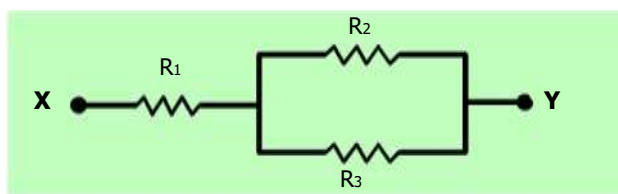

A) $R_1 + R_2 + R_3$
 B) $\frac{R_1 + R_2 + R_3}{R_1 R_2}$

C) $\frac{R_1 R_2 + R_2 R_3 + R_2 R_3}{R_1 + R_2}$
 D) $\frac{R_1 R_2 R_3}{R_2 R_3}$

Q.35 What is meant by spontaneous emission of electrons in solids?

- A) Electrons being emitted by the solids through photoelectric effect when irradiated with electromagnetic radiation
- B) Incident electrons colliding with electrons in solids and releasing doubling the number of incident electrons
- C) Electrons in solids are emitted without any external stimulus through radiation
- D) Excited electrons going back to lower energy states immediately by releasing energy.

Q.36 When electrons lose all their kinetic energy in the first collision, the entire kinetic appears as an X-ray photon of energy:

A) $K.E = eV$
 B) $K.E = \frac{h\lambda_{min}}{c}$
 C) $K.E = \frac{hc}{\lambda_{min}}$
 D) $K.E = \frac{h}{\lambda_{max}}$

Q.37 The characteristic X-ray spectrum is due to:

- A) The absorption of neutrons by target material
- B) The bombardment of target material by protons
- C) The bombardment of target material by electrons
- D) The bombardment of target material by alpha particles

Q.38 Ionizing capability of gamma rays is:

- A) Equal to alpha and beta particle
- B) Less than alpha but greater than beta particles
- C) Less than both alpha and beta particles
- D) Less than beta but greater than alpha particles

Q.39 Half-life of a radioactive element is:

- A) Inversely proportional to square of decay constant
- B) Directly proportional to square of decay constant
- C) Directly proportional to decay constant
- D) Inversely proportional to decay constant

Q.40 The transformation of a neutron into proton in the nucleus gives rise to emission of:

- A) Beta particles
- B) Alpha particles
- C) Gamma particles
- D) X-rays

Q.41 The ratio of the rate of decay of a parent atom to the number of radioactive nuclei present at that time is equal to:

- A) Half-life of radioactive element
- B) Mean life
- C) Decay constant of radioactive element
- D) Activity of radioactive element

Q.42 Which one of the following particle is emitted as a result of nuclear reaction?



- A) Beta
- B) Alpha
- C) Gamma rays
- D) One alpha and one beta

Q.43 Which of following is used to estimate the circulation of blood in a patient?

- A) Carbon-14
- B) Carbon-12
- C) Phosphorus-32
- D) Sodium-24

Q.44 For the radiotherapy of a patient, it is required to double the absorbed dose in gray. What step must be taken?

- A) Energy must be quadrated
- B) Energy must be halved
- C) Energy must be raised four times
- D) Energy must be doubled

CHEMISTRY

- Q.45 In mass spectrometer, detector or collector measures the:**
 A) Masses of isotopes
 B) Percentages of isotopes
 C) Relative abundances of isotopes
 D) Mass numbers of isotopes
- Q.46 How many 'Cl' (chlorine) atoms are in two moles of chlorine?**
 A) $2 \times 6.02 \times 10^{-23}$ atoms
 B) $35.5 \times 6.02 \times 10^{23}$ atoms
 C) 2×10^{23} atoms
 D) $2 \times 6.02 \times 10^{23}$ atoms
- Q.47 Melting point of water is higher than petrol, because intermolecular forces in water are:**
 A) Weaker than petrol
 B) Stronger than petrol
 C) Same as in petrol
 D) Negligible
- Q.48 DNA molecule is double stranded, in which two chains of DNA are twisted around each other by:**
 A) Hydrogen bonds
 B) Vander Waal's force
 C) Covalent bonds
 D) Dative bonds
- Q.49 The elements for which the value of ionization energy is low, can:**
 A) Gain electrons readily
 B) Gains electron with difficulty
 C) Loss electrons less readily
 D) Lose electrons readily
- Q.50 The nature of cathode rays in discharge tube:**
 A) Depends on the nature of gas taken in the discharge tube
 B) Depends upon the nature of cathode in discharge tube
 C) Is independent of the nature of the gas in discharge tube
 D) Depends upon the nature of anode in the discharge tube
- Q.51 The ability of an atom in a covalent bond to attract the bonding electrons is called:**
 A) Ionization energy
 B) Ionic bond energy
 C) Electronegativity
 D) Electron affinity
- Q.52 The paramagnetic character of a substance is due to:**
 A) Bond pairs of electrons
 B) Lone pairs of electrons
 C) Unpaired electrons in atom or molecule
 D) Paired electrons in valence shells of electrons
- Q.53 Lattice energy of an ionic crystal is the enthalpy of:**
 A) Combustion
 B) Dissociation
 C) Dissolution
 D) Formation
- Q.54 In standard enthalpy of atomization, heat of the surrounding:**
 A) Remains unchanged
 B) Increases
 C) Increases than decreases
 D) Decreases
- Q.55 Mole fraction of any compound is the ratio of moles of all components in a:**
 A) Compound
 B) Solution
 C) Molecule
 D) Solid
- Q.56 Molarity is defined as the number of moles of any substance dissolved:**
 A) Per dm^3 of water
 B) In one gram of water
 C) Per m^3 of water
 D) In 100 ml of water
- Q.57 In electrolytic cell, a salt bridge is used in order to:**
 A) Pass the electric current
 B) Prevent the flow of ions
 C) Mix solution of two half cells
 D) Allow movement of ions b/w two half cells
- Q.58 In all oxidation reactions, atoms of an element in a chemical species lose electrons and increase their:**
 A) Oxidation states
 B) Reductions
 C) Electrode
 D) Negative charges
- Q.59 In 'AgCl' solution. Some salt of NaCl is added, 'AgCl' will be precipitated due to:**
 A) Solubility
 B) Electrolyte
 C) Unsaturation effect
 D) Common ion effect

Q.60 'Ka' for an acid is higher, the stronger is the acid; relate the strength an acid with 'pKa'

- A) Higher pKa, weaker the acid
 B) Lower pKa, stronger the acid
 C) pKa has no relation with acid strength
 D) Both A and B

Q.61 It is experimentally found that a catalyst is used to:

- A) Lower the activation energy
 B) Increase the activation energy
 C) Lower the pH
 D) Decrease the temp of the reaction

Q.62 According to collision theory of bimolecular reaction sin gas phase, the minimum amount of energy required for an effective collision is known as:

- A) Heat of reaction
 B) Rate of reaction
 C) Has no effect on the reaction
 D) Energy of activation

Q.63 Carbon exists as allotropes, which are different crystalline or molecular forms of the same substance. Graphite and diamond are allotropes of carbon. Diamond is a non-conductor whereas graphite is a good conductor because:

- A) Graphite has a layered structure
 B) In graphite, all valence electrons are tetrahedrally bound
 C) In graphite one of valence electron is free to move
 D) Graphite is soft and greasy

Q.64 The diagram below is a plot of melting points of elements of second period against their atomic numbers. Lithium and fluorine are placed at the extreme ends of the plot, on the basis of melting points where will you place Carbon among the empty slots on the plot?

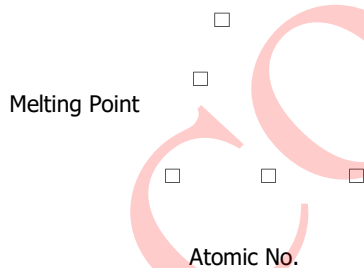

- A) 1
 B) 2
 C) 4
 D) 3

Q.65 When elements of group II-A (alkaline earth metals) are exposed to air, they quickly become coated with a layer of oxide. What is the purpose of this oxide layer?

- A) The oxide layer exposes the metal to Atmospheric attack
 B) The oxide layer increases the reactivity of metal
 C) The oxide layer protects the metal from further atmospheric attack
 D) The oxide layer gives the metal a shiny silvery appearance

Q.66 In silicon dioxide each silicon atom is tetrahedrally bonded to four oxygen atoms and each oxygen atom is bonded to two silicon atoms. The ratio of silicon to oxygen atoms is:

- A) 2:2
 B) 1:2
 C) 2:1
 D) 1:4

Q.67 Hydrogenation of unsaturated oils is done by using:

- A) Finally divided nickel
 B) Finally divided iron
 C) Vanadium pentoxide
 D) Copper

Q.68 Pick the correct statement:

- A) Chelates are usually more stable than ordinary complexes
 B) Ordinary complexes are more stable than chelates
 C) Monodentate ligands form the chelates
 D) Chelates have no ring structures

Q.69 In contact process, the catalyst used for the conversion of Sulphur dioxide to Sulphur trioxide is:

- A) Magnesium oxide
 B) Aluminum oxide
 C) Silicon dioxide
 D) Vanadium pentoxide

- Q.70** The unpolluted natural rain water is slightly acidic due to the reaction of rain water with:
- A) Sulphur dioxide
B) Oxides of nitrogen
C) Carbon dioxide
D) Hydrogen present in air
- Q.71** In the Haber's process for the manufacturing of ammonia, nitrogen is taken from:
- A) Proteins occurring in living bodies
B) Ammonium salts obtained industrially
C) Air
D) Mineral containing nitrates
- Q.72** In comparison with oxygen gas, a strong triple bond is present between two nitrogen atoms in a molecule and therefore nitrogen gas is:
- A) Highly reactive gas
B) Completely inert like noble gases
C) Very less reactive gas
D) Moderately reactive gas
- Q.73** The compound with an atom, which has unshared pair of electrons is called:
- A) Nucleophile
B) Electrophile
C) Protophile
D) None of the above
- Q.74** 1-chloropropane and 2-chloropropane are isomers of each other, the type of isomerism in these two is called:
- A) Cis-trans isomerism
B) Chain isomerism
C) Position isomerism
D) Functional group isomerism
- Q.75** Benzene in the presence of AlCl_3 produces acetophenone when reacts with:
- A) Acetyl chloride
B) Acetic acid
C) Ethyl benzene
D) Ethanoic acid
- Q.76** The substitution of a '-H' by '-NO₂' group in benzene is called:
- A) Nitration
B) Ammunolusis
C) Sulphonation
D) Reduction of benzene
- Q.77** When purely alcoholic solution of sodium/potassium hydroxide and halogenoalkanes are reacted an alkene is formed, what is the mechanism of reaction?
- A) Elimination
B) Dehydration
C) Debromination
D) Reduction of benzene
- Q.78** The organic compound carbon tetrachloride is used as:
- A) Lubricant
B) Solvent
C) Oxidant
D) Plastic
- Q.79** An alcohol is converted to an aldehyde with same number of carbon atoms as that of alcohol in the presence of $\text{K}_2\text{Cr}_2\text{O}_7/\text{H}_2\text{SO}_4$ the alcohol is:
- A) $\text{CH}_3\text{CH}(\text{CH}_3)_2\text{OH}$
B) $\text{CH}_3\text{CH}_2\text{CH}_2\text{OH}$
C) $(\text{CH}_3)_3\text{COH}$
D) $(\text{CH}_3)_3\text{CHOH}$
- Q.80** Which of the following is a secondary alcohol?
- A) $\begin{array}{c} \text{H}_3\text{C}-\text{CH}-\text{OH} \\ | \\ \text{CH}_3 \end{array}$
B) $\text{H}_3\text{C}-\text{CH}_2-\text{CH}_2-\text{OH}$
C) $\begin{array}{c} \text{H}_3\text{C}-\text{CH}-\text{CH}_2-\text{OH} \\ | \\ \text{CH}_3 \end{array}$
D) $\begin{array}{c} \text{CH}_3 \\ | \\ \text{H}_3\text{C}-\text{CH}-\text{CH}_2-\text{C}-\text{CH}_3 \\ | \quad | \\ \text{CH}_3 \quad \text{OH} \end{array}$
- Q.81** Which enzyme is involved in the fermentation of glucose:
- A) Zymase
B) Invertase
C) Urease
D) Diastase
- Q.82** Relative acidic strength of alcohol, phenol, water and carboxylic acid is:
- A) Carboxylic acid > Alcohol > Phenol > Water
B) Carboxylic acid > Phenol > Water > Alcohol
C) Phenol > Carboxylic acid > Alcohol > Water
D) Water > Alcohol > Phenol > Carboxylic acid

Q.83 Consider the following reaction:

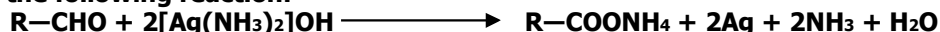

This reaction represents one of the following tests.

- A) Fehling test
 B) Benedict test
 C) Ninhydrin test
 D) Tollens test

Q.84 In the below reaction, the nucleophile is:

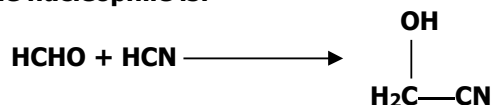

- A) CN^-
 B) HCl
 C) Cl^-
 D) OH^-

Q.85 Which one of the following compound belongs to the homologous series of aldehydes?

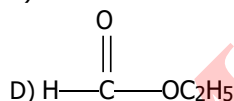
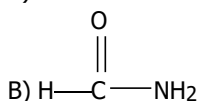
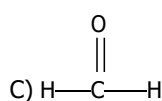
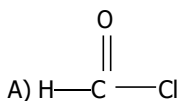

Q.86 $\text{CH}_3\text{COOH} + \text{PCl}_5 \longrightarrow ?$

The products of the above reaction are:

- A) $\text{CH}_3\text{COI} + \text{POCl}_3 + \text{HCl}$
 B) $\text{CH}_3\text{COI} + \text{POCl}_2 + \text{HCl}$
 C) $\text{CH}_3\text{Cl} + \text{POCl}_3 + \text{HCl}$
 D) $\text{CH}_3\text{COCl} + \text{POCl}_3 + \text{H}_2$

Q.87 $\text{CH}_3\text{CN} + \text{HCl} \longrightarrow \text{A} + \text{B}$ (in the presence of water)

In the above reaction, A and B are:

- A) Acetic acid and acid amide
 B) Acetic acid and ammonia
 C) Acetic acid and methyl chloride
 D) Acetic acid and ammonium chloride

Q.88 Consider the following reaction:



What product will form?

- A) Magnesium formate
 B) Magnesium acetate
 C) Magnesium ion
 D) Carboxylate ion

Q.89 The $-\text{NH}-\text{CO}$ is called:

- A) Amide group
 B) Amino group
 C) Protein linkage
 D) Peptide linkage

Q.90 Which one of the following is an alpha amino acid?

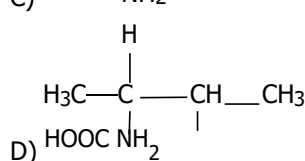
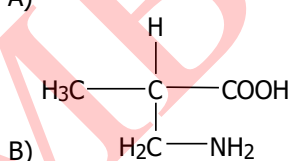
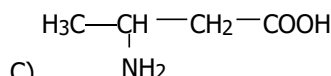
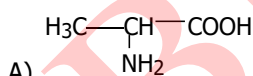

Q.91 Which of the following has an amino R-group?

- A) Lysine
 B) Proline
 C) Valine
 D) Alanine

Q.92 At intermediate value of pH, amino acids form Zwitter ions containing:

- A) $-\text{N}^+\text{H}_3$ and COO^-
 B) $-\text{NH}_3$ and COO^-
 C) $-\text{N}^+\text{H}_3$ and COOH
 D) $-\text{NH}_3$ and COOH

Q.93 When hexane dioic acid is heated with hexamethylene diamine, the compound formed is:

- A) Polypeptide
 B) Addition polymer
 C) Ester
 D) Nylon 6,6

- Q.94** A polymer in which the number of amino acid residue is greater than 100 or molecular mass is greater than 1000, is known as:
 A) Protein
 B) Polypeptide
 C) Dipeptide
 D) Tripeptide
- Q.95** Aspartic acid is an acidic amino acid, which has chemical formula:
 A) $\begin{array}{c} \text{H}_3\text{C}-\text{CH}-\text{COOH} \\ | \\ \text{NH}_2 \\ | \\ \text{H} \\ | \\ \text{H}_2\text{N}-\text{C}-\text{COOH} \\ | \\ \text{H}_2\text{C}-\text{COOH} \end{array}$
 B) $\begin{array}{c} \text{H}_3\text{C}-\text{CH}-\text{COOH} \\ | \\ \text{NH}_2 \\ | \\ \text{H} \\ | \\ \text{H}_3\text{C}-\text{C}-\text{CH}-\text{COOH} \\ | \quad | \\ \text{H} \quad \text{NH}_2 \end{array}$
 C) $\begin{array}{c} \text{H}_3\text{C}-\text{CH}-\text{CH}_2-\text{COOH} \\ | \\ \text{NH}_2 \\ | \\ \text{H} \\ | \\ \text{H}_3\text{C}-\text{C}-\text{CH}-\text{COOH} \\ | \quad | \\ \text{H} \quad \text{NH}_2 \end{array}$
 D) $\begin{array}{c} \text{H}_3\text{C}-\text{CH}-\text{COOH} \\ | \\ \text{NH}_2 \\ | \\ \text{H} \\ | \\ \text{H}_3\text{C}-\text{C}-\text{CH}-\text{COOH} \\ | \quad | \\ \text{H} \quad \text{NH}_2 \end{array}$
- Q.96** Glucose and fructose are common examples of:
 A) Pentoses
 B) Hexoses
 C) Heptoses
 D) Butoses
- Q.97** The reaction between fats and caustic soda is called:
 A) Hydrogenolysis
 B) Fermentation
 C) Carboxylation
 D) Saponification
- Q.98** Macromolecules are described as large molecules built up from small repeating units known as:
 A) Monomers
 B) Isomers
 C) Metameres
 D) Tautomer
- Q.99** Polyvinyl chloride is an example of:
 A) Addition polymer
 B) Condensation polymer
 C) Biopolymer
 D) Thermosetting polymer
- Q.100** Terylene, a polyester is an example of:
 A) Biopolymer
 B) Lipids
 C) Condensation polymer
 D) Addition polymer
- Q.101** The suspected liver carcinogen which also has negative reproduction and developmental effect on humans is:
 A) Iodoform
 B) Bromoform
 C) Tropoform
 D) Chloroform
- Q.102** Peroxyacetyl nitrate is an irritant to human beings and its effects:
 A) Nose
 B) Stomach
 C) Ears
 D) Eyes

ENGLISH

- Q.103** She managed to _____ a ticket for the cricket match.
 A) Procure
 B) Obscure
 C) Improvise
 D) Preclude
- Q.104** Things have got out of hand; we must take steps to _____ the situation
 A) Rectify
 B) Pacify
 C) Purify
 D) Testify
- Q.105** George Orwell's animal farm is a stinging _____ on the Russian revolution
 A) Myth
 B) Satire
 C) Fallacy
 D) Legend
- Q.106** All the _____ and ceremony of the royal wedding was telecast on the national television circuit.
 A) Festival
 B) Romp
 C) Pomp
 D) Happiness

⇒ **SPOT THE ERROR: In the following sentences, some segments of each sentence are underlined. Your task is to identify that underlined segment of the sentence, which contains the mistake that needs to be corrected. Fill the Circle corresponding to that letter under the segment in the MCQ Response Form.**

- Q.107** The patient's blood analysis shows that there is a big number of amorphous cells which are quiet unidentifiable.
 A) B) C) D)
- Q.108** The police, in their investigation, used coercive measure to get favorable statement from the accused.
 A) B) C) D)
- Q.109** Your argument is simply abstruse as there is no clarity of thought and coherence in ideas and it also lack vision.
 A) B) C) D)
- Q.110** The workers were raising much hue and cry when their demands were turned away.
 A) B) C) D)
- Q.111** The disease is uncurable without the judicious use of antibiotics.
 A) B) C) D)
- Q.112** The younger sister hopes to emulate her elder sister's sporting achievement as she is putting up hectic effort.
 A) B) C) D)

⇒ **In each of the following question, four alternative sentences are given. Choose the CORRECT one and fill the Circle corresponding to that letter in the MCQ Response Form.**

- Q.113**
 A) The government should accrue taxes for strengthen the economy of the country.
 B) The government should accrue taxes in strengthen the economy of the country.
 C) The government should accrue taxes to strengthen the economy of the country.
 D) The government should accrue taxes by strengthen the economy of the country.
- Q.114**
 A) Foreign trade have assumed greater importance in recent years.
 B) Foreign trade is assumed greater importance in recent years.
 C) Foreign trade has assumed greater importance in recent years.
 D) Foreign trade shall assumed greater importance in recent years.
- Q.115**
 A) The space programme has been battered in bureaucratic wrangling.
 B) The space programme has been battered into bureaucratic wrangling.
 C) The space programme has been battered by bureaucratic wrangling.
 D) The space programme has been battered to bureaucratic wrangling.
- Q.116**
 A) He will has to deal with the problem by showing adroitness.
 B) He will have to deal with the problem by showing adroitness.
 C) He will had to deal with the problem by showing adroitness.
 D) He will having to deal with the problem by showing adroitness.
- Q.117**
 A) He does possesses altruistic behavior.
 B) He does possess altruistic behavior.
 C) He does possessing altruistic behavior.
 D) He does possessed altruistic behavior.
- Q.118**
 A) He has great affinity in nature.
 B) He has great affinity with nature.
 C) He has great affinity by nature.
 D) He has great affinity at nature.
- Q.119**
 A) He stands on arms akimbo.
 B) He stands to arms akimbo.
 C) He stands with arms akimbo.
 D) He stands through arms akimbo.

Q.120

- A) An amorphous mass of cells are difficult to understand.
- B) An amorphous mass of cells were difficult to understand.
- C) An amorphous mass of cells had difficult to understand.
- D) An amorphous mass of cells is difficult to understand.

Q.121

- A) He is suffering to anaphylactic shock.
- B) He is suffering in anaphylactic shock.
- C) He is suffering from anaphylactic shock.
- D) He is suffering into anaphylactic shock.

Q.122

- A) If you had asked him, he would had accepted the offer with alacrity.
- B) If you had asked him, he would have being accepted the offer with alacrity.
- C) If you had asked him, he would have accepted the offer with alacrity.
- D) If you had asked him, he would been accepted the offer with alacrity.



In each of the following question, four alternative meanings of a word are given. You have to select the NEAREST CORRECT MEANING of the given word and fill the appropriate Circle on the MCQ Response Form.

Q.123 **MUSE**

- A) Wander
- B) Fonder
- C) Robust
- D) Ponder

Q.124 **FECKLESS**

- A) Useless
- B) Careless
- C) Dauntless
- D) Fearless

Q.125 **MOSAIC**

- A) Pattern
- B) Mortal
- C) Ordinary
- D) Musical

Q.126 **INSCRUTABLE**

- A) Immoral
- B) Unethical
- C) Enigmatic
- D) Unaccountable

Q.127 **JUXTAPOSE**

- A) Justify
- B) Compare
- C) Expose
- D) Jettison

Q.128 **LACERATING**

- A) Landing
- B) Tearing
- C) Flagging
- D) Lactating

Q.129 **EMPATHY**

- A) Fictitious
- B) Facility
- C) Ability
- D) Felicity

Q.130 **EVANESCENT**

- A) Evident
- B) Permanent
- C) Event
- D) transitory

Q.131 **SIDLE**

- A) Sneak
- B) Sift
- C) Sledge
- D) Sieve

Q.132 **DISSONANCE**

- A) Inconsistency
- B) Expansion
- C) Perceptible
- D) WrapPart

BIOLOGY

- Q.133** When chromosomes uncoil, the nucleoli are reformed and two nuclei are the two poles of the cell; stage is known as
A) Prophase
B) Metaphase
C) Telophase
D) Anaphase
- Q.134** Mental retardation, short stature, broad face and squint eyes are the symptoms of
A) Down's syndrome
B) Klinefelter's syndrome
C) Turner's syndrome
D) XYZ syndrome
- Q.135** Chiasmata formation takes place during the process which is known as
A) Crossing Over
B) Attachment
C) Pairing
D) Leptotene
- Q.136** Healing of a wound and repair is the phenomenon which takes place by the process of
A) Mitosis
B) Meiosis
C) Cell Growth
D) Mitosis & Meiosis
- Q.137** Which one of the following is the main cause of cancer?
A) Mutation
B) Controlled Cell Division
C) Regulated Mitosis
D) Haploid Division
- Q.138** The covalent bond formed between two monosaccharides is called
A) Glycosidic Bond
B) Hydrogen Bond
C) Peptide Bond
D) Disulphide
- Q.139** The bond formed between glucose and fructose form sucrose is
A) 1,4 Glycosidic Linkage
B) 1,2 Glycosidic Linkage
C) 1,6 Glycosidic Linkage
D) 1,3 Glycosidic Linkage
- Q.140** In an amino acid in which the R-group is H, its name will be
A) Alanine
B) Glycine
C) Leucine
D) Valine
- Q.141** Fatty acid are the organic compounds containing hydrogen, oxygen and one of the following are
A) -COOH
B) -NH₂
C) Acyl
D) Sucrose
- Q.142** Posomes are used in gene therapy against
A) Hypercholesterolemia
B) Coronary Artery Angioplasty
C) Cystic Fibrosis
D) Severe Combined Immunodeficiency Syndrome (SCID)
- Q.143** Genetically engineered cells are introduced into bone marrow cells in the treatment of
A) Hypercholesterolemia
B) Severe Combined Immunodeficiency Syndrome (SCID)
C) Cystic Fibrosis
D) Coronary Artery Angioplasty
- Q.144** Which one of the following is depleting and causing thinning of ozone?
A) Chlorine
B) Bromine
C) Chlorofluorocarbon
D) Carbon
- Q.145** The typical environment of a particular organism population community is called
A) Niche
B) Ecosystem
C) Habitat
D) Biosphere
- Q.146.** Excessive enrichment of water with nutrients by human activity by which large amount of living organic matter grows is called
A) Archeotrophication
B) Eutrophication
C) Enrichment
D) Low Trophication

- Q.147 In an ecosystem, mycorrhizae is an example of**
 A) Symbiosis
 B) Predation
 C) Commensalism
 D) Parasitism
- Q.148 Successive stages of eating and being eaten by which recycling of materials and flow of energy takes place is called**
 A) Food Chain
 B) Food Web
 C) Trophic Level
 D) Food Link
- Q.149 The sex of individuals of next generation always depends on one of the parents who is**
 A) Heterogametic
 B) Homogametic
 C) Isogametic
 D) Isomorphic
- Q.150 Which of the following will be hemophilic?**
 A) $X^H X^h$
 B) $X^H X^H$
 C) $X^h Y$
 D) $X^H Y$
- Q. 151 Which of the following is an example of X-linked recessive trait in humans?**
 A) Hypophosphatemic Rickets
 B) Colour Blindness
 C) Baldness
 D) Beard Growth
- Q.152 Which trait in human is an example of multiple alleles?**
 A) Eye Colour
 B) Skin Colour
 C) ABO-Blood Group
 D) Rh-Blood Group
- Q.153 When a gene pair at one locus interacts with another gene at another locus, the interaction is called**
 A) Dominance
 B) Multiple Alleles
 C) Pleiotropy
 D) Epistasis
- Q.154 The combination of a pentose sugar with a base result in a compound is known as**
 A) Nucleotide
 B) Nucleoside
 C) Nucleic Acid
 D) Polynucleotide
- Q.155 An enzyme and substrate reacts through a special feature or site present in enzyme:**
 A) Building Site
 B) Active Site
 C) Catalyst Site
 D) Inhibition Site
- Q.156 The non-protein part of enzyme which is covalently and permanently bonded is called**
 A) Prosthetic Group
 B) Co-Factor
 C) Co-Enzyme
 D) Activator
- Q.157 One of the pyrimidine bases is absent in DNA**
 A) Uracil
 B) Thymine
 C) Cytosine
 D) Adenine
- Q.158 Enzymes increase the rate of reaction by**
 A) Increasing Temperature
 B) Decreasing pH
 C) Decreasing Activation Energy
 D) Increasing Activation Energy
- Q.159 Which one of the following diseases caused by enveloped RNA virus and spread in epidemic form?**
 A) Influenza
 B) Herpes Simplex
 C) Polio
 D) Small Pox
- Q.160 The structure which contains the gene for drug resistance bacteria are**
 A) Nucleoids
 B) Mesosomes
 C) Chromatin Bodies
 D) Plasmids
- Q.161 Antibiotics that kill microbes immediately are called**
 A) Microbistatic
 B) Microbicidal
 C) Biostatic
 D) Chemotherapeutic

Q.162 Which one of the following fungi causes vaginal thrush?

- A) Candida
- B) Aspergillus
- C) Tortula
- D) Penicillium

Q.163 Body cavity of round worms is called

- A) Pseudocoelom
- B) Coelom
- C) Acoelom
- D) Enteron

Q.164 Fasciola is endoparasite of

- A) Colon
- B) Liver
- C) Small Intestine
- D) Bile Duct

Q.165 Trypanosoma is transmitted in human beings by

- A) Plasmodium
- B) Anopheles
- C) House Fly
- D) Tsetse Fly

Q.166 The nervous system develops from which of the following layer during embryonic development of animals

- A) Mesoderm
- B) Ectoderm
- C) Endoderm
- D) Mesoderm and Endoderm

Q.167 Endosperm is formed as a result of

- A) Pollination
- B) Self-Pollination
- C) Double Fertilization
- D) Cross Pollination

Q.168 Which of the following enzyme is released in an inactive form

- A) Amylase
- B) Lipase
- C) Enterokinase
- D) Pepsin

Q.169 Which of the following hormones stimulate the secretion of pancreatic juice from pancreas in liver?

- A) Secretin
- B) Pepsinogen
- C) Gastrin
- D) Both Gastrin and Secretin

Q.170 In large intestine, vitamin k is formed by the activity of

- A) Symbiotic Bacteria
- B) Obligate Bacteria
- C) Parasitic Bacteria
- D) Facultative Bacteria

Q.171 During swallowing of food which structure close nasal opening?

- A) Hard Palate
- B) Soft Palate
- C) Epiglottis
- D) Larynx

Q.172 The right atrium of the heart usually receives the

- A) Deoxygenated Blood
- B) Oxygenated Blood
- C) Filtered Blood
- D) Non-Filtered Blood

Q.173 The largest lymph duct called thoracic lymph duct drains into

- A) Subclavian Vein
- B) Renal Vein
- C) Pulmonary Vein
- D) Hepatic Portal Vein

Q.174 Which protein plays a major role in maintaining osmotic balance?

- A) Albumin
- B) Globulin
- C) Fibrinogen
- D) Prothrombin

Q.175 The type of agranulocytes which stays in blood for a few hours and then enters tissues and become macrophages are

- A) Lymphocytes
- B) Monocyte
- C) Eosinophils
- D) Basophils

Q.176 Reabsorption of water by counter current multiplier mechanism takes place at

- A) Proximal Tubule
- B) Distal Tubule
- C) Collecting Duct
- D) Loop of Henle

- Q.177 Antidiuretic hormone helps in reabsorption of water by changing permeability of**
 A) Proximal Tubule C) Collecting Duct
 B) Distal Tubule D) Loop of Henle
- Q.178 During peritoneal dialysis, dialysis fluid is introduced into which part of human body?**
 A) Liver C) Kidney
 B) Abdomen D) Pancreas
- Q.179 Aldosterone helps in conservation or active absorption of**
 A) Sodium C) Potassium
 B) Calcium D) Bicarbonate Ions
- Q.180 Maximum reabsorption takes place in which part of the nephron?**
 A) Distal Tubule C) Cortical Tissue
 B) Villi D) Proximal Tubule
- Q.181 Over-activity of sympathetic nervous system causes**
 A) Disturbance of Vision C) Decrease in Blood Pressure
 B) Constipation D) Increase in Heart Rate
- Q.182 Which structures respond when they are stimulated by impulse coming through motor neuron?**
 A) Receptors C) Effectors
 B) Responses D) Transduction
- Q.183 Respiratory center is located in**
 A) Cerebrum C) Medulla
 B) Cerebellum D) Hypothalamus
- Q.184 A neurological condition characterized by involuntary tremors, diminished motor activity and rigidity is called**
 A) Epilepsy C) Alzheimer's Disease
 B) Parkinson's Disease D) Cerebellar Tumours
- Q.185 A type of cell in human testes which produces testosterone is called**
 A) Interstitial Cells C) Sertoli Cells
 B) Germ Cells D) Spermatocytes
- Q.186 Breakdown of endometrium during menstruation is due to**
 A) Increase in Level of LH C) Increase in Level of Progesterone
 B) Decrease in Level of Progesterone D) Increase in Level of Oestrogen
- Q.187 Oogonia are produced in the germ cells**
 A) Both Uterus and Cervix C) Uterus
 B) Cervix D) Ovary
- Q.188 Which of the following diseases can be prevented through vaccination?**
 A) AIDS and Cancer C) Typhoid and Cancer
 B) Malaria and AIDS D) Measles and Mumps
- Q.189 Newly produced cells/individuals which are identical in each other are known as**
 A) Genetically Modified C) Transgenic Bacteria
 B) Transgenic Animals D) Clones
- Q.190 Which of the following is a blood borne disease?**
 A) Hepatitis C) Influenza
 B) Cholera D) Candidiasis
- Q.191 The control of pest has traditionally meant regulation by natural enemies, predators, parasites and pathogens. This type of control is known as**
 A) Cultural Control C) Pesticides Control
 B) Biological Control D) Insecticides Control

Q.192 Which of the following organelles is concerned with the cell secretion

- A) Ribosomes
- B) Golgi Apparatus
- C) Lysosomes
- D) Mitochondria

Q.193 Which of the following contains peptidoglycan cell wall?

- A) Penicillium
- B) Bacterium
- C) Adiantum
- D) Polytrichum

Q.194 The inner membrane of mitochondria is folded to form finger like structure called

- A) Cristae
- B) Vesicle
- C) Matrix
- D) Cisternae

Q.195 Interior of chloroplast is divided into heterogeneous structure, embedded in the matrix known as

- A) Grana
- B) Stroma
- C) Thylakoids
- D) Cisternae

Q.196 In which phase of the cell division the metabolic activity of the nucleus is high?

- A) Mitosis
- B) Interphase
- C) Meiosis
- D) Cell Cycle

Q.197 Luteinizing hormone triggers

- A) Cessation of Oogenesis
- B) Breakdown of Oocyte
- C) Ovulation
- D) Development of Zygote

Q.198 Syphilis is a sexually transmitted disease which is caused by

- A) HIV / AIDS
- B) Pseudomonas Pyogenes
- C) Treponema Pallidum
- D) Neisseria

Q.199 Muscle is made up of many cells which are referred to as

- A) Myofilaments
- B) Myofibrils
- C) Sarcolemma
- D) Muscles Fiber

Q.200 The length of myofibril from one Z-band to the next is known as

- A) Sarcomere
- B) Sarcolemma
- C) Sarcoplasm
- D) Muscle Fiber

Q.201 Calcium ions released during a muscle fiber contraction attach with

- A) Myosin
- B) Actin
- C) Tropomyosin
- D) Troponin

Q.202 A muscle condition resulting from the accumulation of lactic acid and ionic imbalance is:

- A) Tetany
- B) Muscle Fatigue
- C) Cramp
- D) Tetanus

Q.203 The pigment which stores oxygen in muscles is

- A) Hemoglobin
- B) Myoglobin
- C) Myosin
- D) Actinomyosin

Q.204 Neurosecretory cells are present in which part of brain

- A) Hypothalamus
- B) Midbrain
- C) Pons
- D) Cerebellum

Q.205 Which of the following is the function of glucagon hormone?

- A) Glycogen to Glucose
- B) Glucose to Glycogen
- C) Glucose to Lipids
- D) Glucose to Proteins

Q.206 Addison's disease is caused due to destruction of

- A) Adrenal Cortex
- B) Pituitary Adrenal Axis
- C) Adrenal Medulla
- D) Hypothalamus

Q.207 Which group of hormones is made up of amino acids and their derivatives?

- A) Vasopressin and ADH
- B) Epinephrine and Non-Epinephrine
- C) Oestrogen and Testosterone
- D) Insulin and Glucagon

- Q.208 Thymus gland is involved in maturation of**
 A) Platelets
 B) B-Lymphocytes
 C) Eosinophils
 D) T-Lymphocytes
- Q.209 In passive immunity which of the following component are injected into blood**
 A) Antigens
 B) Immunogens
 C) Serum
 D) Immunoglobulins
- Q.210 Mucous membranes are part of body defense system and they offer**
 A) Physical Barriers
 B) Mechanical Barriers
 C) Chemical Barriers
 D) Biological Barriers
- Q.211 Immediate protection is obtained from**
 A) Passive Immunity
 B) Active Immunity
 C) Vaccination
 D) Natural Activity Immunity
- Q.212 The immunity in which T-cells recognize the antigens or micro-organisms is known as**
 A) Tissue Grafting
 B) Phagocytosis
 C) Cell Mediated Immunity / Response
 D) Hormonal Immunity / Response
- Q.213 Oxidative phosphorylation, synthesis of ATP in the presence of oxygen occurs in:**
 A) All Types of Cells
 B) All Anaerobic Cells
 C) All Primitive Cells
 D) All Aerobic Cells
- Q.214 Glycolysis is the breakdown of glucose into two molecules of**
 A) Glycerate
 B) Lactic Acid
 C) Pyruvate
 D) Succinic Acid
- Q.215 Before entering Krebs's cycle, the pyruvate is first decarboxylated and oxidized into**
 A) Alpha Ketoglutaric Acid
 B) Citric Acid
 C) Glyceric Acid
 D) Acetic Acid
- Q.216 Some electron from the second primary acceptor may pass back to chlorophyll molecules by electron carrier system, yielding ATP. This process is called**
 A) Phosphorylation
 B) Photophosphorylation
 C) Non-Cyclic Phosphorylation
 D) Cyclic Phosphorylation
- Q.217 Z-scheme is used for**
 A) Non-Cyclic Photophosphorylation
 B) Cyclic Photophosphorylation
 C) Both Cyclic and Non-Cyclic Photophosphorylation
 D) Oxidative Phosphorylation
- Q.218 The common vectors used in recombinant DNA technology are**
 A) Probes
 B) Palindromes
 C) Plasmids
 D) Prions
- Q.219 The enzyme used to isolate gene from DNA is**
 A) Helicase
 B) Reverse Transcriptase
 C) Restriction Enzyme
 D) DNA Polymerase
- Q.220 Which one of the following enzymes is temperature insensitive?**
 A) DNA Polymerase I
 B) Taq Polymerase
 C) DNA Polymerase III
 D) RNA Polymerase

MBBS.COM.PK

UHS MDCAT PAST PAPERS
BOOK Hard Copy Available
Now.

MBBS.COM.PK
EDUCATION SYSTEM

MDCAT GUIDE
UHS ENTRY TEST

MDCAT

PAST PAPER 2008-2019

- UNIT-WISE SOLVED MCQ's
- HIGHLIGHT REPEATED MCQ's
- CHANGING THE WAY YOU THINK
- BEST SOURCE TO GET HIGH MARKS
- UPDATED EDITION 2020
- AS PER UHS SYLLABUS

START
ENTRY TEST
PREPARATION
2020

LIVE CHAT
0304-7418334

Rs. 1400/=

Free Home Delivery

TO Book Order For MDCAT Past Papers
Call Or WhatsApp **0304-7418334**

University of Health Sciences, Lahore



Total MCQs: 220

Max. Marks: 1100

ENTRANCE TEST - 2012

For F.Sc. and Non-F.Sc. Students
Time Allowed: 150 minutes

Instructions:

- Read the instructions on the MCQs Response Form carefully.
- Choose the **Single Best Answer** for each question.
- Candidates are strictly prohibited from giving any identification mark except Roll No. & Signature in the specified columns only.

COMPULSORY QUESTION FOR IDENTIFICATION

Q-ID. What is the color of your Question Paper?

A) White.

C) Pink.

B)

Blue.

D) Green.

ID

Ans: Colour of your Question Paper is Blue.
Fill the Circle Corresponding to Letter 'B'
against 'ID' in your MCQ response form
(Exactly as shown in the diagram).

	A	B	C	D
	<input type="radio"/>	<input checked="" type="radio"/>	<input type="radio"/>	<input type="radio"/>
1	<input type="radio"/>	<input type="radio"/>	<input type="radio"/>	<input type="radio"/>
2	<input type="radio"/>	<input type="radio"/>	<input type="radio"/>	<input type="radio"/>
3	<input type="radio"/>	<input type="radio"/>	<input type="radio"/>	<input type="radio"/>
4	<input type="radio"/>	<input type="radio"/>	<input type="radio"/>	<input type="radio"/>

PHYSICS

Q.1 The diagram shows a small magnet hanging on a thread near the end of a solenoid carrying a steady current 'I':

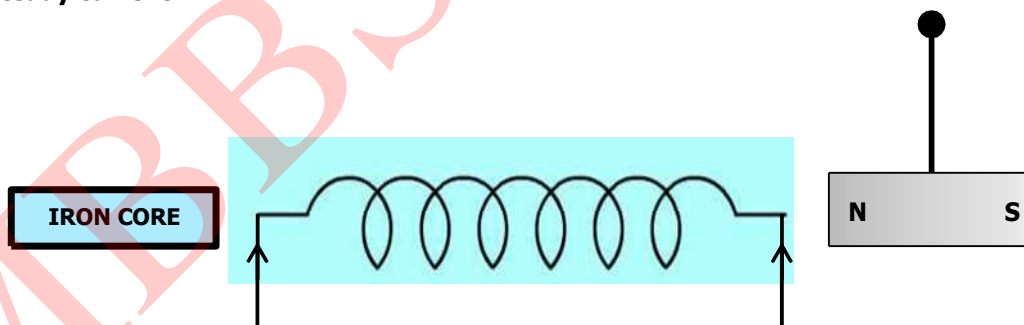

What happens to the magnet as the iron core is inserted into the solenoid?

- It moves towards solenoid and rotates through 180°
- It moves towards the solenoid
- It moves away from solenoid
- It moves away from solenoid and rotates through 180°

Q.2 A 10 cm long solenoid has 100 turns. What will be the magnetic field inside it along its axis if one micro ampere current is passed through it?

- $4\pi \times 10^{-13}$ tesla
- $4\pi \times 10^{-7}$ tesla
- $4\pi \times 10^{-10}$ tesla
- $4\pi \times 10^{-16}$ tesla

Q.3 Two long straight parallel wires held vertically have equal but opposite currents as shown in the figure.

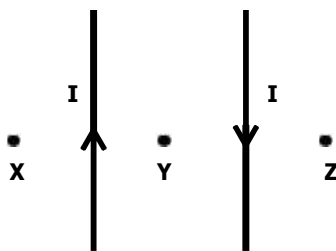

Which of the following effect will be observed?

- A) Magnetic field at 'X' is stronger than that at 'Y' and 'Z'
 B) Magnetic field at 'X' is weaker than that at 'Y' and 'Z'
 C) Magnetic field at 'X', 'Y' and 'Z' is same
 D) Magnetic field at 'X' is weaker than that at 'Y' but stronger than that at 'Z'.
- Q.4** The kinetic energy K.E. with which the electron strikes the target is given by:
 A) K.E. = e^2V
 B) K.E. = hc/λ
 C) K.E. = hf^2
 D) K.E. = eV
- Q.5** LASER is an acronym for:
 A) Light amplification by stimulated emission of radiation
 B) Light annihilation by stimulated emission of radiation
 C) Light amplitude of stimulated emission of radiation
 D) Light amplification by stimulated emission of radio
- Q.6** X-rays can be produced by bombardment of _____ on target metal:
 A) Protons
 B) Electrons
 C) Neutrons
 D) Alpha particles
- Q.7** Laser light is monochromatic which means
 A) It consists of one ray of light
 B) It consists of one wavelength
 C) It consists of carbon monoxide gas
 D) It consists of photons having 1 eV energy
- Q.8** If an electron in the 'K' shell is removed and an electron from 'L' shell jumps to occupy the hole in the 'K' shell, it emits a photon of energy:
 A) $hf_{K\alpha} = E_L - E_K$
 B) $hc = E_L - E_K$
 C) $h/\lambda_{K\alpha} = E_L - E_K$
 D) $hf_{K\alpha} = E_K - E_L$
- Q.9** Which of the following property must be there in a substance so that it can be used as target in X-ray tube?
 A) It must have low melting point
 B) It must have low atomic number
 C) It must have high reflecting ability
 D) It must have high atomic number
- Q.10** Which of the following can be used to produce population inversion for the emission of Laser?
 A) Optical pumping
 B) Optical fibre
 C) Optical instrument
 D) Optical polarization
- Q.11** What is the charge on alpha particles emitted during the phenomenon of radioactivity?
 A) $+e$
 B) $-e$
 C) $-2e$
 D) $+2e$
- Q.12** A radioactive nuclide decays by emitting an alpha particle, a beta particle and a gamma ray photon, the change in the nucleon number will be:
 A) -4
 B) -1
 C) -2
 D) -3
- Q.13** A half-life of sodium-24 is _____ which is used to estimate the volume of blood in a patient:
 A) 6 hours
 B) 15 hours
 C) 8 hours
 D) 15 days
- Q.14** Which of the following is unit of absorbed dose?
 A) Sievert
 B) Gray
 C) Roentgen
 D) Curie

- Q.15 In a radioactive phenomenon observation shown in figure where α deviates lesser than β in some electric or magnetic field (not shown in figure). What is the reason of less deviation of α ?

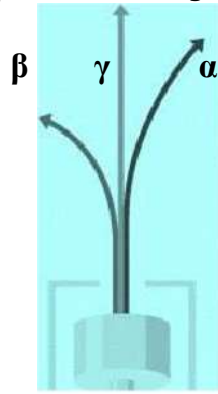

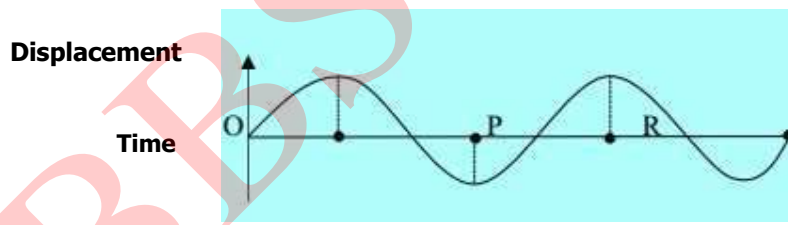

- A) α is charged particle
 C) α is heavier particle
 B) α is neutral particle
 D) α is lighter particle
- Q.16 The isotope of Iodine-131 is used in the treatment of
 A) Blood cancer
 C) Lung tumor
 B) Bone cancer
 D) Thyroid cancer
- Q.17 Which of the following effect is observed due to emission of β^- during the phenomenon of radioactivity?
 A) A increases by 1 and Z remains same
 C) Z decreases by 1 and A remains same
 B) Z increases by 1 and A remains same
 D) A decreases by 1 and Z remains same
- Q.18 Electric charge on an object is measured as 5 micro coulombs. How the value of this charge can be expressed in terms of base units:
 A) 5×100 ampere second
 C) $5 \times 10^{+6}$ coulomb second
 B) 5×10^{-6} ampere second
 D) 5×100 coulomb second
- Q.19 If 'm' is the mass, 'c' is the velocity of light and $x = mc^2$, then dimensions of 'x' will be:
 A) $[LT^{-1}]$
 C) $[MLT^{-1}]$
 B) $[ML^2T^{-2}]$
 D) $[MLT^{-2}]$
- Q.20 A force 'F' is acting at point 'P' of a uniform rod capable to rotate about 'O'. What is the torque about 'O'?
-
- A) $(OP)(F \tan \theta)$
 C) $(OP)(F \sin \theta)$
 B) $(OP)(F)$
 D) $(OP)(F \cos \theta)$
- Q.21 An object of mass 'm' is suspended in an elevator moving downward with acceleration equal to acceleration due to gravity. What is the apparent weight of object?
 A) Zero
 C) mg
 B) $2mg$
 D) $\frac{mg}{2}$
- Q.22 Stokes' Law for steady motion in a fluid of infinite extent is given by
 A) $F = 6\pi\eta rv$
 C) $F = 6\pi\eta r^2\rho$
 B) $F = (4/3)\pi r^3\rho g$
 D) $F = 2gr^2\rho/9\eta$
- Q.23 If speed of efflux through a small hole in a large tank is 9.8 m/s. Find the height at the fluid above the hole
 A) 1 m
 C) 4.9 m
 B) 9.8 m
 D) 19.6 m

- Q.24** Flow speed of the fluid through a non-uniform pipe increases from 1 m/sec to 3 m/sec. If change in P.E. is zero, then pressure difference between two points will be: (density of the fluid = 1000 kg/m³)
 A) 1000 N/m² C) 8000 N/m²
 B) 9000 N/m² D) 4000 N/m²
- Q.25** Polarization of light exhibited the nature of light as
 A) Longitudinal wave C) Transverse wave
 B) Compressional wave D) Electromagnetic wave
- Q.26** The concentration of a sugar solution can be determined by
 A) Un-polarized light C) Interference of light
 B) Plane polarized light D) Diffraction of light
- Q.27** The information from one place to another can be transmitted very safely and easily by:
 A) Copper wire C) Photodiode
 B) Aluminium wire D) Optical fibre
- Q.28** The image of an object placed inside the focal length of a convex lens will be largest and clearest when it is at the
 A) Less than 25 cm C) Greater than 25 cm
 B) Near point D) Infinity
- Q.29** A simple harmonic oscillator has a time period of 10 seconds. Which equation relates its acceleration 'a' and displacement 'x'?
 A) $a = -2x$ C) $a = -\left(\frac{2\pi^2}{10}\right)x$
 B) $a = -(20\pi)x$ D) $a = -(20\pi)^2x$
- Q.30** When the length of a simple pendulum is doubled, find the ratio of the new frequency to the old frequency?
 A) 1/4 C) $\sqrt{2}$
 B) 1/2 D) $1/\sqrt{2}$
- Q.31** In the diagram below, the displacement of an oscillating particle is plotted against time. What does the length 'PR' on the time axis represents?

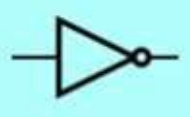
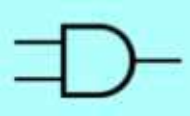

- A) Twice the frequency C) Half the frequency
 B) Half the period D) Twice the period
- Q.32** When the source of sound moves towards the stationary observer, the value of apparent frequency 'f_o' is:
 A) $f_o = \left(\frac{v+u_i}{v}\right) f$ C) $f_o = \left(\frac{v}{v+u_i}\right) f$
 B) $f_o = \left(\frac{v}{v-u_i}\right) f$ D) $f_o = \left(\frac{v-u_i}{v}\right) f$
- Q.33** The ratio of tensile strength to tensile strain is called
 A) Modulus of elasticity C) Young's Modulus
 B) Bulk Modulus D) Shear Modulus
- Q.34** A wire is stretched by a force 'F' which causes an extension Δl , the energy stored in the wire is:
 A) $F\Delta l$ C) $\frac{1}{2} F\Delta l^2$
 B) $2F\Delta l$ D) $\frac{1}{2} F\Delta l$

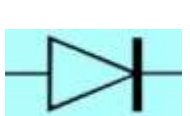
- Q.35** H_2 and O_2 both are at thermal equilibrium at temperature 300 K. Oxygen molecule is 16 times massive than hydrogen. Root mean square speed of hydrogen is
 A) 4 root mean square of oxygen
 B) $\frac{1}{4}$ root mean square of oxygen
 C) $\frac{1}{16}$ root mean square of oxygen
 D) $\frac{1}{6}$ root mean square of oxygen
- Q.36** Which of the following is expression of mean square speed of 'N' gas molecules contained in a cylinder?
 A) $\frac{v_1 + v_2 + \dots + v_x}{N}$
 B) $\frac{v_1^2 + v_2^2 + \dots + v_x^2}{N}$
 C) $\sqrt{\frac{v_1 + v_2 + \dots + v_x}{N}}$
 D) $\sqrt{\frac{v_1^2 + v_2^2 + \dots + v_x^2}{N}}$
- Q.37** If 'Q' is the amount of heat supplied to a system and 'W' is the work done, then change in internal energy can be defined as
 A) Q/W
 B) $Q - W$
 C) W/Q
 D) $1 + Q/W$
- Q.38** A heat engine operating according to second law of thermodynamics rejects one fourth of the heat taken from high temperature reservoir. What is the percentage efficiency of heat engine?
 A) 100%
 B) 25%
 C) 50%
 D) 75%
- Q.39** First law of thermodynamics under adiabatic conditions can be mathematically written as:
 A) $Q = W$
 B) $Q = \Delta U$
 C) $Q = U + W$
 D) $W = \Delta U$
- Q.40** What is the logic symbol for a NOT Gate?
 A) 
 B) 
 C) 
 D) 
- Q.41** The voltage that is applied across X-plates is provided by a circuit called
 A) Audio generator
 B) Time base generator
 C) Signal generator
 D) Linear generator
- Q.42** What will be the effect on the capacitance of a capacitor if area of each plate is doubled while separation between the plates is halved?
 A) Capacitance remains same
 B) Capacitance becomes double
 C) Capacitance becomes four times
 D) Capacitance reduces to half
- Q.43** 10 V potential difference is applied across the plate of 1 μF capacitor. What is the energy stored in capacitor?
 A) 0.5 mJ
 B) 0.05 mJ
 C) 5 mJ
 D) 50 mJ

- Q.44** Which one of the following is I-V curve of a junction diode?

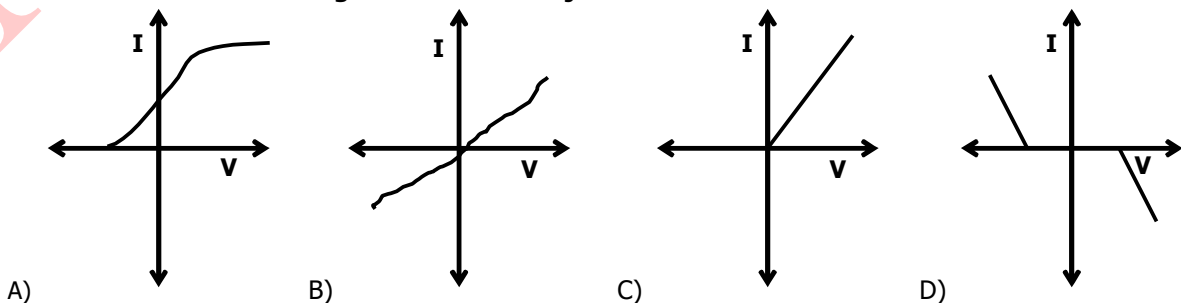

CHEMISTRY

Q.45 In the below reaction the nucleophile which attacks on the carbon atom of acid is:



- A) OH-
B) P

- C) Cl-
D) H-

Q.46 When ethanol chloride reacts with methylamine, an amide is formed. What is the structure of the amide formed?

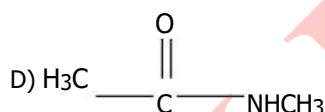
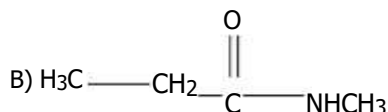
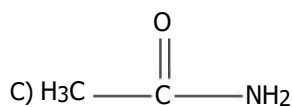
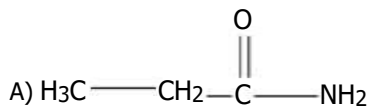

Q.47 Organic compound containing both amine and carboxyl group is known as

- A) Amino acid
B) Fatty acid

- C) Saccharide
D) Amide

Q.48 Alanine is an amino acid which shows neutral effect on litmus paper, the formula of alanine may be

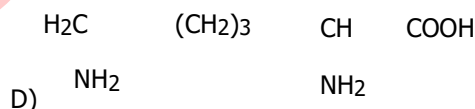
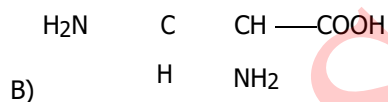
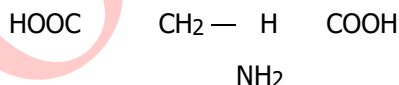
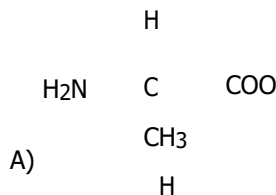

Q.49 Which of the following structures is not an alpha amino acid?

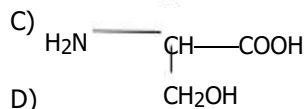
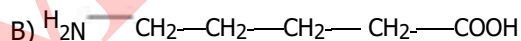
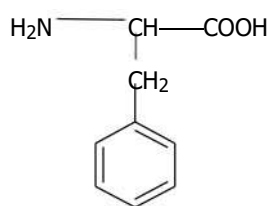
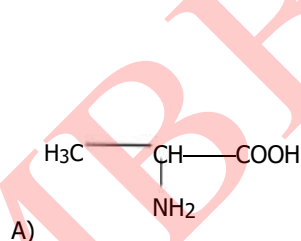

Q.50 The skeletal formula of dipeptide formed between aspartic acid and phenylalanine is given below:

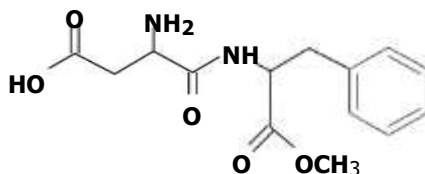

How many functional groups are present in its formula?

- A) 1
B) 2

- C) 4
D) 3

- Q.64 Correct order of boiling points of the given liquid is**
 A) $\text{H}_2\text{O} > \text{HF} > \text{HCl} > \text{NH}_3$
 B) $\text{HF} > \text{H}_2\text{O} > \text{HCl} > \text{NH}_3$
 C) $\text{H}_2\text{O} > \text{HF} > \text{NH}_3 > \text{HCl}$
 D) $\text{HF} > \text{H}_2\text{O} > \text{NH}_3 > \text{HCl}$
- Q.65 The relative energies of 4s, 4p and 3d orbitals are in the order**
 A) $3d < 4p < 4s$
 B) $4s < 3d < 4p$
 C) $4p < 4s < 3d$
 D) $4p < 3d < 4s$
- Q.66 With increase in the value of Principal Quantum Number 'n', the shape of the s-orbitals remains the same although their sizes**
 A) Decrease
 B) Increase
 C) Remain the same
 D) May or may not remain the same
- Q.67 The angle between unhybridized p-orbital and three sp^2 hybrid orbitals of each carbon atom in ether is:**
 A) 120°
 B) 90°
 C) 109.5°
 D) 180°
- Q.68 In 'H-F' bond electronegativity difference is '1.9'. What is the type of this bond?**
 A) Polar covalent bond
 B) Non-polar covalent bond
 C) Pi (π) bond
 D) Co-ordinate covalent bond
- Q.69 ' ΔH ' will be given a negative sign in**
 A) Exothermic reactions
 B) Decomposition reactions
 C) Dissociation reaction
 D) Endothermic reactions
- Q.70 Lattice energy of an ionic crystal is the enthalpy of**
 A) Combustion
 B) Dissociation
 C) Dissolution
 D) Formation
- Q.71 As number of solute particles increases, freezing point of the solution:**
 A) Remains the same
 B) Increases
 C) First increases, then decreases
 D) Decreases
- Q.72 Boiling point constants help us to determine**
 A) Molar masses
 B) Volumes
 C) Pressures
 D) Masses
- Q.73 In electrolysis of aqueous CuCl_2 , the metal deposited at cathode is**
 A) Sodium
 B) Aluminium
 C) Lead
 D) Copper
- Q.74 In MgCl_2 , the oxidation state of 'Cl' is**
 A) Zero
 B) +2
 C) -2
 D) -1
- Q.75 Formation of NH_3 is reversible and exothermic process, what will happen on cooling?**
 A) More reactant will form
 B) More N_2 will be formed
 C) More H_2 will be formed
 D) More product (NH_3) will be formed
- Q.76 A buffer solution is that which resists/minimizes the change in**
 A) pOH
 B) pH
 C) pKa
 D) pKb
- Q.77 In some reactions, a product formed acts as a catalyst. The phenomenon is called**
 A) Negative Catalysis
 B) Activation of Catalyst
 C) Heterogeneous catalysis
 D) Autocatalysis
- Q.78 The reaction rate in forward direction decreases with the passage of time because**
 A) Concentration of reactants decrease
 B) Concentration of product decreases
 C) The order of reaction changes
 D) Temperature of the system changes

- Q.79 Which one remains same along a period?**
 A) Atomic radius
 B) Melting point
 C) Number of shells (orbits)
 D) Electrical conductivity
- Q.80 More the ionization energy of an element:**
 A) More the electropositivity
 B) More the reducing power
 C) Less the metallic character
 D) Bigger the atomic radius
- Q.81 Alkaline earth metal hydroxides decompose on heating. Which of the following reactions is a correct representation of this decomposition?**
 A) $M(OH)_{2(s)} \longrightarrow MO_{(s)} + H_2O_{(l)}$
 B) $MOH_{(s)} \longrightarrow M_2O_{(s)} + H_2O_{(l)}$
 C) $2MOH_{2(s)} \longrightarrow 2MO_{(s)} + H_2_{(l)}$
 D) $4MOH_{(s)} \longrightarrow 4M_{(s)} + 2H_2O_{(l)} + O_2$
- Q.82 Carbon has the unique ability to form long chains by bonding with other carbon atoms. This property of self-linking in carbon is known as:**
 A) Condensation
 B) Polymerization
 C) Cyclization
 D) Catenation
- Q.83 Oxidation state of 'Mn' in $KMnO_4$, K_2MnO_4 , MnO_2 and $MnSO_4$ is in the order:**
 A) +7, +6, +2, +4
 B) +6, +7, +2, +4
 C) +7, +6, +4, +2
 D) +4, +6, +7, +2
- Q.84 Which pair of transition elements shows abnormal electronic configuration?**
 A) Sc and Zn
 B) Cu and Sc
 C) Zn and Cu
 D) Cu and Cr
- Q.85 The acid rain water has pH:**
 A) Below 5
 B) 7
 C) Between 5 and 7
 D) Between 7 and 14
- Q.86 In Contact Process for manufacturing sulphuric acid, Sulphur trioxide (SO_3) is not absorbed in water because**
 A) The reaction does not go to completion
 B) The reaction is highly exothermic
 C) The reaction is quite slow
 D) SO_3 is insoluble in water
- Q.87 In modern Haber Process Plants, the temperature maintained during the process is**
 A) 670 - 770 K (400 °C - 500 °C)
 B) 270 - 370 K (0 °C - 100 °C)
 C) 370 - 470 K (100 °C - 200 °C)
 D) 570 - 600 K (300 °C - 380 °C)
- Q.88 In the Haber process for manufacturing of ammonia, Nitrogen is taken from**
 A) Proteins occurring in living bodies
 B) Ammonium salts obtained industrially
 C) Air
 D) Minerals containing nitrates
- Q.89 Ethene on polymerization, gives the product polyethene. This reaction may be called as**
 A) Addition
 B) Condensation
 C) Substitution
 D) Pyrolysis
- Q.90 In the following, which one is free radical?**
 A) Cl^-
 B) Cl^+
 C) Cl_2
 D) Cl^\bullet
- Q.91 The introduction of $R-\overset{\overset{O}{||}}{C}-$ group in benzene is called**
 A) Acylation
 B) Carbonyl reduction
 C) Alkylation
 D) Formylation
- Q.92 The alkaline hydrolysis of bromoethane shown below gives alcohol as the product:**

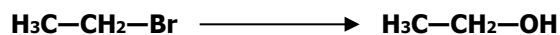

The reagent and the condition used in this reaction may be:

- A) H_2O at room temperature
 B) Ethanol, heat
 C) KOH in alcohol
 D) Dilute $NaOH_{(aq)}$ warm

Q.93 In the reaction of ethane with bromine the intermediate formed is

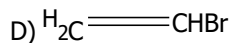
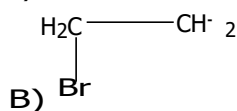
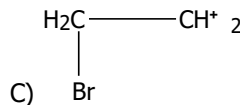
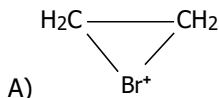

Q.94 In substitution reactions, dihaloalkane or secondary halogenoalkane give / show:

- A) S_N1 Mechanism
B) S_N2 Mechanism

- C) Both E_1 and E_2
D) Both S_N1 and S_N2

Q.95 The dehydration of ethyl alcohol with concentrated H_2SO_4 at $140^\circ C$ gives:

- A) Ethene
B) Diethyl ether

- C) Alcohol
D) Carboxylic acid

Q.96 Ethanol can be converted in to ethanoic acid by:

- A) Oxidation
B) Fermentation

- C) Hydration
D) Hydrogenation

Q.97 The following structure is of:

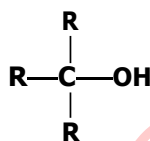

- A) Secondary alcohol
B) Primary alcohol

- C) Tertiary alcohol
D) Carboxylic acid

Q.98 When ethanol is warmed with ethanoic acid in the presence of strong acid catalyst, an ester ethyl ethanoate is formed.



During this reaction:

- A) Alcohol is reduced
B) O-H bond in ethanoic acid is broken

- C) O-H bond in ethanol is broken
D) Acid is oxidized

Q.99 Primary alcohols normally give us aldehydes when oxidized in the presence of $Na_2Cr_2O_7$, what the product will be, when the secondary alcohols are oxidized in same conditions?

- A) Alkenes
B) Alkynes

- C) Alkyl halides
D) Ketones

Q.100 Formaldehyde reacts with HCN (NaCN + HCl) to give a compound:

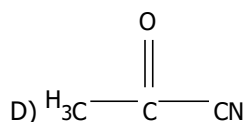
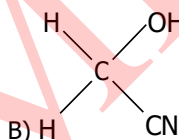
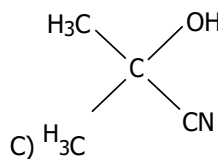
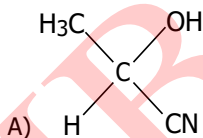

Q.101 Iodoform test will not be positive with:

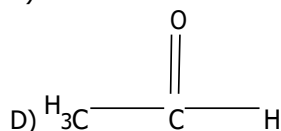
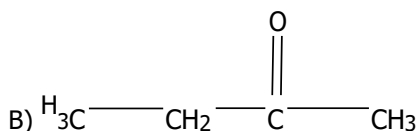
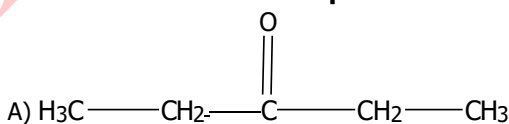

Q.102 When $\text{CH}_3\text{—CH}_2\text{—OH}$ is oxidized in the presence of $\text{K}_2\text{Cr}_2\text{O}_7$ and H_2SO_4 , the product formed is

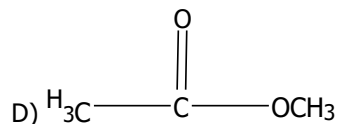
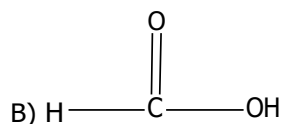
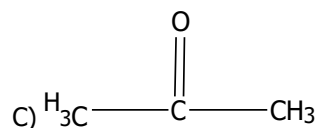
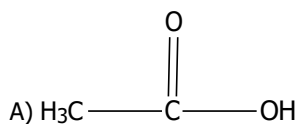

ENGLISH

Q.103 He had a heart attack and all attempts to _____ him failed.

- A) Renew
B) Resuscitate
C) Revise
D) Refurnish

Q.104 The _____ stench of dead animals and plants made Mumtaz ill.

- A) Putrid
B) Purified
C) Perturbed
D) Purchased

Q.105 While going up the hills, by bus, she felt _____ inside.

- A) Fishy
B) Itchy
C) Queasy
D) Squeezy

Q.106 The craft statesman manipulated the situation by making false promises and declaring sport festivities as a _____ to fool the public.

- A) Red-Hearing
B) Red-Feather
C) Red-Herring
D) Red-Haring

⇒ **SPOT THE ERROR:** In the following sentences, some segments of each sentence are underlined. Your task is to identify that underlined segment of the sentence, which contains the mistake that needs to be corrected. Fill the Circle corresponding to that letter under the segment in the MCQ Response Form.

Q.107 The theory was discarded as there was no corroborating evidence for its favour.

- A) B) C) D)

Q.108 The workers were raising much hue and cry when their demands were turned away.

- A) B) C) D)

Q.109 Aslam was badly cudged from his step-brother. He received many bruises and contusions. Thank God! No

injury was serious.

- A) B) C) D)

Q.110 I extend a cordial invitation for you to visit our farm house. We have grown vegetables without chemical

fertilizers over there.

- A) B) C) D)

Q.111 Although he is not a close relative of me, yet I was greeted with a show of deep cordiality.

- A) B) C) D)

Q.112 This antibiotic destroys red corpuscles in the blood and cause pernicious anaemia.

- A) B) C) D)

⇒ In each of the following question, four alternative sentences are given. Choose the **CORRECT** one and fill the Circle corresponding to that letter in the MCQ Response Form.

Q.113

- A) Why does not Nomana remained true to her husband?
- B) Why did not Nomana remain true to her husband?
- C) Why had not Nomana remain true to her husband?
- D) Why did not Nomana remained true to her husband?

Q.114

- A) All my childhood, I longed desperately in for a tricycle.
- B) All my childhood, I longed desperately to a tricycle.
- C) All my childhood, I longed desperately for a tricycle.
- D) All my childhood, I longed desperately at a tricycle.

Q.115

- A) She felt unreal to the voice informed her of the subway accident.
- B) She felt unreal as the voice informed her of the subway accident.
- C) She felt unreal that the voice informed her of the subway accident.
- D) She felt unreal for the voice informed her of the subway accident.

Q.116

- A) Bill Gates is one of the wealthiest person in the world.
- B) Bill Gates is one of the wealthy person in the world.
- C) Bill Gates is one of the wealthiest persons in the world.
- D) Bill Gates is one of the more wealthy person in the world.

Q.117

- A) Her father is a SP in the Punjab Police.
- B) Her father was a SP in the Punjab Police.
- C) Her father is an SP in the Punjab Police.
- D) Her father are a SP in the Punjab Police.

Q.118

- A) There were musical instruments in the shop.
- B) There was musical instruments in the shop.
- C) There has musical instruments in the shop.
- D) There is musical instruments in the shop.

Q.119

- A) He died for heart attack in 1982.
- B) He died with heart attack in 1982.
- C) He died in heart attack in 1982.
- D) He died of heart attack in 1982.

Q.120

- A) Always speak in the truth.
- B) Always tell for the truth.
- C) Always tell the truth.
- D) Always telling truth.

Q.121

- A) Hand up the answer sheet to me.
- B) Hand over the answer sheet to me.
- C) Hand down the answer sheet to me.
- D) Hand for the answer sheet to me.

Q.122

- A) Are you noticed the peach blossoms?
- B) Have you noticed the peach blossoms?
- C) Will you noticed the peach blossoms?
- D) Were you noticed the peach blossoms?

⇒ In each of the following question, four alternative meanings of a word are given. You have to select the **NEAREST CORRECT MEANING** of the given word and fill the appropriate Circle on the MCQ Response Form.

Q.123 **DISSONANCE**

- A) Inconsistency
- B) Expansion
- C) Perceptible
- D) Warp

Q.124 **TRIFLE**

- A) Pudding
- B) Minor
- C) Deluge
- D) Treble

- Q.125 MURKY**
A) Dusty
B) Squeamy
C) Clear
D) Unclear
- Q.126 FAUX**
A) Blunder
B) Mistake
C) Indiscretion
D) False
- Q.127 MYRIAD**
A) Countable
B) Multitude
C) Measured
D) Blurred
- Q.128 FACILE**
A) Fallacy
B) Depict
C) Delicate
D) Superficial
- Q.129 MAGNUM**
A) Masterpiece
B) Magnanimity
C) Modest
D) Magnetic
- Q.130 SIDLE**
A) Sneak
B) Sift
C) Siege
D) Sieve
- Q.131 PLETHORA**
A) Plastic
B) Super-fluidity
C) Measure
D) Malleable
- Q.132 VERTEX**
A) Poetry
B) Depth
C) Zenith
D) Diminish

BIOLOGY

- Q.133 The part of neuron fibre which conducts nerve impulses from the cell body is**
A) Dendron
B) Dendrites
C) Axon
D) Peripheral branch
- Q.134 The number of cranial nerves in human is**
A) 31 pairs
B) 12 pairs
C) 24 pairs
D) 62 pairs
- Q.135 The part of brain which controls breathing, heart rate and swallowing is**
A) Cerebrum
B) Cerebellum
C) Medulla
D) Hypothalamus
- Q.136 Syphilis is a sexually transmitted disease which is caused by**
A) Neisseria gonorrhoeae
B) E. coli
C) Treponema pallidum
D) Mycobacterium avium
- Q.137 Discharge of ovum or secondary oocyte from ovary or from Graafian follicle is called**
A) Fertilization
B) Pollination
C) Follicle formation
D) Ovulation
- Q.138 Second meiotic division in the secondary oocyte proceeds as far as**
A) Metaphase
B) Prophase
C) Anaphase
D) Telophase
- Q.139 Which one of the following differentiates directly into mature sperm?**
A) Primary spermatocyte
B) Secondary spermatocyte
C) Spermatogonia
D) Spermatid

Q.140 Uterus opens into the vagina through

- A) Cervix
- B) Fallopian tube
- C) External genitalia
- D) Vulva

Q.141 Each muscle fibre is surrounded by membrane which is called

- A) Sarcomere
- B) Sarcolemma
- C) Twitch fibre
- D) Capsule

Q.142 When calcium ions are released from the sarcoplasmic reticulum they bind with _____ during muscle contraction

- A) Tropomyosin
- B) Sarcolemma
- C) Cytosol's ions
- D) Troponin

Q.143 Human and mammalian skeleton can be divided into two parts, axial skeleton and

- A) Appendicular skeleton
- B) Exoskeleton
- C) Endoskeleton
- D) Hydrostatic skeleton

Q.144 Last four vertebrae in humans are fused to form a structure called

- A) Sacrum
- B) Cervical vertebrae
- C) Pubis
- D) Coccyx

Q.145 How many bones are involved in the formation of each half of pelvic girdle?

- A) 3 bones
- B) 4 bones
- C) 2 bones
- D) 1 bone

Q.146 Ductless glands are known as

- A) Endocrine gland
- B) Exocrine gland
- C) Salivary glands
- D) Bile glands

Q.147 Gastrin is the hormone which is produced by the

- A) Liver
- B) Pyloric region of stomach
- C) Adrenal gland
- D) Mucosal lining of intestine

Q.148 β -cells of liver secrete a hormone that is called

- A) Insulin
- B) Glucagon
- C) Antidiuretic hormone
- D) Gastrin

Q.149 Vasopressin and Oxytocin are released from the

- A) Placenta
- B) Ovary
- C) Anterior pituitary
- D) Posterior pituitary

Q.150 Antigen is a foreign protein or any other molecule which stimulates the formation of

- A) MHC complex
- B) Immunogen
- C) Mucus
- D) Antibodies

Q.151 Antibodies are produced by which of the following lymphocytes?

- A) B lymphocytes
- B) A lymphocytes
- C) T lymphocytes
- D) B and T lymphocytes

Q.152 T-lymphocytes become mature and competent under the influence of

- A) Liver
- B) Bursa of fabricius
- C) Thymus gland
- D) Spleen

Q.153 Skin and mucous membranes are part of the body defense system and they form the

- A) Physical barrier
- B) Mechanical barriers
- C) Chemical barriers
- D) Biological barriers

Q.154 Snake bite is treated with which type of immunization?

- A) Active
- B) Passive
- C) Humoral
- D) Specific

- Q.155 The product(s) of cyclic photophosphorylation is / are:**
 A) ATP
 B) NADP
 C) NADP and ATP
 D) NADP, ATP, and O₂
- Q.156 Total NADH formed by one glucose molecule during Krebs's Cycle are**
 A) 6
 B) 3
 C) 8
 D) 18
- Q.157 The terminal electron acceptor in electron transport chain is**
 A) Hydrogen
 B) Iron
 C) Cytochrome
 D) Oxygen
- Q.158 The end product of glycolysis is**
 A) ADP
 B) Reduced FAD
 C) Citric acid
 D) Pyruvate
- Q.159 One molecule of FADH₂ is produced in Krebs's cycle during conversion of**
 A) Fumarate Malate
 B) Succinate Fumarate
 C) Malate Oxaloacetate
 D) α-Ketoglutarate Succinate
- Q.160 In recombinant DNA technology _____ are tools for manipulating DNA**
 A) Viruses
 B) Chromosomes
 C) Enzymes
 D) Genes
- Q.161 In DNA finger printing process, the use of _____ produces distinctive pattern on autoradiography or X-ray film**
 A) Restriction enzyme
 B) Microsatellites
 C) Macrosatellites
 D) Probes for genetic markers
- Q.162 In the recombinant DNA technology plasmids are used as**
 A) Genetic material
 B) Enzymes
 C) Vectors
 D) Probes
- Q.163 In which process, multiple copies of the desired genes are produced?**
 A) Polymerase chain reaction
 B) Gene sequencing
 C) Analyzing DNA
 D) DNA finger printing
- Q.164 The enzyme adenosine deaminase is missing in person suffering from:**
 A) Cystic fibrosis
 B) Hypercholesterolemia
 C) Severe combined immunodeficiency syndrome
 D) Parkinson's disease
- Q.165 What is the niche of an organism in an ecosystem?**
 A) Role played by many organisms in an ecosystem
 B) Role played by a dead organism in an ecosystem
 C) Role played by community of microorganisms in their ecosystem
 D) Role played by an organism in its ecosystem.
- Q.166 The distinct levels or links of food chain are called**
 A) Trophic level
 B) Food web
 C) Energy pyramid
 D) Food chain
- Q.167 A relationship between two or more organisms of different species in which all partners get benefit is called**
 A) Symbiosis
 B) Parasitism
 C) Commensalism
 D) Predation
- Q.168 Bacteria and fungi are examples of**
 A) Producers
 B) Decomposers
 C) Consumers
 D) Denvers
- Q.169 The cause of acid rain is**
 A) Oxides of carbon
 B) Oxides of nitrogen and Sulphur
 C) Oxides of Sulphur
 D) Oxides of nitrogen

- Q.170 When the presence of a gene at one locus suppresses the effect of a gene at another locus, the phenomenon is called**
A) Hypostasis
B) Pleiotropy
C) Epistasis
D) Epitropy
- Q.171 The gene for ABO-blood group systems in humans is represented by symbol:**
A) X
B) I
C) Y
D) O
- Q.172 When a single gene affects two or more traits, the phenomenon is called**
A) Epistasis
B) Pleiotropy
C) Dominance
D) Over dominance
- Q.173 The comparative embryology of all vertebrates shows development of**
A) Hairs
B) Gill pouches
C) Scales
D) Fins
- Q.174 In men, sex-determination depends upon the nature of**
A) Heterogametic male
B) Homogametic female
C) Heterogametic female
D) Homogametic male
- Q.175 Population of different species (plants and animals) living in the same habitat form a**
A) Community
B) Ecosystem
C) Biosphere
D) Microhabitat
- Q.176 The part of the body which forms a structural and functional unit and is composed of more than one tissue is called**
A) Organ
B) Organelle
C) Organ system
D) Whole organism
- Q.177 A method in which pests are destroyed by using same living organisms or natural enemies is called**
A) Pasteurization
B) Integrated disease management
C) Biological control
D) Genetic engineering
- Q.178 Chemicals produced by microorganisms which are capable of destroying the growth of microbes are called**
A) Antigen
B) Biocidal
C) Antiseptics
D) Antibiotics
- Q.179 Plastids are only found in the**
A) Animals and Plants
B) Animals
C) Plants
D) Viruses
- Q.180 Plasma membrane is chemically composed of**
A) Phospholipids only
B) Lipids and proteins
C) Lipids and carbohydrates
D) Glycoproteins
- Q.181 Endoplasmic reticulum contains a system of flattened membrane-bounded sacs which are named as**
A) Cristae
B) Marks
C) Cisternae
D) Tubules
- Q.182 Lipids synthesis / metabolism takes place in which of the following organelle?**
A) Mitochondria
B) Vacuoles
C) Rough endoplasmic reticulum
D) Smooth endoplasmic reticulum
- Q.183 Ribosomes exist in two forms, either attached with RER or freely dispersed in the**
A) Tonoplast
B) Golgi bodies
C) Cytoplasm
D) SER

- Q.184 Exchange of segments between homologous chromosomes is called**
 A) Segregation
 B) Independent assortment
 C) Crossing over
 D) Mutation
- Q.185 If a person has 44 autosomes + XXY, he will suffer from**
 A) Klinefelter's syndrome
 B) Down's syndrome
 C) Turner's syndrome
 D) Edward's syndrome
- Q.186 The ribosomal RNA is synthesized and stored in**
 A) Endoplasmic reticulum
 B) Nucleolus
 C) Golgi complex
 D) Chromosomes
- Q.187 In which stage of Interphase, there is increase in cell size and many biochemical are formed?**
 A) G₂ phase
 B) G₁ phase
 C) S phase
 D) C phase
- Q.188 In Down's syndrome, which one of the following pair of chromosome fails to segregate?**
 A) 7
 B) 18
 C) 21
 D) 19
- Q.189 Carbohydrates are organic molecules and contain three elements**
 A) Carbon, water and oxygen
 B) Carbon, Sulphur and hydrogen
 C) Carbon, calcium and hydrogen
 D) Carbon, hydrogen and oxygen
- Q.190 Which one are intermediates in respiration and photosynthesis both?**
 A) Ribose and heptolose
 B) Glyceraldehydes and dihydroxyacetone
 C) Glucose and galactose
 D) Fructose and ribulose
- Q.191 Which of the following is a peptide bond?**
 A) -C-N
 B) -C-O
 C) -C-P
 D) -C-S
- Q.192 Which of the following is an unsaturated fatty acid?**
 A) Acetic Acid
 B) Butyric acid
 C) Oleic acid
 D) Palmitic acid
- Q.193 Which of the following combination of base pair is absent in DNA?**
 A) A-T
 B) C-G
 C) A-U
 D) T-A
- Q.194 The type of inhibition in which inhibitor has no structural similarity to substrate and combines with enzyme at other than the active site is called**
 A) Irreversible inhibition
 B) Competitive inhibition
 C) Non-competitive and reversible inhibition
 D) Reversible inhibition
- Q.195 The inhibitors that bind tightly and permanently to enzymes and destroy their globular structure and catalytic activity are**
 A) Reversible inhibitors
 B) Irreversible inhibitors
 C) Competitive inhibitors
 D) Non-competitive inhibitors
- Q.196 Enzyme succinate dehydrogenase converts succinate into**
 A) Malate
 B) Malonic acid
 C) Citrate
 D) Fumarate
- Q.197 If the detachable co-factor is an inorganic ion then it is designated as**
 A) Coenzyme
 B) Prosthetic group
 C) Holoenzyme
 D) Activator
- Q.198 In HIV viruses, reverse transcriptase converts single-stranded RNA into double stranded viral DNA. This process is called**
 A) Translation
 B) Duplication
 C) Replication
 D) Reverse Transcriptase

- Q.199 Mesosomes are infoldings of the cell membrane and are involved in**
A) DNA replication
B) RNA synthesis
C) Protein synthesis
D) Metabolism
- Q.200 Most widespread problem of the antibiotics misuse is the**
A) Rapid cure
B) Increased resistance in pathogen
C) Disturbance of metabolism
D) Immunity
- Q.201 Which of the following component is found in the cell wall of fungi?**
A) Cellulose
B) Chitin
C) Proteins
D) Glycerol
- Q.202 The male reproductive parts of the flower are called**
A) Gynoecium
B) Calyx
C) Androecium
D) Corolla
- Q.203 Fasciola is the name given to**
A) Tapeworm
B) Planaria
C) Liver fluke
D) Earthworm
- Q.204 Ascaris is**
A) Diploblastic
B) Triploblastic
C) Haploid
D) Acoelomate
- Q.205 During development, in an animal, mesoderm layer gives rise to**
A) Nervous System
B) Alimentary canal lining
C) Muscular and skeletal system
D) Mouth
- Q.206 Polymorphism is characteristic feature of**
A) Porifera
B) Cnidaria
C) Annelida
D) Nematodes
- Q.207 The muscles of the stomach walls thoroughly mix up the food with gastric juices and the resulting semi-solid / semi-liquid material is called**
A) Bolus
B) Bolus or chyme
C) Mucus
- Q.208 Trypsinogen is secreted by**
A) Goblet cells
B) Absorptive cells
- Q.209 In large intestine**
A) Symbiotic bacteria
B) Obligate anaerobes
- Q.210 Goblet cells secrete**
A) HCl
B) Mucus
- Q.211 Mature mammalian red blood cells do not have**
A) Nucleus
B) Red color
C) Fluids
D) Haemoglobin
- Q.212 In a normal person plasma constitutes about _____ by volume of blood**
A) 50%
B) 60%
C) 45%
D) 55%
- Q.213 Which vein has oxygenated blood?**
A) Renal vein
B) Subclavian vein
C) Pulmonary vein
D) Jugular vein

IMPORTANT

Unit Wise MDCAT Past Papers
Book is Very Important for the
Preparation. This Book
Available only online With
Free Home Delivery.

Q.214 What is the residual volume of air which always remains inside the lungs of human?

- A) 3.5 Liters
- B) 0.5 Liters
- C) 5.0 Liters
- D) 1.5 Liters

Q.215 In nephron, most of the reabsorption takes place in the

- A) Distal tubule
- B) Proximal tubule
- C) Ascending limb
- D) Descending limb

Q.216 Detection of change and signaling for effector's response to the control system is a

- A) Negative feedback
- B) Positive feedback
- C) Inter-coordination
- D) Feedback mechanism

Q.217 What are three components of mechanism of homeostatic regulations?

- A) Receptors, control centre and effectors
- B) Sensory, motor and associative neurons
- C) CNS, PNS and diffused nervous system
- D) Cerebrum, cerebellum and pons

Q.218 Blood enters the glomerulus through

- A) Efferent arteriole
- B) Afferent arteriole
- C) Renal artery
- D) Renal vein

Q.219 Which portion of nephron is under the control of ADH?

- A) Bowman's capsule
- B) Ascending arm
- C) Distal and collecting ducts
- D) Descending arm

Q.220 Cause of Parkinson's disease is death of brain cells that produce

- A) Dopamine
 - B) Acetylcholine
 - C) ADH hormone
 - D) Oxytocin
-

MBBS.COM.PK

UHS MDCAT PAST PAPERS
BOOK Hard Copy Available
Now.

MBBS.COM.PK
EDUCATION SYSTEM

MDCAT GUIDE
UHS ENTRY TEST

MDCAT

PAST PAPER 2008-2019

- UNIT-WISE SOLVED MCQ's
- HIGHLIGHT REPEATED MCQ's
- CHANGING THE WAY YOU THINK
- BEST SOURCE TO GET HIGH MARKS
- UPDATED EDITION 2020
- AS PER UHS SYLLABUS

START
ENTRY TEST
PREPARATION
2020

LIVE CHAT
0304-7418334

Rs. 1400/=

Free Home Delivery

TO Book Order For MDCAT Past Papers
Call Or WhatsApp 0304-7418334

University of Health Sciences, Lahore



Total MCQs: 220

Max. Marks: 1100

ENTRANCE TEST - 2013 For F.Sc. and Non-F.Sc. Students Time Allowed: 150 minutes

Instructions:

- Read the instructions on the MCQs Response Form carefully.
- Choose the **Single Best Answer** for each question.
- Candidates are strictly prohibited from giving any identification mark except Roll No. & Signature in the specified columns only.

COMPULSORY QUESTION FOR IDENTIFICATION

Q-ID. What is the color of your Question Paper?

A) White. C) Pink.

B) Blue. D) Green. ID

Ans: Colour of your Question Paper is Pink.
Fill the Circle Corresponding to Letter 'C'
against 'ID' in your MCQ response form
(Exactly as shown in the diagram).

	A	B	C	D
1	<input type="radio"/>	<input type="radio"/>	<input checked="" type="radio"/>	<input type="radio"/>
2	<input type="radio"/>	<input type="radio"/>	<input type="radio"/>	<input type="radio"/>
3	<input type="radio"/>	<input type="radio"/>	<input type="radio"/>	<input type="radio"/>
4	<input type="radio"/>	<input type="radio"/>	<input type="radio"/>	<input type="radio"/>

PHYSICS

- Q.1** The wavelength ' λ ' of a wave depends on the speed ' v ' of the wave and its frequency ' f '. Decide which of the following is correct?
- A) $f = v \lambda$ C) $f = \frac{v}{\lambda}$
- B) $f = \frac{\lambda}{v}$ D) $f = v \lambda^2$
- Q.2** Name the quantity which can be measured by using base unit ' $\text{kgm}^2\text{s}^{-3}$ '
- A) Weight C) Power
- B) Pressure D) Work
- Q.3** Ratio of moment of inertia of two objects 'A' and 'B' is 2:3. Which one of the following is the ratio of torques of 'A' and 'B' respectively, if both are being rotated with constant angular acceleration?
- A) 3:4 C) 3:2
- B) 2:3 D) 4:3
- Q.4** Due to some mechanical fault, a lift falls freely from the top of a multistory building. Which of the followings is the apparent weight of a man inside the lift, if mass of man is 80 kg while value of ' g ' is 10 ms^{-2} ?
- A) 900 N C) 800 N
- B) Zero D) 700 N
- Q.5** Stokes' Law is given as:
- A) $F = 6\pi\eta r^2v$ C) $F = 6\pi\eta r v^{-1}$
- B) $F = 6\pi\eta r v$ D) $F = 6\pi^2\eta r^3v$

- Q.6 The product of cross-sectional area of the pipe and the fluid speed at any point along the pipe:**
 A) Remains constant C) Exponentially increases
 B) Is zero D) Exponentially decreases
- Q.7 A small leak is developed in a large water storage tank. If the height of water above leakage is 10 m, then find the speed of efflux through the leak:**
 A) 14 m/sec C) 9.8 m/sec
 B) 10 m/sec D) 20 m/sec
- Q.8 The minimum distance from the eye at which an object can be seen clearly without strain is called:**
 A) Focal point C) Yield point
 B) Near point D) Far point
- Q.9 In the diffraction of light around an obstacle, the angle of diffraction is increased then:**
 A) The wavelength of incident light wave is increased C) The amplitude of the incident light wave is increased
 B) The wavelength of incident light wave is decreased D) The amplitude of the incident light wave is decreased
- Q.10 An object 15 cm from a lens produces a real image 30 cm from the lens. What is the focal length of the lens?**
 A) +15 cm C) +10 cm
 B) +20 cm D) +25 cm
- Q.11 What is the formula for critical angle in case of light through two mediums having refractive indexes n_1 and n_2 such that $n_1 > n_2$?**
 A) $\sin^{-1} \left(\frac{n_2}{n_1} \right)$ C) $\cos^{-1} \left(\frac{n_2}{n_1} \right)$
 B) $\cos^{-1} \left(\frac{n_1}{n_2} \right)$ D) $\sin^{-1} \left(\frac{n_1}{n_2} \right)$
- Q.12 For vibrating mass-spring system, the expression of kinetic energy at any displacement 'x' is given by:**
 A) $\frac{1}{2} kx_0^2 \left(1 - \frac{x^2}{x_0^2} \right)$ C) $\frac{1}{2} m\omega^2 \left(1 - \frac{x^2}{x_0^2} \right)$
 B) $\frac{1}{2} kx_0$ D) $\frac{1}{2} m\omega x_0$
- Q.13 Speed of sound through a gas is measured as 340 m/s at pressure P_1 and temperature T_1 . What will be the speed of sound if pressure of gas is doubled but temperature is kept constant?**
 A) 342 m/s C) 170 m/s
 B) 340 m/s D) 680 m/s
- Q.14 The stress-strain graph, deduced the following limits successively:**
 A) Proportional limit, yield limit, elastic limit C) Proportional limit, elastic limit, yield limit
 B) Yield limit, elastic limit, proportional limit D) Elastic limit, proportional limit, yield limit
- Q.15 Variation of amplitude with respect to time for an oscillation object is shown in figure.**

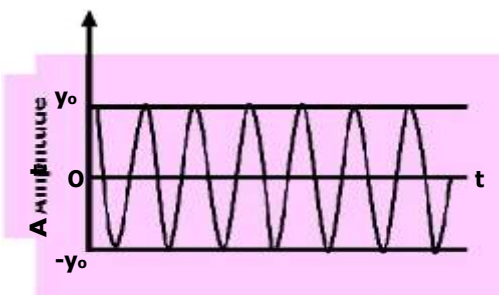

Identify the oscillation:

- A) Damped C) Undamped
 B) Critical D) Heavily damped

- Q.16** A 4.0 m long wire is subjected to stretching force and its length increases by 40 cm. The percent elongation which the wire undergoes is:
 A) 0.10 %
 B) 40 %
 C) 10 %
 D) 20 %
- Q.17** What is the value of universal gas constant?
 A) 8314 Jmol⁻¹K⁻¹
 B) 83.14 Jmol⁻¹K⁻²
 C) 831.4 Jmol⁻¹K⁻¹
 D) 8.314 Jmol⁻¹K⁻²

- Q.18** A gas sample contains three molecules each having speed 1 ms⁻¹, 2 ms⁻¹, 3 ms⁻¹. What is the mean square speed?
 A) 14/3 m/s
 B) 6 m/s
 C) 2 m/s
 D) $\sqrt{14/3}$ m/s
- Q.19** What is the factor upon which change in internal energy of an ideal gas depends?
 A) Change in volume
 B) Change in temperature and volume
 C) Change in temperature
 D) Path followed to change internal energy

- Q.20** What will be the mathematical form of first law of thermodynamics for a system whose variation of volume by pressure is shown?

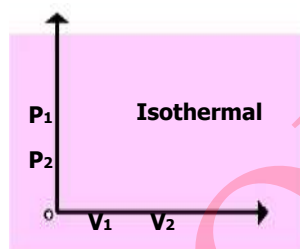

- A) $Q = U$
 B) $U = W$
 C) $Q = U/W$
 D) $Q = W$
- Q.21** For a heat engine 'A' ratio of Q_1 to Q_2 is 2/3 while that of heat engine 'B', ratio of Q_2 to Q_1 is 1/3. What is the value $\eta_A : \eta_B$?
 A) 1:3
 B) 1:2
 C) 2:3
 D) 2:1
- Q.22** What is the charge stored on a 5 μ F capacitor charged to potential difference of 12 V?
 A) 60 μ C
 B) 2.4 C
 C) 2.4 μ C
 D) 60 C
- Q.23** Which of the following is the proper way to study the sinusoidal wave form of voltage?
 A) Voltage is connected to 'Y' input and time base is switched on.
 B) Voltage is connected to 'X' input and time base is switched off.
 C) Voltage is connected to 'Y' input and time base is switched off.
 D) Voltage is connected to 'X' input and time base is switched on.
- Q.24** 12-volt battery is applied across 6-ohm resistance to have a steady flow of current. What must be the required potential difference across the same resistance to have a steady current of one ampere?
 A) 12 V
 B) 6 V
 C) 1 V
 D) 3 V
- Q.25** A solenoid is cut into two halves. Magnetic induction due to same current in each half will be:
 A) Half of the original
 B) Double of the original
 C) Same as original
 D) Four times of the original
- Q.26** A long straight current carrying conductor has current directed from bottom to top when held vertically. What will be the direction of magnetic field lines when observed from below the conductor?
 A) Clockwise
 B) Anti clockwise
 C) Vertically upward
 D) Vertically downward

Q.27 What is the output Boolean expression of logic diagram shown in figure below:

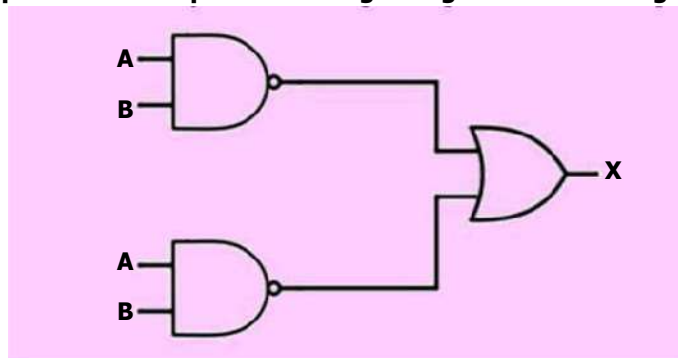

- A) $(A + \bar{B})(\bar{A} + B)$
- B) $(\bar{A} + \bar{B})(\bar{A} + B)$
- C) $\bar{A}\bar{B} + \bar{A}B$
- D) $\bar{A}\bar{B} + AB$

Q.28 Three resistors each having value 'R' are connected as shown in figure. What is the equivalence resistance between 'X' and 'Y'?

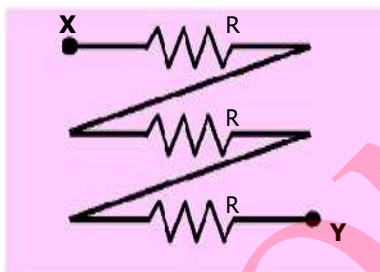

- A) R
- B) R/3
- C) 3R
- D) R³

Q.29 The diagram shows a wire, carrying a current 'I', placed between the poles of magnet: In which direction does the force on the wire act?

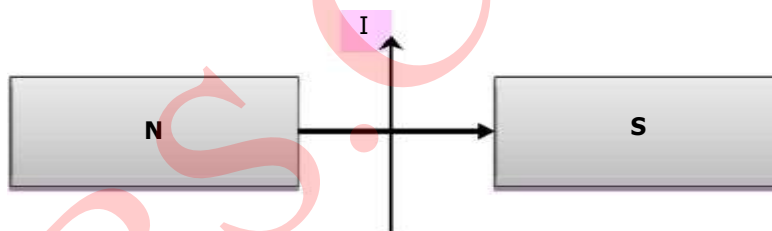

- A) Towards the 'N' pole of the magnet
- B) Downwards
- C) Upwards
- D) Towards the 'S' pole of the magnet

Q.30 X-rays from a given X-ray tube operating under specified conditions have a minimum wavelength. The value of this minimum wavelength could be reduced by:

- A) Cooling the target
- B) Reducing the temperature of the filament
- C) Increasing the potential difference between the cathode and the target
- D) Reducing the pressure in the tube

Q.31 Helium-neon lasers are used for the:

- A) Precise measurement of range finding
- B) Optical fiber communication systems
- C) Surveying for construction of tunnels
- D) Welding detached bone of body

Q.32 What is the type of characteristic X-ray photon whose energy is given by relation ' $hf = E_M - E_K$ '?

- A) K - alpha
- B) M - alpha
- C) K - beta
- D) M - beta

Q.33 Kinetic energy of electrons by applying potential difference V_1 across the x-ray tube is KE_1 while V_2 potential difference produce kinetic energy equal to KE_2 . What will be the value of $KE_1:KE_2$ if ratio of potential difference $V_1:V_2 = 2:3$?

- A) 3:2
- B) 4:9
- C) 9:4
- D) 2:3

Q.46 A sample of Neon is found to exist as ^{20}Ne , ^{21}Ne , ^{22}Ne . Mass spectrum of 'Ne' is as follow:

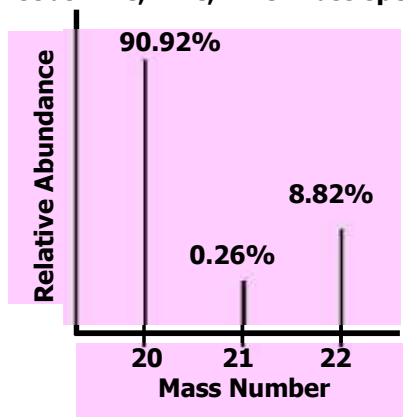

What is the relative atomic mass (A, value) of Neon?

- A) 20.18
B) 20.28
C) 20.10
D) 20.22
- Q.47 The coordination number of Na^+ in NaCl crystal is:
A) 6
B) 2
C) 4
D) 8
- Q.48 There are four gases H_2 , He , N_2 and CO_2 at 0°C . Which gas shows greater non-ideal behavior?
A) He
B) CO_2
C) H_2
D) N_2
- Q.49 Correct order of energy in the given subshells is:
A) $5s > 3d > 3p > 4s$
B) $5s > 3d > 4s > 3p$
C) $3p > 3d > 5s > 4s$
D) $3p > 3d > 4s > 5s$
- Q.50 Number of electrons in the outermost shell of chloride ion (Cl^-) is:
A) 17
B) 3
C) 1
D) 8
- Q.51 According to valence shell electron pair repulsion theory, the repulsive forces between the electron pair of central atom of molecule are in the order:
A) Lone Pair - Lone-Pair > Lone Pair - Bond Pair > Bond Pair - Bond Pair
B) Lone Pair - Bond Pair > Lone Pair - Lone Pair > Bond Pair - Bond Pair
C) Bond Pair - Bond Pair > Lone Pair - Lone Pair > Lone Pair - Bond Pair
D) One Pair - Bond Pair > Bond Pair - Bond Pair > Lone Pair - Lone Pair
- Q.52 In crystal lattice of ice, each O-atom of water molecule is attached to:
A) Four H-atoms
B) Three H-atoms
C) One H-atom
D) Two H-atoms
- Q.53 Heat of formation (ΔH_f°) for CO_2 is:
A) -394 kJ/mole
B) $+394 \text{ kJ/mole}$
C) -294 kJ/mole
D) -390 kJ/mole
- Q.54 Reactants have high energy than products in:
A) Exothermic reactions
B) Endothermic reactions
C) Photochemical reactions
D) Non-spontaneous reactions
- Q.55 If 18.0 g of glucose is dissolved in 1 kg of water, boiling point of this solution should be:
A) 100.52°C
B) 100.00°C
C) 100.052°C
D) Less than 100°C
- Q.56 Molal freezing point constant of water is:
A) 1.86
B) 2.86
C) 11.86
D) 0.52

Q.57 In the figure given below, the electron flow in external circuit is from:

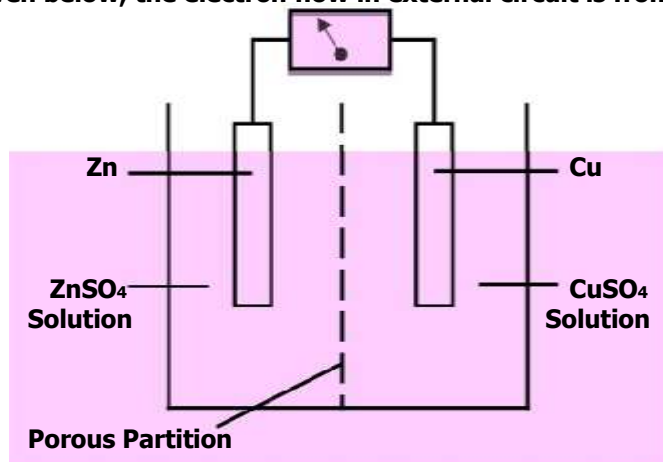

- A) Copper to zinc electrode
 B) Right to left
 C) Porous partition to zinc electrode
 D) Zinc to copper electrode

Q.58 By considering Arrhenius equation, the graph between ' $\frac{1}{T}$ ' and 'log K' given a curve of the type:

- A)
- B)
- C)
- D)

Q.59 Which one of the following is a redox reaction?

- A) $\text{NaCl} + \text{AgNO}_3 \longrightarrow \text{NaNO}_3 + \text{AgCl}$
 B) $2\text{Cl} \longrightarrow \text{Cl}_2 + 2\text{e}^-$
 C) $2\text{Na} + \text{Cl}_2 \longrightarrow 2\text{NaCl}$
 D) $\text{Na}^+ + 1\text{e}^- \longrightarrow \text{Na}$

Q.60 The chemical substance, when dissolved in water, gives "H⁺" is called:

- A) Acid
 B) Base
 C) Amphoteric
 D) Neutral

Q.61 The 'pH' of our blood is:

- A) 6.7 - 8
 B) 7.9
 C) 7.5
 D) 7.35 - 7.4

Q.62 In zero order reactions, the rate is independent of:

- A) Concentration of the product
 B) Concentration of the reactant
 C) Temperature of the reaction
 D) Surface area of the product

Q.63 What is the trend of melting and boiling point of the elements of short periods as we move from left to right in a periodic table?

- A) Melting and boiling points first decrease then increase
 B) Melting and boiling points increase gradually
 C) Melting and boiling points first increase then decrease
 D) Melting and boiling points decrease gradually

Q.64 Along a period, atomic radius decreases. This gradual decrease in radius is due to:

- A) Increase in number of electrons in valence shells
 B) Increase in number of protons in the nucleus
 C) Decrease in number of shells
 D) Increase in number of shells

Q.65 Alkaline earth metal oxides react with water to give hydroxides. The solubility of alkaline earth metal oxides in water increases as we move from top to bottom in a group. Which of the following alkaline earth metal oxides is least soluble in water?

- A) MgO
 B) CaO
 C) BaO
 D) SrO

Q.66 The electronic structure of carbon monoxide is represented as:

- A) $\text{:C} \equiv \text{O:}$
 B) $\text{:C} \text{---} \ddot{\text{O}} \text{:}$
 C) $\text{C} \equiv \ddot{\text{O}} \text{:}$
 D) $\dot{\text{C}} \equiv \ddot{\text{O}}$

Q.67 Which one pair has the same oxidation state of 'Fe'?

- A) FeSO₄ and FeCl₃
 B) FeCl₂ and FeCl₃
 C) FeSO₄ and FeCl₂
 D) Fe₂(SO₄)₃ and FeSO₄

Q.68 Oxidation state of 'Fe' in K₃[Fe(CN)₆] is:

- A) +2
 B) +3
 C) -6
 D) -3

Q.69 The nature of an aqueous solution of ammonia (NH₃) is:

- A) Amphoteric
 B) Neutral
 C) Acidic
 D) Basic

Q.70 Unpolluted rain water has a pH of:

- A) 4.9
 B) 5.6
 C) 5.3
 D) 7.0

Q.71 In comparison with oxygen gas, a strong triple bond is present between two nitrogen atoms in a molecule and therefore nitrogen gas is:

- A) Highly reactive gas
 B) Completely inert like noble gases
 C) Moderately reactive gas
 D) Very less reactive gas

Q.72 The catalyst used in the Haber's process is:

- A) Magnesium oxide
 B) Aluminium oxide
 C) Silicon oxide
 D) Iron crystals with metal oxide promoters

Q.73 The cis-isomerism is shown by:

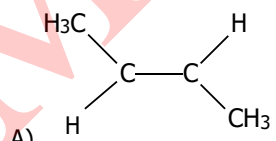
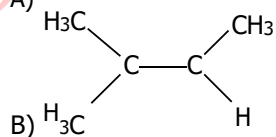
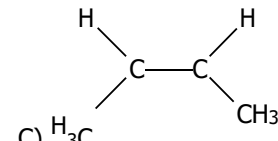
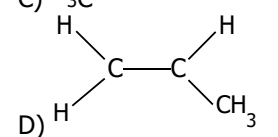
- A) 
 B) 
 C) 
 D) 

Q.74 Select the nucleophile from the following examples:

- A) NO₂
 B) NH₃
 C) NO₂⁺
 D) N⁺H₄

Q.75 The introduction of an alkyl group in benzene takes place in the presence of AlCl_3 and:

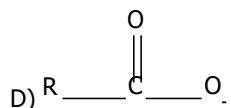
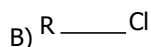
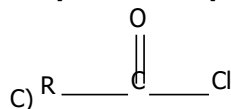
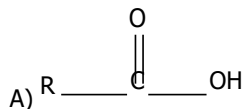

Q.76 What is the product formed when propene reacts with HBr ?

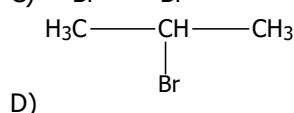
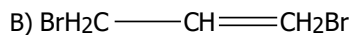
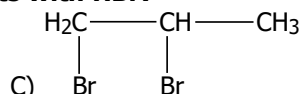
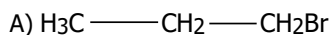

Q.77 The order of reactivity of alkyl halides towards nucleophile is:

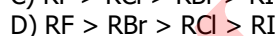
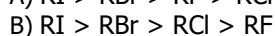
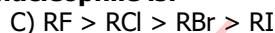
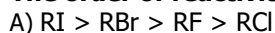

Q.78 Consider the reaction given below:

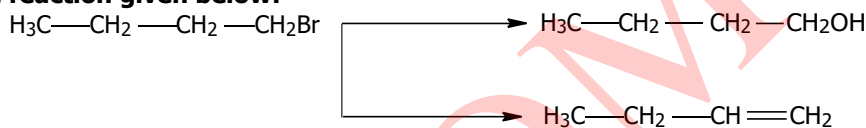

Which statement is true?

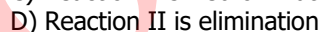
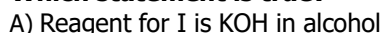

Q.79 Consider the following reaction:



What product(s) may be formed?

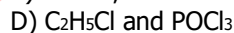
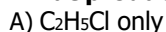

Q.80

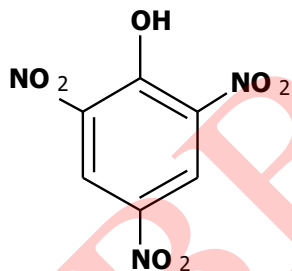

is named as:

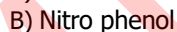

Q.81 Which group gives a yellow precipitate of triiodo methane when warmed with alkaline aqueous iodine?

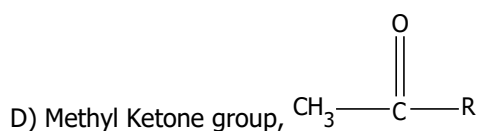
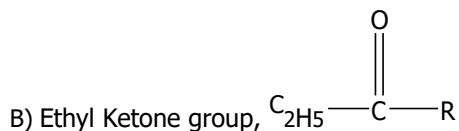
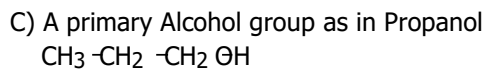
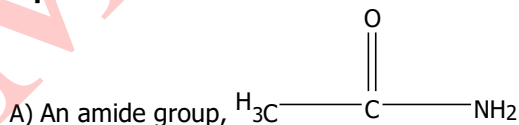

Q.82 Aqueous phenol decolorizes bromine water to form a white precipitate. What is the structure of the white precipitate formed?

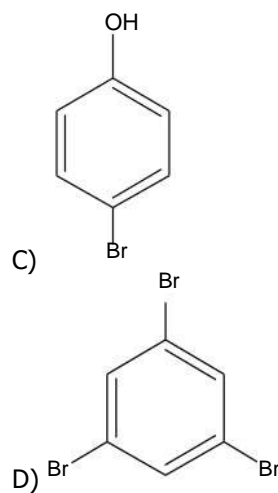
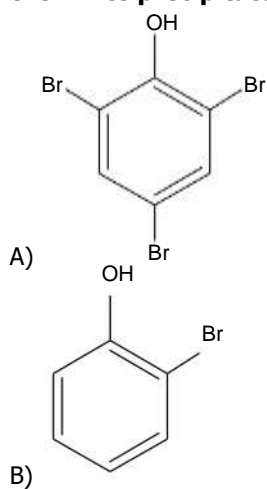

Q.83 The relative strength of carboxylic acid, water, ethanol and phenol has the following order of increasing acid strength:

- A) Carboxylic Acid > Phenol > Ethanol > Water
 B) Carboxylic Acid > Phenol > Water > Ethanol

- C) Phenol > Carboxylic Acid > Ethanol > Water
 D) Water > Ethanol > Phenol > Carboxylic Acid

Q.84 What is the structure of alcohol which on oxidation with acidified $\text{Na}_2\text{Cr}_2\text{O}_7$ gives



A)

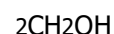

3

B)



D)

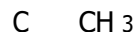

Q.85 Which of the following is the structure of ketone?

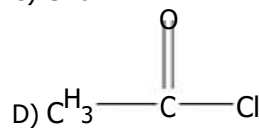
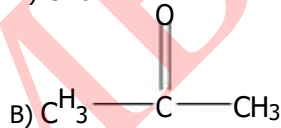
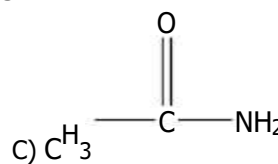
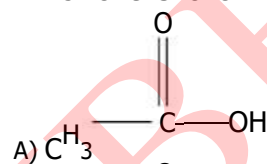

Q.86 The formation of ester from acetic acid in presence of acid and ethanol is a:

- A) Nucleophilic substitution reaction
 B) Nucleophilic addition reaction

- C) Electrophilic substitution reaction
 D) Electrophilic addition reaction

Q.87 Methyl cyanides, on boiling with mineral acids or alkalis yield:

- A) Acetic acid
 B) Formic acid

- C) Propanoic acid
 D) Butanoic acid

Q.88 The amino acids which largely exist in dipolar ionic form are:

- A) Acidic amino acids
 B) Basic amino acids

- C) Beta amino acids
 D) Alpha amino acids

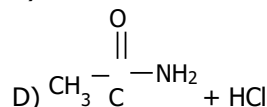
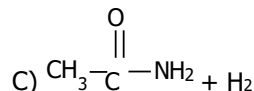
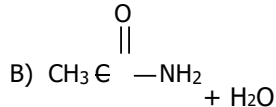
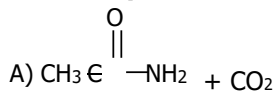
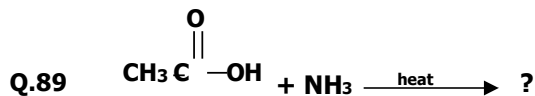

Q.90 The reaction:

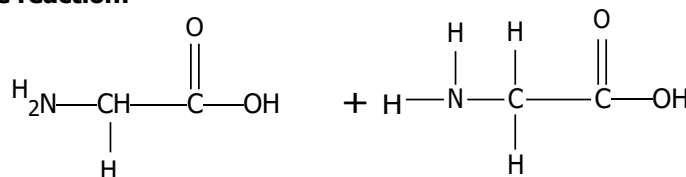

Gives a product called dipeptide molecule represented by:

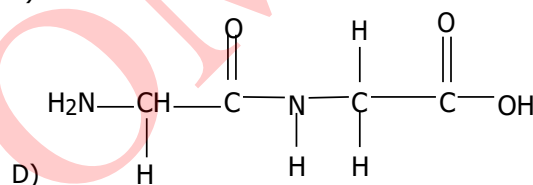
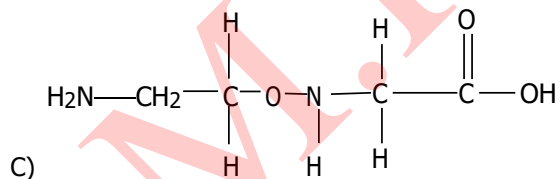
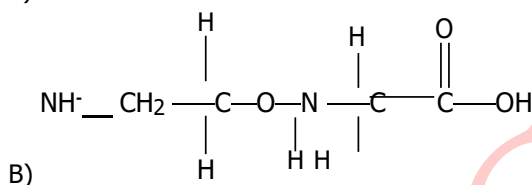
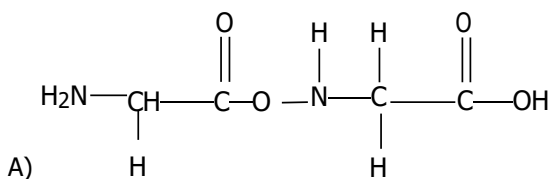

Q.91 Two or more amino acids condensed to form protein by a peptide linkage which is present between two atoms:

- A) C and C
 B) O and C

- C) C and N
 D) C and H

Q.92 α -amino acids are compounds having carboxylic acid as well as amino functional groups attached to:

- A) Any H-atom in the molecule
 B) Same carbon atom

- C) Alternate carbon atoms
 D) Neighboring carbon atoms

Q.93 The formula of 'Zwitter ion' is represented by:

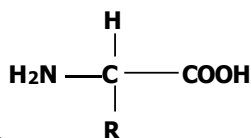
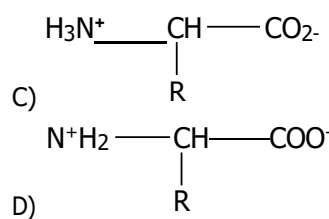
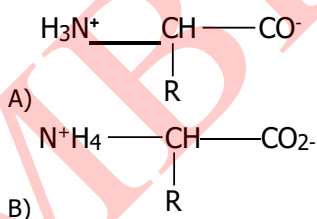

Q.94 What is the name of amino acid,

- A) Glycine
 B) Lysine

where 'R' is CH₃ group?

- C) Aspartic acid
 D) Alanine

Q.95 Polyvinyl acetate (PVA) is colourless and non-toxic resin used as an adhesive and as a binder for making:

- A) Toys
 B) Gramophone recorders

- C) Compact discs
 D) Emulsion paints

- Q.96 Both ribose and deoxyribose are monosaccharides containing _____ carbon atoms.**
A) Four
B) Six
C) Five
D) Seven
- Q.97 The increased quantities of cholesterol in blood make plaque like deposits in the arteries causing:**
A) Cholera
B) Down's syndrome
C) Heart attack
D) Phenylketonuria
- Q.98 Polyvinyl chloride is an example of:**
A) Condensation polymer
B) Addition polymer
C) Biopolymer
D) Thermosetting polymer
- Q.99 Collagen is a fibrous protein present most abundantly in:**
A) Hair
B) Nail
C) Tendons
D) Arteries
- Q.100 Animals store glucose in the form of glycogen in:**
A) Stomach
B) Mouth
C) Liver and muscles
D) Small intestine
- Q.101 Aerobic decomposition of organic matter i.e. glucose by bacteria in water sediments produces:**
A) Propene
B) Ethane
C) Methane
D) Butane
- Q.102 The yellowish-brown color in photochemical smog is due to the presence of:**
A) Sulphur dioxide
B) Carbon monoxide
C) Carbon dioxide
D) Nitrogen dioxide

ENGLISH

- Q.103 Indolence gives vent to _____ disposition in human life.**
A) Static
B) Enthusiastic
C) Energetic
D) Filthy
- Q.104 The Quaid's _____ enthusiasm led the Muslims Indo-Pak to independence.**
A) Simplified
B) Latent
C) Onerous
D) Threatening
- Q.105 He _____ the incident to the back of his mind.**
A) Revered
B) Regulated
C) Reagitated
D) Relegated
- Q.106 He _____ the day they had bought such a large house**
A) Hues
B) Rows
C) Rues
D) Dues

⇒ **SPOT THE ERROR: In the following sentences, some segments of each sentence are underlined. Your task is to identify that underlined segment of the sentence, which contains the mistake that needs to be corrected. Fill the Circle corresponding to that letter under the segment in the MCQ Response Form.**

- Q.107** Amjad was not conscious to the aberration he had committed in the public meeting. It was disliked by all and sundry.
A) B) C) D)
- Q.108** Late Agha Shahi was an outstanding genius in the international affairs. He was gifted of the acumen to judge the future events, judge the future events in advance.
A) B) C) D)

- Q.109** The old man was sitting quite bamboozled when the swindler deprived him from his pension money
A) B)
by his evil tricks.
C) D)
- Q.110** The prime minister fired a broadside at the opposition leaders. A few of his remarks were not up at the mark.
A) B) C) D)
- Q.111** Lucy is the diva which performance as an opera singer is peerless.
A) B) C) D)
- Q.112** The police report exonerated Anwar of all charges of corruption and job was also restored
A) B) C) D)



In each of the following question, four alternative sentences are given. Choose the CORRECT one and fill the Circle corresponding to that letter in the MCQ Response Form.

- Q.113**
A) We should pay maximum accolade for our national heroes.
B) We should pay maximum accolade in our national heroes.
C) We should pay maximum accolade to our national heroes.
D) We should pay maximum accolade from our national heroes.
- Q.114**
A) Does any bodys knows why the latitudes close to the equator are called the horse latitudes?
B) Do any body knows why the latitudes close to the equator are called the horse latitudes?
C) Does any body knows why the latitudes close to the equator are called the horse latitudes?
D) Does any body know why the latitudes close to the equator are called the horse latitudes?
- Q.115**
A) Shelley is consider to be an idealist poet. C) Shelley is considers to be an idealist poet.
B) Shelley is considering to be an idealist poet. D) Shelley is considered to be an idealist poet.
- Q.116**
A) Pakistan cricket team forged an impregnable lead.
B) Pakistan cricket team forged the impregnable lead.
C) Pakistan cricket team forged against impregnable lead.
D) Pakistan cricket team forged on impregnable lead.
- Q.117**
A) A person which job involves calculating insurance risks and payments for insurance companies by studying how frequently fires, accidents, death etc. happen is called an actuary.
B) A person who job involves calculating insurance risks and payments for insurance companies by studying how frequently fires, accidents, death etc. happen is called an actuary.
C) A person whose job involves calculating insurance risks and payments for insurance companies by studying how frequently fires, accidents, death etc. happen is called an actuary.
D) A person whose job involves calculating insurance risks and payments for insurance companies by studying how frequently fires, accidents, death etc. happen are called an actuary.
- Q.118**
A) His addled brain refuse to think clearly and solve the problem.
B) His addle brain refused to think clearly and solve the problem.
C) His addle brain refuse to think clearly and solve the problem.
D) His addled brain refused to think clearly and solve the problem.
- Q.119**
A) The children had bloomed while their stay on the farm.
B) The children had bloomed during their stay on the farm.
C) The children had bloomed on their stay on the farm.
D) The children was bloomed while their stay on the farm.

Q.120

- A) I should had business acumen.
- B) I should have business acumen.
- C) I should has business acumen.
- D) I should may have been business acumen.

Q.121

- A) No one is casting aspersions to you.
- B) No one is casting aspersions at you.
- C) No one is casting aspersions on you.
- D) No one is casting aspersions with you.

Q.122

- A) This is one of the bifurcated road.
- B) This is one of the bifurcated roads.
- C) This is one of them bifurcated road
- D) This is one off the bifurcated road.



In each of the following question, four alternative meanings of a word are given. You have to select the NEAREST CORRECT MEANING of the given word and fill the appropriate Circle on the MCQ Response Form.

Q.123 **HEINOUS**

- A) Heroic
- B) Humorous
- C) Odious
- D) Hone

Q.124 **ILLICIT**

- A) Intimate
- B) Licentious
- C) Illegal
- D) Limited

Q.125 **MOTIF**

- A) Tough
- B) Stuff
- C) Motion
- D) Design

Q.126 **INCULCATE**

- A) Calculate
- B) Instill
- C) Instigate
- D) Stimulate

Q.127 **INIQUITY**

- A) Inequality
- B) Injustice
- C) Wickedness
- D) Efficiency

Q.128 **INTRANSIGENT**

- A) Parallel
- B) Inflexible
- C) Adventurous
- D) Spirited

Q.129 **LAMPOON**

- A) Irk
- B) Gratification
- C) Lacerate
- D) Ridicule

Q.130 **MESMERIZE**

- A) Objectify
- B) Modify
- C) Amalgamate
- D) Fascinate

Q.131 **OBLITERATE**

- A) Sanctify
- B) Obscure
- C) Annihilate
- D) Oplate

Q.132 **MALEVOLENCE**

- A) Empathy
- B) Maligning
- C) Hostility
- D) Management

BIOLOGY

Q.133 **The simplest independent unit of life is known as:**

- A) Bacterial colony
- B) Cell
- C) Chloroplast
- D) DNA

- Q.134 The process by which unwanted structures within the cell are engulfed and digested within the lysosome is known as:**
 A) Endocytosis
 B) Exocytosis
 C) Hydrolysis
 D) Autophagy
- Q.135 The plants having foreign DNA incorporated into their cells are called:**
 A) Clonal plants
 B) Transgenic plants
 C) Biotech plants
 D) Tissue cultured plants
- Q.136 Pasteurization technique is widely used for preservation of:**
 A) Water
 B) Heat
 C) Milk products
 D) Vaccines
- Q.137 The production of genetically identical copies of organisms by asexual reproduction is called:**
 A) Genetic engineering
 B) Integrated disease management
 C) Hydroponic culture technique
 D) Cloning
- Q.138 The _____ model of plasma membrane suggests that proteins are embedded in lipid bilayer:**
 A) Unit membrane
 B) Fluid mosaic
 C) Permeable
 D) Ultracentrifuge
- Q.139 The function of nucleolus is to make:**
 A) rDNA
 B) Ribosomes
 C) RNA
 D) Chromosomes
- Q.140 Lipid metabolism is the function of:**
 A) Mitochondria
 B) Sarcoplasmic reticulum
 C) RER
 D) SER
- Q.141 The enzymes of lysosomes are synthesized on:**
 A) RER
 B) SER
 C) Chloroplast
 D) Golgi Apparatus
- Q.142 Centrioles are made up of _____ microtubules:**
 A) 9
 B) 27
 C) 3
 D) 12
- Q.143 Which of the following structures is absent in higher plants and found in animal cells:**
 A) Centriole
 B) Cytoskeleton
 C) Mitochondria
 D) Cytoplasm
- Q.144 The soluble part of cytoplasm or fluid that remains when all organelles are removed is known as:**
 A) Solution
 B) Gelatin material
 C) Cytoskeleton
 D) Cytosol
- Q.145 The outer membrane of the nuclear envelope is at places continuous with the:**
 A) Golgi apparatus
 B) Endoplasmic Reticulum
 C) Lysozymes
 D) Peroxisomes
- Q.146 Down's syndrome is a result of non-disjunction of _____ pair of chromosomes that fails to segregate:**
 A) 21st
 B) 22nd
 C) 18th
 D) 24th
- Q.147 _____ is most abundant carbohydrate in nature.**
 A) Waxes
 B) Glycerol
 C) Starch
 D) Cellulose
- Q.148 Which of the following is a keto sugar:**
 A) Glyceraldehyde
 B) Dihydroxy-acetone
 C) Ribose
 D) Glucose

Q.149 Amino acid in which the R-group is hydrogen is:

- A) Glycine
- B) Alanine
- C) Leucine
- D) Valine

Q.150 Acyl-glycerols like fats and oils are esters formed by condensation reaction between:

- A) Fatty acids and water
- B) Fatty acids and alcohols
- C) Fatty acids and glucose
- D) Fatty acids and phosphates

Q.151 Which of the following is purine:

- A) Guanine
- B) Cytosine
- C) Thymine
- D) Uracil

Q.152 If the co-factor is covalently or tightly and permanently bonded to enzyme then it will be called:

- A) Coenzyme
- B) Prosthetic group
- C) Activator
- D) Apoenzyme

Q.153 Optimum pH value for the working of pancreatic lipase is:

- A) 4.50
- B) 7.60
- C) 2.00
- D) 9.00

Q.154 The view that active site of an enzyme is flexible and when a substrate combines with it, cause changes in enzyme structure is known as:

- A) Lock & key model
- B) Induce fit model
- C) Sliding filament model
- D) Specificity model

Q.155 All coenzymes are derived from:

- A) Proteins
- B) Nucleic acids
- C) Carbohydrate
- D) Vitamins

Q.156 Reverse transcription is used to make DNA copies of:

- A) Host RNA
- B) Viral RNA
- C) Host DNA
- D) Viral DNA

Q.157 Antibiotics are produced by fungi and certain bacteria of group:

- A) Actinomycetes
- B) Oomycetes
- C) Ascomycetes
- D) Basidiomycetes

Q.158 Which statement about bacteria is true:

- A) Gram positive bacteria have more lipids in their cell wall
- B) Gram negative bacteria have more lipids in their cell wall
- C) Lipids are absent in cell wall of both gram positive and negative bacteria
- D) Both have equal amount of lipids

Q.159 Fungi which cause thrush in humans:

- A) Sarcomeres
- B) Candidiasis
- C) Lovastatin
- D) Aspergillus

Q.160 When beef which is not properly cooked is consumed by humans, they become infected by:

- A) Tape worm
- B) Hook worm
- C) Pin worm
- D) Round worm

Q.161 Sleeping sickness in humans is caused by:

- A) Trypanosoma
- B) Plasmodium
- C) Anopheles
- D) Andes

Q.162 Schistosoma is a parasite that lives in the _____ of the host.

- A) Intestine
- B) Kidney
- C) Liver
- D) Blood

Q.163 The cavity between body wall and alimentary canal is:

- A) Coelom
- B) Mesoderm
- C) Endoderm
- D) Mesoglea

- Q.164 The layer which forms the lining of digestive tract and glands of digestive system is:**
 A) Ectoderm
 B) Mesoderm
 C) Endoderm
 D) Mesoglea
- Q.165 Which one of the following vitamins is produced by microflora of large intestine?**
 A) Vitamin K
 B) Vitamin C
 C) Vitamin A
 D) Vitamin D
- Q.166 _____ is activated to _____ by Enterokinase/enteropeptidase enzyme secreted by the lining of duodenum:**
 A) Pepsinogen, Pepsin
 B) Pepsinogen, Trypsin
 C) Trypsinogen, Trypsin
 D) Chymotrypsinogen, Chymotrypsin
- Q.167 Which of the following are absorbed in the large intestine?**
 A) Water and salts
 B) Water and peptones
 C) Salts and glycerol
 D) Amino acids and sugars
- Q.168 Saliva is basically composed of water, mucus, amylase and:**
 A) Sodium bicarbonate
 B) Sodium chloride
 C) Sodium hydroxide
 D) Hydrocarbons
- Q.169 The total inside capacity of lungs is _____ for man.**
 A) 6.7 liters
 B) 2.5 liters
 C) 7 liters
 D) 5 liters
- Q.170 The average life span of red blood cell is about:**
 A) Four months
 B) Two months
 C) Five months
 D) One month
- Q.171 The lymphatic vessels of the body empty the lymph into blood stream at the:**
 A) Abdominal vein
 B) Subclavian vein
 C) Jugular vein
 D) Bile duct
- Q.172 Right atrium is separated from right ventricle by:**
 A) Tricuspid valve
 B) Bicuspid valve
 C) Semilunar valve
 D) Septum
- Q.173 Site of filtration in nephron is:**
 A) Glomerulus and Bowman's capsule
 B) Proximal and Distal end
 C) Ascending and descending arm
 D) Loop of Henle
- Q.174 Antidiuretic hormone increases the reabsorption of:**
 A) Amino acids
 B) Salts
 C) Ammonia
 D) Water
- Q.175 Active uptake of _____ in the ascending limb or thick loop of Henle is promoted by the action of aldosterone:**
 A) K^+
 B) Cl^-
 C) Ca^{++}
 D) Na^+
- Q.176 The process through which the body maintains the internal environment from the fluctuations of external environment is called as:**
 A) Behavior of organisms
 B) Adaptation
 C) Thermoregulation
 D) Homeostasis
- Q.177 Active pumping out of Na^+ occurs at which part of nephron:**
 A) Proximal tubule
 B) Descending loop of Henle
 C) Ascending loop of Henle
 D) Collecting ducts
- Q.178 The structures which respond when they are stimulated by impulse coming through motor neuron are:**
 A) Receptors
 B) Responders
 C) Transducers
 D) Effectors

Q.179 Thalamus and cerebrum are the part of:

- A) Fore brain
- B) Mid brain
- C) Hind brain
- D) Spinal cord

Q.180 There is also EVIDENCE that high levels of _____ may contribute to the onset of Alzheimer's disease:

- A) Mg
- B) Mo
- C) Al
- D) Ca

Q.181 L-dopa or Levodopa is used to get some relief from??

- A) Epilepsy
- B) Alzheimer's disease
- C) Parkinson's disease
- D) Dementia

Q.182 Spermatogonia differentiate directly into?

- A) Primary spermatocytes
- B) Secondary spermatocytes
- C) Spermatozoa
- D) Spermatids

Q.183 Treponema palladium causes?

- A) AIDS
- B) Genital herpes
- C) Syphilis
- D) Gonorrhoea

Q.184 What is the location of interstitial cells in testes?

- A) Inside the seminiferous tubules
- B) Between the seminiferous tubules
- C) Among the germinal epithelial cells
- D) Around the testes

Q.185 A type of cells in human testes which produce testosterone are called?

- A) Germ cells
- B) Sertoli cells
- C) Interstitial cells
- D) Spermatocytes

Q.186 The hormone produced from corpus luteum is:

- A) Prolactin
- B) FSH
- C) Progesterone
- D) LH

Q.187 The length of myofibril from one Z-band to the next is described as:

- A) Sarcolemma
- B) Sarcoplasm
- C) Sarcomere
- D) Muscle fiber

Q.188 The Ca⁺⁺ ions released during a muscle fiber contraction attach with:

- A) Myosin
- B) Actin
- C) Troponin
- D) Tropomyosin

Q.189 The joint that allows the movement in several directions is called:

- A) Hinge joint
- B) Ball and Socket joint
- C) Cartilaginous joint
- D) Fibrous joint

Q.190 Where can we find H zone in the figure of fine structure of skeletal muscle's myofibril?

- A) In the mid of A band
- B) In I-band
- C) Besides the Z-line
- D) Along the I-band

Q.191 First vertebra of cervical region of vertebral column is known as:

- A) Atlas
- B) Sacral
- C) Thoracic
- D) Axis

Q.192 Chemically insulin and glucagon are:

- A) Carbohydrates
- B) Proteins
- C) Lipids
- D) Nucleic acids

Q.193 Hormones secreted by anterior pituitary and which controls the secretion of hormones of other endocrine glands are known as:

- A) Release factor
- B) Inhibitor
- C) Accelerator
- D) Tropic or trophic hormones

- Q.194 Alpha cells of Islets of Langerhans secrete hormone called:**
A) Glucocorticoid C) Glucagon
B) Insulin D) Aldosterone
- Q.195 Which of the following is the function of glucagon hormone?**
A) Glucose to lipids C) Glucose to glycogen
B) Glucose to proteins D) Glycogen to glucose
- Q.196 In passive immunity which of the following components are injected into body?**
A) Antigens C) Serum
B) Immunogens D) Immunoglobulins
- Q.197 Which part of the antibody recognizes the antigen during immune response?**
A) Heavy part C) Light part
B) Variable part D) Consonant part
- Q.198 Two identical light chains and two identical heavy chains in antibody molecule are linked by:**
A) Disulphide bridges C) Glycerol bond
B) Peptide bond D) Ionic bond
- Q.199 Antibodies are produced against invading cells by:**
A) Lymphocytes C) Basophils
B) Basophils D) Neutrophils
- Q.200 In the structural diagram of an antibody molecule which portion is occupied by variable chains?**
A) Lower region C) Middle region
B) Upper region D) In between chains
- Q.201 Every molecule of NADH, fed into ETC produces:**
A) 2 ATP C) 4 ATP
B) 3 ATP D) 6 ATP
- Q.202 Final acceptor of electrons in respiratory chain is:**
A) Cytochrome a C) Cytochrome a³
B) Oxygen D) Cytochrome c
- Q.203 The end product of anaerobic respiration in humans and other mammals is:**
A) Pyruvic acid C) Lactic acid
B) Ethanol D) Glucose
- Q.204 A biochemical process which occurs within a cell to breakdown complex compounds to produce energy is called:**
A) Respiration C) Oxidation reduction
B) Photosynthesis D) Photophosphorylation
- Q.205 Which part of chlorophyll molecule absorbs light?**
A) Phytol C) Pyrrole
B) Porphyrin ring D) Thylakoid membrane
- Q.206 The DNA molecule formed from messenger-RNA by reverse transcriptase is called??**
A) Complementary DNA C) Chimeric DNA
B) Recombinant DNA D) Plasmid DNA
- Q.207 The agent which separates the two strands of DNA in PCR is??**
A) DNA ligase C) Heat
B) Primer D) Helicase
- Q.208 Cystic fibrosis patient lack a gene that codes for trans-membrane carrier of??**
A) Na⁺ ions C) Ca⁺⁺ ions
B) Cl⁻ ions D) K⁺ ions

Q.209 The phage commonly used as a vector in genetic engineering is?

- A) Lambda phage
- B) Gamma phage
- C) T₂ phage
- D) T₄ phage

Q.210 Restriction endonucleases are naturally occurring enzymes of:

- A) Viruses
- B) Bacteria
- C) Fungi
- D) Plants

Q.211 In an ecosystem mycorrhizae are an example of:

- A) Predation
- B) Symbiosis
- C) Mutualism
- D) Parasitism

Q.212 As a result of destruction of ozone layer there is significant increase in:

- A) Ultra-violet radiations
- B) Greenhouse gases
- C) Nitrogen oxide
- D) Sulphur oxide

Q.213 Higher rate of a biological activity in a nutrient rich pond water is called:

- A) Water pollution
- B) Air pollution
- C) Eutrophication
- D) Industrial effects

Q.214 Living part of ecosystem is:

- A) lithosphere
- B) Hydrosphere
- C) Community
- D) Biosphere

Q.215 A living association between two living organisms of different species which is beneficial to both the partners is called:

- A) Commensalism
- B) Parasitism
- C) Mutualism
- D) Predation

Q.216 The structures which are reduced during the course of evolution and have no apparent function are called:

- A) Regenerated organs
- B) Vestigial organs
- C) Saltatory organs
- D) Useless organs

Q.217 When a gene suppresses the effect of another gene at another locus the phenomenon is termed as:

- A) Over dominance
- B) Pleiotropy
- C) Epistasis
- D) Co-dominance

Q.218 Phenylketonuria is an example of:

- A) Polyploidy
- B) Transmutation
- C) Inversion
- D) Point mutation

Q.219 A situation in which one gene affects two or more unrelated characters is called:

- A) Epistasis
- B) Pleiotropy
- C) Dominance relation
- D) Polygenes

Q.220 The mutation which causes change in the sequence of DNA is called:

- A) Point mutation
- B) Chromosomal mutation
- C) Deletion
- D) Inversion

MBBS.COM.PK

UHS MDCAT PAST PAPERS
BOOK Hard Copy Available
Now.

MBBS.COM.PK
EDUCATION SYSTEM

MDCAT GUIDE
UHS ENTRY TEST

MDCAT

PAST PAPER 2008-2019

- UNIT-WISE SOLVED MCQ's
- HIGHLIGHT REPEATED MCQ's
- CHANGING THE WAY YOU THINK
- BEST SOURCE TO GET HIGH MARKS
- UPDATED EDITION 2020
- AS PER UHS SYLLABUS

START
ENTRY TEST
PREPARATION
2020

LIVE CHAT
0304-7418334

Rs. 1400/=

Free Home Delivery

TO Book Order For MDCAT Past Papers
Call Or WhatsApp 0304-7418334

University of Health Sciences, Lahore



Total MCQs: 220

Max. Marks: 1100

ENTRANCE TEST - 2015

For F.Sc. and Non-F.Sc. Students
Time Allowed: 150 minutes

Instructions:

- Read the instructions on the MCQs Response Form carefully.
- Choose the **Single Best Answer** for each question.
- Candidates are strictly prohibited from giving any identification mark except Roll No. & Signature in the specified columns only.

COMPULSORY QUESTION FOR IDENTIFICATION

Q-ID. What is the color of your Question Paper?

A) White.

C) Pink.

B)

Blue.

D) Green.

ID

Ans: Colour of your Question Paper is Blue. Fill the Circle Corresponding to Letter 'B' against 'ID' in your MCQ response form (Exactly as shown in the diagram).

	A	B	C	D
	<input type="radio"/>	<input checked="" type="radio"/>	<input type="radio"/>	<input type="radio"/>
1	<input type="radio"/>	<input type="radio"/>	<input type="radio"/>	<input type="radio"/>
2	<input type="radio"/>	<input type="radio"/>	<input type="radio"/>	<input type="radio"/>
3	<input type="radio"/>	<input type="radio"/>	<input type="radio"/>	<input type="radio"/>
4	<input type="radio"/>	<input type="radio"/>	<input type="radio"/>	<input type="radio"/>

PHYSICS

Q.1 One method of creating an inverted population is known as _____ and consist of illuminating the laser material with light.

- A) Optical Pumping
C) Excitation

- C) Bremsstrahlung
D) Holography

Q.2 In population inversion (Ruby Laser) atoms can reside in the excited state for:

- A) 10^{-11}
C) 10^{-8}

- C) 10^{-3}
D) 10^{+3}

Q.3 If electrons of charge 'e' moving with velocity 'v' are accelerated through a potential difference 'V' and strike a metal target, then velocity of electrons is:

A) $\frac{Ve}{m}$

C) $\sqrt{\frac{Ve}{2m}}$

B) $\sqrt{\frac{Ve}{m}}$

D) $\sqrt{2Ve}$
m

Q.4 In X-ray tube, electrons after being accelerated through velocity 'v' strike the target, then the wavelength of emitted X-rays is:

A) Not greater than $\frac{hc}{eV}$

C) Equal to the $\frac{h}{mV}$

B) Not less than $\frac{hc}{eV}$

D) Equal to $\frac{h}{eV}$

Q.5 In the reaction, ${}_{92}^{234}\text{Th} \rightarrow {}_{91}^{234}\text{Y} + {}_{-1}^0\text{e}$ the electron ${}_{-1}^0\text{e}$ emits from the

- Q.6 A) 1st Orbit
 B) 2nd Orbit
 C) Nucleus
 D) Valence Shell

According to the equation ${}^A_Z\text{X} \rightarrow \text{Y} + 3\alpha$ particles, what are the atomic and mass numbers of 'Y'?

- A) $Z - 6, A - 12$
 B) $Z - 2, A - 4$
 C) $Z + 1, A$
 D) $Z + 3, A$

Q.7 A certain radioactive nuclide of mass number 'x' decays by β -emission and α -emission to a second nuclide of mass number 't'. Which of following correctly relates 'x' and 't'?

- A) $x = t + 4$
 B) $x = t - 4$
 C) $x - 3 = t$
 D) $x - 1 = t$

Q.8 During the decay of radioactive isotopes ${}^{23}\text{X}$ to a stable isotope, six α -particles and four β -particles are emitted, what is the atomic number 'Z' and mass number 'A' of the stable isotopes.

- A) $Z = 70, A = 220$
 B) $Z = 78, A = 212$
 C) $Z = 82, A = 212$
 D) $Z = 82, A = 208$

Q.9 Cobalt 60 is used in medicine and is an intense source of:

- A) α -particles
 B) β -particles
 C) γ -rays
 D) Neutrons

Q.10 In fluid flow, for the equation of continuity $A_1v_1 = A_2v_2$. If velocity of the fluid at one end is doubled, then what will be the cross-sectional area at this end?

- A) Double
 B) Half
 C) $(\text{Half})^2$
 D) $(\text{Double})^2$

Q.11 The value of least distance vision for normal eye is

- A) 20 cm
 B) 30 cm
 C) 25 cm
 D) 40 cm

Q.12 The distance between two dark adjacent fringes is mathematically written as:

- A) $\Delta Y = \frac{\lambda L}{d}$
 B) $\Delta Y = \frac{\lambda}{dL}$
 C) $\Delta Y = \frac{\lambda d}{L}$
 D) $\Delta Y = \frac{L}{\lambda d}$

Q.13 In Young's Double Slit Experiment, slit separation $x = 0.05$ cm, distance between screen and slit $D = 200$ cm, fringes separation $x = 0.13$ cm, then the wavelength ' λ ' of light is:

- A) $\lambda = 1.23 \times 10^{-2}$ m
 B) $\lambda = 3.25 \times 10^{-7}$ m
 C) $\lambda = 4.55 \times 10^{-5}$ m
 D) $\lambda = 5.1 \times 10^{-7}$ m

Q.14 In normal adjustment of compound microscope, the eye piece is positioned so that the final image is formed at:

- A) Optical Center
 B) Infinity
 C) Principle Focus
 D) Near Point

Q.15 Mathematical formula of maximum velocity (v_0) for a body executing simple harmonic motion is:

- A) $v_0 = \omega x_0$
 B) $v_0 = \frac{k}{m} \sqrt{x^2 - x_0^2}$
 C) $v_0 = \omega \sqrt{1 - \frac{x^2}{x_0^2}}$
 D) $v_0 = \omega \sqrt{x_0^2 - x^2}$

Q. 16 A body is having weight 20 N, when the elevator is descended with $a = 0.1 \text{ ms}^{-2}$, then the value of tension 'T' is:

- A) 196 N
 B) 19.8 N
 C) 1.98 N
 D) 2 N

Q.17 Sodium 24 has half-life of 15 hour and it is used in medicine to estimate:

- A) Kidney Function
 B) Plasma Blood Volume
 C) Iron in Plasma
 D) Thyroid Function

Q.18 The unit of temperature in base unit is:

- A) Celsius
 B) Degree
 C) Kelvin
 D) Fahrenheit

Q.19 The dimensions of pressure is:

- A) $[M^{-1}L^2T^{-2}]$
 B) $[ML^{-1}T]$
 C) $[M^{-1}L^{-2}T^{-2}]$
 D) $[ML^{-1}T^{-2}]$

Q.20 In Wilson Cloud Chamber which of the following tracks represented β -particles?

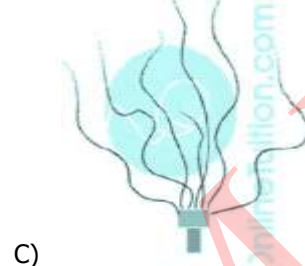
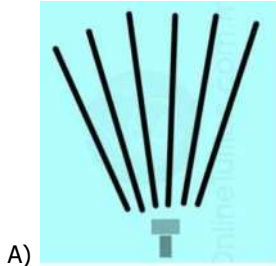

A)

C)

B)

Q.21 Mass flow per unit area of the fluid is given by:

- A) ρv
 B) $\frac{\rho}{v}$
 C) $\frac{Av}{\rho}$
 D) $\frac{Av}{\rho}$

Q.22 The dimension of coefficient of viscosity is:

- A) $[M^{-2}L^{-1}T^{-1}]$
 B) $[ML^{-2}T^{-1}]$
 C) $[ML^{-2}T^1]$
 D) $[ML^{-1}T^{-1}]$

Q.23 What should be the length of simple pendulum whose period is 6.28 second at a place where $g = 10 \text{ ms}^{-2}$.

- A) 0.28 m
 B) 10.8 m
 C) 6.28 m
 D) 10 m

Q.24 What should be the ration of kinetic energy to total energy for simple harmonic oscillator?

- A) $1 - \frac{x^2}{x_0^2}$
 B) 1
 C) $(x_0^2 - x^2)$
 D) $\frac{1}{2} x_2$

Q.25 An observer moves with velocity ' v_0 ' toward a stationary source, then the number of waves received in one second is:

- A) $f' = f \left(\frac{v + v_0}{v} \right)$
 B) $f' = f \left(\frac{v - v_0}{v} \right)$
 C) $f' = f \left(\frac{v + v_0}{v} \right)$
 D) $f' = f \left(\frac{v - v_0}{v} \right)$

Q.26 Strain energy in a deformed energy is stored in the form of:

- A) Elastic Energy
 B) Potential Energy
 C) Plastic Energy
 D) Kinetic Energy

- Q.27** A wire of area of cross section 'A' and original length 'l' is subjected to a load 'L'. A second wire of same material with an area is '2A' and length '2l' is subjected to the same load 'L'. If the extension in first wire is 'X' and second wire is 'Y', find the ratio 'X/Y'.
- A) $\frac{1}{4}$ C) $\frac{1}{1}$
 B) $\frac{1}{2}$ D) $\frac{2}{1}$
- Q.28** Two sample of gases '1' and '2' are taken at same temperature and pressure but the ratio of number of their volume is $V_1:V_2 = 2:3$. What is the ration of number of moles of the gas sample?
- A) 3:2 C) 4:9
 B) $\sqrt{2}:\sqrt{3}$ D) 2:3
- Q.29** Root mean square velocity of a gas having pressure 'P' and density ' ρ ' is given by:
- A) $\sqrt{\frac{3P}{\rho}}$ C) $\sqrt{\frac{3\rho}{P}}$
 B) $\frac{\rho}{3P}$ D) $\frac{3\rho}{P}$
- Q.30** When the rate of gas changes without change in temperature, the gas is said to undergo:
- A) Isothermal Process C) Isochoric Process
 B) Adiabatic Process D) Isobaric Process
- Q.31** What is the 273 k on the Celsius scale of temperature?
- A) 0.15 °C C) -0.15 °C
 B) 273.15 °C D) -273.15 °C
- Q.32** If heat 'Q₁' is absorbed at temperature 'T' and heat 'Q₂' is absorbed at temperature of triple point of water, then unknown temperature of system (in K) is:
- A) 273.16 C) 273.16 Q
 B) 273.16 Q₂/Q₁ D) 273.16 Q₁/Q₂
- Q.33** If the fundamental logic gates are connected as:

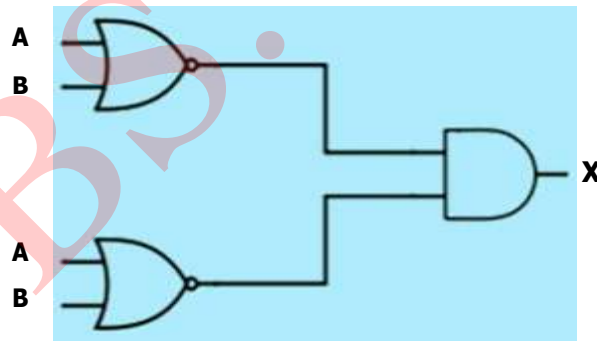

What are the mathematical notation for this logic gate?

- A) $(A - B) \cdot (A + B)$ B) $(A - B)(A + B)$
 C) $(A - B)(A)$ D) $AB + AB$
- Q.34** Which combinations of seven identical resistors each of 2 Ω gives rise to the resultant of 10/11 Ω ?
- A) 5 Parallel, 2 Series C) 3 Parallel, 4 Series
 B) 4 Parallel, 3 Series D) 2 Parallel, 5 Series
- Q.35** If a resistor having resistance 'R' is cut into three equal parts, then the equivalent of parallel combination is:
- A) $\frac{6}{R}$ C) $\frac{R}{9}$
 B) $\frac{3}{R}$ D) $\frac{R}{3}$

Q.50 Which one of the following structures shows the correct formula of glutamic acid?



Q.51 Select the correct Zwitter ionic structures of an amino acid.

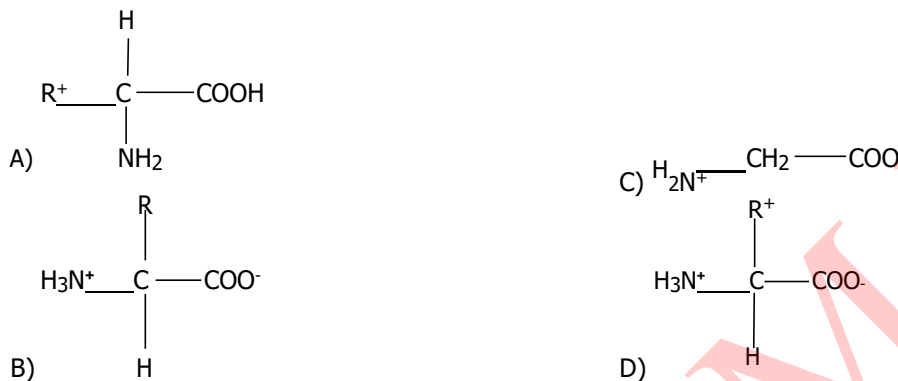

Q.52 How many moles of sodium are present in 0.1 g of sodium?

- A) 4.3×10^{-3}
 B) 4.03×10^{-1}
 C) 4.01×10^{-2}
 D) 4.3×10^{-2}

Q.53 The structural formula for alanine is:

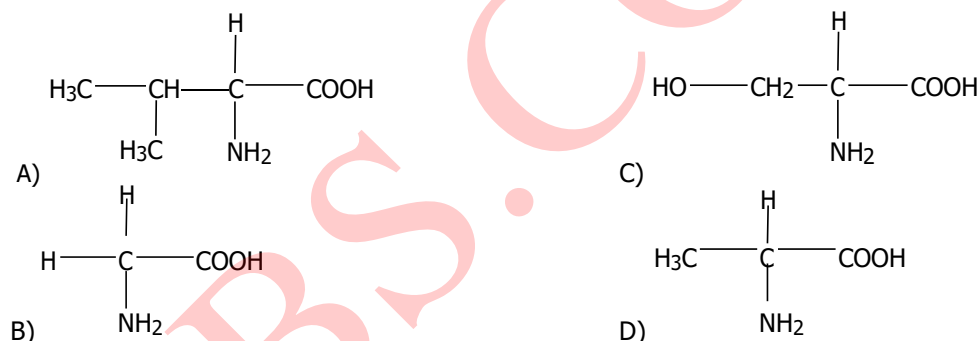

Q.54 With the help of spectral data given calculate the mass of Neon and encircle the best option. (Percentage of $^{10}\text{Ne}^{20}$, $^{10}\text{Ne}^{21}$ and $^{10}\text{Ne}^{22}$ are 90.92%, 0.26% and 8.82% respectively).

- A) 22.18 amu
 B) 21.18 amu
 C) 20.18 amu
 D) 22.20 amu

Q.55 Which one of the following pairs has the same electronic configuration as possessed by Neon (Ne-10)?

- A) Na^+ , Cl^-
 B) K^+ , Cl^-
 C) Na^+ , Mg^{2+}
 D) Na^+ , F^-

Q.56 If the volume of a gas collected at a temperature of 600 °C and pressure of $1.05 \times 10^5 \text{ Nm}^{-2}$ is 60 dm^3 , what would be the volume of gas at STP ($P=1.01 \times 10^5 \text{ Nm}^{-2}$, $T = 273 \text{ K}$)?

- A) 25 cm^3
 B) 75 cm^3
 C) 100 cm^3
 D) 51 cm^3

Q.57 There are four orbitals s, p, d and f. Which order is correct with respect to the increasing energy of the orbitals?

- A) $4s < 4p < 4d < 4f$
 B) $4p < 4s < 4f < 4d$
 C) $4s < 4f < 4p < 4d$
 D) $4f < 4s < 4d < 4p$

Q.58 Which graph represents Boyle's law?

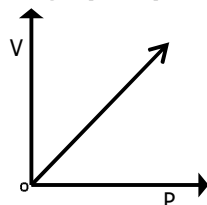

A)

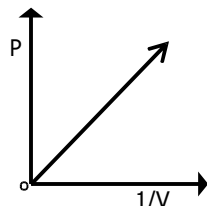

B)

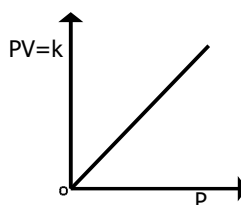

C)

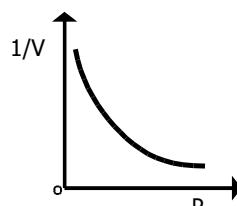

D)

Q.59 Which one of the following hydrogen bonds is stronger than others?

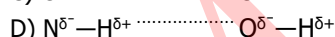
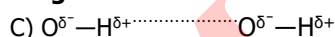
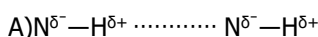

Q.60 The half-life of N_2O_5 at 0°C is 24 minutes. How long will it take for sample of N_2O_5 to decay to 25% of its original concentration?

A) 24 minutes

B) 72 minutes

C) 120 minutes

D) 48 minutes

Q.61 When the change in concentration is $6 \times 10^{-4} \text{ mol dm}^{-3}$ and time for that change is 10 seconds, the rate of reaction will be

A) $6 \times 10^{-3} \text{ mol dm}^{-3} \text{ sec}^{-1}$ B) $6 \times 10^{-4} \text{ mol dm}^{-3} \text{ se}^{-1}$ C) $6 \times 10^{-2} \text{ mol dm}^{-3} \text{ sec}^{-1}$ D) $6 \times 10^{-5} \text{ mol dm}^{-3} \text{ sec}^{-1}$

Q.62 Which one of the following will have the smallest radius?

A) Al^{+3} B) Si^{+4} C) Mg^{+2} D) Na^{+1}

Q.63 Keeping in view the size of atoms, which order is correct?

A) $\text{N} > \text{C}$ B) $\text{P} > \text{Si}$ C) $\text{Ar} > \text{Cl}$ D) $\text{Li} > \text{Be}$

Q.64 On the basis of oxidizing power of halogens, which reaction is possible?

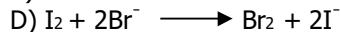
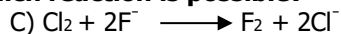

Q.65 Which one of the following gases is used as mixture for breathing by sea divers?

A) Oxygen and Nitrogen

B) Nitrogen and Helium

C) Helium and Oxygen

D) Helium and Hydrogen

Q.66 $[\text{Ti}(\text{H}_2\text{O})_6]^{+3}$ transmits

A) Yellow and Red light

B) Yellow and Blue light

C) Red and white light

D) Red and blue light

Q.67 Electronic configuration of Gold $[\text{Au}79]$ is

A) $[\text{Xe}] 4f^{14}, 5d^{10}, 6s^1$ B) $[\text{Xe}] 4f^{10}, 5d^{10}, 6s^2$ C) $[\text{Xe}] 4f^{14}, 5d^9, 6s^2$ D) $[\text{Xe}] 4f^{14}, 5d^{10}, 6s^2$

Q.68 About 80% of ammonia is used for the production of

A) Explosives

B) Fertilizers

C) Nylon

D) Polymers

Q.69 Urea is the most widely used nitrogen fertilizer in Pakistan. Its composition is

- A) NH_2CO C) $\text{N}_2\text{H}_4\text{CO}_2$
 B) $\text{N}_2\text{H}_5\text{CO}_2$ D) $\text{N}_2\text{H}_4\text{CO}$

Q.70 During the manufacture of nitric acid, nitric oxide is oxidized to nitrogen dioxide. This reaction is given as:



According to Le Chatelier's Principle

- A) Reaction must not be temperature dependent C) Reaction must be carried out at low temperature
 B) Reaction must be carried out at room temperature D) Reaction must be carried out at high temperature

Q.71 What is the percentage of nitrogen in NH_3NO_3 ?

- A) 65% C) 20%
 B) 35% D) 58%

Q.72 The structural formula of 2,3,4 trimethylpentane is:

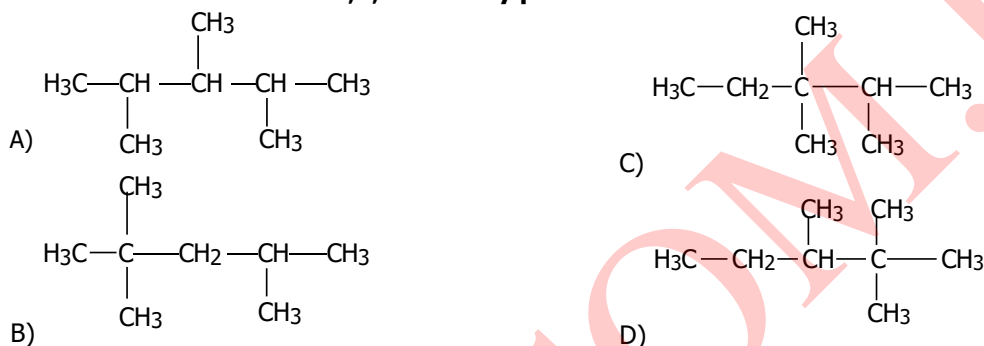

Q.73 Which one of the following is a powerful electrophile used to attack on the electrons of benzene ring?

- A) FeCl_2 C) Cl^+
 B) FeCl_4^- D) Cl_2

Q.74 Order of reactivity of alkenes with hydrogen halide is:

- A) $\text{HBr} > \text{HI} > \text{HCl}$ C) $\text{HF} > \text{HI} > \text{HCl}$
 B) $\text{HI} > \text{HBr} > \text{HF}$ D) $\text{HI} > \text{HBr} > \text{HCl}$

Q.75 The given three hydrocarbons are



Benzene

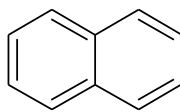

Naphthalene

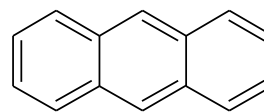

Anthracene

- A) Alicyclic hydrocarbons C) Acyclic Hydrocarbons
 B) Aromatic hydrocarbons D) Heterocyclic hydrocarbons

Q.76 The IUPAC name of the given compound is

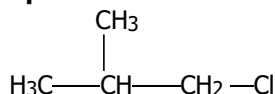

- A) 1-Chloro-2-methylpropane C) Isobutyl chloride
 B) 1-Chloro-2-methylbutane D) 2-Methyl-3-chloropropane

Q.77 Which one of the following was used as one of the earliest antiseptic and disinfectant?

- A) Phenol C) Ethanol
 B) Ether D) Methanol

Q.78 Which one of the following is NOT able to denature the ethanol?

- A) Methanol C) Pyridine
 B) Lactic acid D) Acetone

Q.79 In the below reaction, the configuration of product is

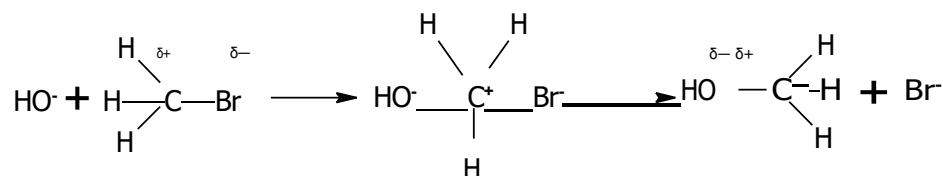

- A) 100% same of the configuration of reactant
 B) 50% retained
 C) 50% inverted
 D) 100% opposite from configuration of reactant

Q.80 How will you distinguish between methanol and ethanol?

- A) By Lucas test
 B) By silver mirror test
 C) By oxidation
 D) By Iodoform test

Q.81 To produce absolute alcohol (100%) from rectified spirit (95.6% alcohol), the remaining 4.4% water must be removed by a drying agent such as

- A) Calcium oxide
 B) Calcium chloride
 C) Calcium carbonate
 D) Carbon monoxide

Q.82 Which one of the following is also called silver mirror test?

- A) Fehling's solution test
 B) Iodoform test
 C) Tollen's reagent
 D) Benedict's solution tests

Q.83 When acetaldehyde reacts with 2,4-dinitrophenylhydrazine (2,4-DNPH), which one of the following products is formed?

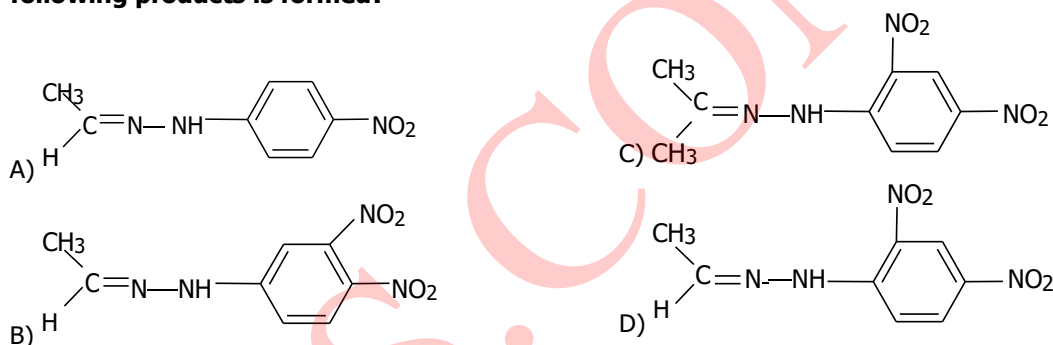

Q.84 Both aldehydes and ketones are planer to the neighborhoods of carbonyl (C=O) group. Which one of the following bonds is distorted towards the oxygen atoms?

- A) π -bond of C and O
 B) Sigma bond of C and H
 C) Sigma bond of C and O
 D) Sigma bond of C and C

Q.85 In $\overset{4}{\text{CH}_3}-\overset{3}{\underset{\text{CH}_3}{\text{CH}}}-\overset{2}{\underset{\text{CH}_3}{\text{CH}}}-\overset{1}{\text{COOH}}$ which one is α -carbon atom?

- A) 1
 B) 3
 C) 2
 D) 4

Q.86 The specific substances (metabolite) that fits on the enzyme surface and is converted to products is called

- A) Co-factor
 B) Prosthetic group
 C) Isoenzyme
 D) Substrate

Q.87 Polyimide is formed due to the condensation of hexane-dioic acid with

- A) Hexane-1,5-diamine
 B) Hexane-1,6-diamine
 C) Hexane-1,4-diamine
 D) Hexane-2,5-diamine

Q.88 Haemoglobin is a

- A) Genetic protein
 B) Building protein
 C) Transport protein
 D) Structural protein

Q.100 Keeping in mind the electrode potential, which one of the following reactions is feasible?

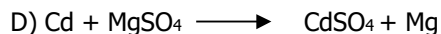
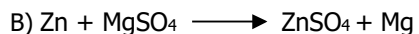
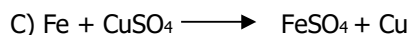
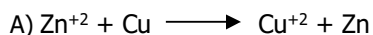

Q.101 What is the correct relation between pH and pK?

A) $pH = pK_a + \log\left[\frac{\text{Acid}}{\text{Base}}\right]$

C) $pH = pK_a - \log\left[\frac{\text{Base}}{\text{Acid}}\right]$

B) $pH = pK_a - \log\left[\frac{\text{Acid}}{\text{Base}}\right]$

D) $pH = pK_a + \log\left[\frac{\text{Base}}{\text{Acid}}\right]$

Q.102 Which one of the following is the correct presentation for K_{sp} ?

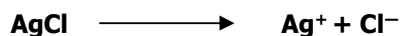

A) $K_{sp} = \frac{[AgCl]}{[Ag^{+1}][Cl^{-1}]}$

C) $K_{sp} = \frac{[Ag^{+1}][Cl^{-1}]}{[AgCl]}$

B) $K_{sp} = [Ag^{+1}][Cl^{-1}]$

D) $K_{sp} = [AgCl]$

ENGLISH

Q.103 In spite of all the torture, the police has failed to _____ any confession from the thief.

- A) Convince
B) Elicit

- C) Refuse
D) Agree

Q.104 It is the duty of a teacher to _____ moral values in his students besides teaching.

- A) Tell
B) Record

- C) Inculcate
D) Suggest

Q.105 Many of the houses in Murree have basic _____

- A) Amenities
B) Accuracy

- C) Affinity
D) Array

Q.106 Youngsters who indulge in love affairs are usually _____ in worldly manners.

- A) Adjoined
B) Addled

- C) Adjured
D) Adhesive



SPOT THE ERROR: In the following sentences, some segments of each sentence are underlined. Your task is to identify that underlined segment of the sentence, which contains the mistake that needs to be corrected. Fill the Circle corresponding to that letter under the segment in the MCQ Response Form.

Q.107 He picked up one or two magazines and after a hurried glance on the contents carefully replaced them.

- A) B) C) D)

Q.108 His guests found it fun to watch him to make tea - mixing careful spoonful from different caddies.

- A) B) C) D)

Q.109 You have put your life in his hands many a times.

- A) B) C) D)

Q.110 Chips, thinking it over a good many time, always added to himself that Kathie would have approved and also have been amused.

- A) B) C) D)

Q.111 But the men ate their supper in good appetites.

- A) B) C) D)

- Q.112** A common sense of failure is a mistaken ambition of the boys on the part of his parents.
A) B) C) D)

⇒ **In each of the following question, four alternative sentences are given. Choose the CORRECT one and fill the Circle corresponding to that letter in the MCQ Response Form.**

- Q.113**
A) Tourism is burgeoned over the last fifteen years. C) Tourism have burgeoned over the last fifteen years.
B) Tourism will burgeoned over the last fifteen years. D) Tourism has burgeoned over the last fifteen years.
- Q.114**
A) His remains were interred in the new cemetery. C) His remains was interred in the new cemetery.
B) His remains were entered in the new cemetery. D) His remains was entered in the new cemetery.
- Q.115**
A) They had died in the same day. C) They had died on the same day.
B) They had died over the same day. D) They had died of the same day.
- Q.116**
A) She had turned on the supper steaks when the telephone rang.
B) She had turned over the supper steaks when the telephone rang.
C) She had turned into the supper steaks when the telephone rang.
D) She had turned in the supper steaks when the telephone rang.
- Q.117**
A) Empty of concord is the soul of wit. C) Empty of concord is the sole of wit.
B) Empty of concord is the role of wit. D) Empty of concord is the howl of wit.
- Q.118**
A) The cheery trees stand over the woodland ride. C) The cheery trees stand beside the woodland ride.
B) The cheery trees stand about the woodland ride. D) The cheery trees stand on the woodland ride.
- Q.119**
A) He made me to write the sum on the slip and to sign my name in a book.
B) He made me write the sum on/at the slip and to sign my name in a book.
C) He made me to write the sum on the slip and sign my name in a book.
D) He made me to write the sum in a slip and to sign my name in a book.
- Q.120**
A) I am looking forward to secure excellent marks in MCAT.
B) I am looking forward to securing excellent marks in MCAT.
C) I am looking forward securing excellent marks in MCAT.
D) I am looking forward secure excellent marks in MCAT.
- Q.121**
A) The study of population growth indicates one of the greatest paradox of our time.
B) The study of population growth indicate one of the greatest paradox of our time.
C) The study of population growth indicates one of the greatest paradoxes of our time.
D) The study of population growth indicates one of the greatest paradox in our time.
- Q.122**
A) In North Africa, he barely escaped assassination at the hand of the governor of the province.
B) In North Africa, he barely escaped from assassination at the hands of the governor of the province.
C) In North Africa, he barely escaped from assassination at the hand of the governor of the province.
D) In North Africa, he barely escaped assassination at the hands of the governor of the province.

⇒ **In each of the following question, four alternative meanings of a word are given. You have to select the NEAREST CORRECT MEANING of the given word and fill the appropriate Circle on the MCQ Response Form.**

- Q.123** **EMPATHY**
A) Understanding C) Friendship
B) Animosity D) Sympathy

Q.124 FELICITY

- A) Boredom
- B) Business

- C) Happiness
- D) Relaxation

Q.125 UNCANNY

- A) Exact
- B) Opposite

- C) Good
- D) Strange

Q.126 VIRULENT

- A) Progressive
- B) Harmful

- C) Healthy
- D) Positive

Q.127 RAPT

- A) Trumpet
- B) Bewitched

- C) Rapid
- D) Rash

Q.128 PEDAGOGY

- A) The study of pediatrics
- B) The study of teaching methods

- C) The study of cultural heritage
- D) The study of pectoral muscle

Q.129 INDICTMENT

- A) Humiliation
- B) Offended

- C) Accusation
- D) Invisible

Q.130 MITIGATION

- A) Alleviation
- B) Classification

- C) Formidable
- D) Poisonous

Q.131 CONCERTED

- A) Strenuous
- B) Furious

- C) Curious
- D) Precious

Q.132 ARCANE

- A) Mysterious
- B) Furious

- C) Arid
- D) Clear

BIOLOGY

Q.133 In _____ response, β -cells produce plasma cells that synthesize antibodies and release in blood plasma and tissue fluid.

- A) Cell-Mediated
- B) Hormonal

- C) Humoral
- D) Phototactic

Q.134 Passive immunity is used against:

- A) Malaria
- B) Typhoid

- C) Dengue
- D) Tetanus

Q.135 B-lymphocytes are named due to their relationship with:

- A) Blood
- B) Bursa of Fabricius

- C) Bone Marrow
- D) Bile Duct

Q.136 In light independent stage of photosynthesis, the CO_2 combines with _____ to form an unstable 6-carbon intermediate.

- A) Ribulose biphosphate
- B) Hexose sugar

- C) Glycerate-3-phosphate
- D) Glyceraldehyde-9-phosphate

Q.137 In glycolysis, glycerate-1,3-bisphosphate is converted into glycerate-3-phosphate by losing _____ phosphate molecules.

- A) 3
- B) 2

- C) 1
- D) 4

- Q.138 Malate is oxidized by _____ to oxaloacetate in Krebs's Cycle.**
 A) ATP
 B) NADP
 C) NAD
 D) FAD
- Q.139 In electron transport chain, the electrons from NADH and FADH₂ are passed to;**
 A) Cytochrome a
 B) Cytochrome a₃
 C) Co-enzyme c
 D) Co-enzyme Q
- Q.140 Carriers of the respiratory chain are located on:**
 A) Matrix of mitochondria
 B) Outer membrane of mitochondria
 C) Inner membrane of mitochondria
 D) Cytoplasmic matrix
- Q.141 In cystic fibrosis, liposomes-microscopic vesicles are used which are coated with:**
 A) Healthy Gene
 B) Chromosome
 C) Protein
 D) Carbohydrate
- Q.142 The DNA formed by the reverse transcription is called:**
 A) rDNA
 B) dDNA
 C) cDNA
 D) DNA
- Q.143 Bacterial cells take up recombinant plasmids when they are treated with:**
 A) CaCl₂
 B) NaCl
 C) KCl
 D) NaOH
- Q.144 Which one of the following is made up of radioactively labelled nucleotides?**
 A) Phage DNA
 B) Genomic Library
 C) Recombinant DNA
 D) Gene Probe
- Q.145 A technique in transgenic animals in which desired gene is inserted into the eggs of animal is called:**
 A) Embryonic Stem Cell mediated Transfer
 B) Microinjection
 C) Retro-virus mediated gene Transfer
 D) Virus vectors
- Q.146 Ozone is a layer of atmosphere extending from _____ km above earth and absorbs ultraviolet radiations.**
 A) 10-50
 B) 50-60
 C) 5-30
 D) 10-80
- Q.147 Light rays from the sun are absorbed by CO₂ and re-radiate as _____ radiations.**
 A) Ultraviolet
 B) Indigo
 C) Infra-Red
 D) Green
- Q.148 The gases which are produced by burning of fossils fuels and are responsible for acid rain are:**
 A) CFCs
 B) CO₂ and CO
 C) HCl and Oxides of Nitrogen
 D) SO₂ and Oxides of Nitrogen
- Q.149 During successions, the first organisms that develop on bare rock are:**
 A) Lichens
 B) Shrubs
 C) Moss
 D) Herbs
- Q.150 Trophic level of a herbivore in given food-web is:**

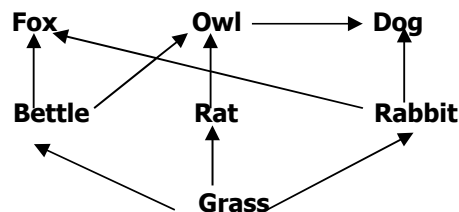

- A) 1
 B) 3
 C) 4
 D) 2

Q.151 During maternal mitosis, non-disjunction of autosomal chromosome pair results in the formation of an egg having 24 chromosomes in:

- A) Klinefelter's Syndrome
- B) Down's Syndrome
- C) Turner's Syndrome
- D) Jacob's Syndrome

Q.152 Typical symptoms like enlarged breasts and small testis in male are attributed to:

- A) Down's Syndrome
- B) Turner's Syndrome
- C) Klinefelter's Syndrome
- D) Phenylketonuria

Q.153 Fluid mosaic model of plasma membrane states that protein molecules float in a fluid layer.

- A) Galactose
- B) Phospholipids
- C) Glucose
- D) Carbohydrate

Q.154 How many triplets of microtubules are present in centriole?

- A) Ten
- B) Eight
- C) Nine
- D) Seven

Q.155 Turner's syndrome is characterized by having:

- A) Trisomy 21
- B) 44 + XXY
- C) Trisomy 18
- D) 44 + XO

Q.156 Which one of the following cell structure is involved in the synthesis of lipids?

- A) Endoplasmic Reticulum
- B) Golgi Complex
- C) Centriole
- D) Mitochondria

Q.157 Monosaccharides are major components of:

- A) DNA, ATP, Ribulose biphosphate and Cysteine
- B) DNA, NAD and Insulin
- C) DNA, NADP, ATP and Ribulose biphosphate
- D) DNA, RNA and Myosin

Q.158 Blood group antigen contains:

- A) Glycoproteins
- B) Phospholipids
- C) Glycolipids
- D) Sphingolipids

Q.159 Myosin is a _____ type of protein.

- A) Intermediate
- B) Simple
- C) Globular
- D) Fibrous

Q.160 Which one of the following is an example of unsaturated fatty acid?

- A) Butyric Acid
- B) Oleic Acid
- C) Palmitic Acid
- D) Acetic Acid

Q.161 Number of base pairs in one turn of DNA is:

- A) 10
- B) 2
- C) 34
- D) 54

Q.162 The lymph vessel of villi is called:

- A) Epithelium
- B) Afferent lymph vessel
- C) Adrenals
- D) Lacteal

Q.163 Right atrium is separated from right ventricle by:

- A) Bicuspid Valve
- B) Semilunar Valve
- C) Tricuspid Valve
- D) Interatrial Septum

Q.164 The flaps of tricuspid valves are attached to muscular extensions of right ventricle known as:

- A) Smooth Muscles
- B) Papillary Muscles
- C) Intercostal Muscles
- D) Skeletal Muscles

Q.165 One complete heart beat consists of one systole and one diastole and lasts for about:

- A) 0.8 sec
- B) 0.2 sec
- C) 0.4 sec
- D) 0.5 sec

Q.166 The heart beat cycle starts when electric impulses are generated from;

- A) AV Node
- B) SV Node
- C) SA Node
- D) PQ Node

- Q.167 About 70-85% CO₂ in blood is carried:**
 A) As carboxylase myoglobin
 B) With proteins in plasma
 C) Freely as CO₂
 D) As bicarbonate
- Q.168 Those nephrons which are present along the border of the cortex and medulla are called:**
 A) Juxtamedullary nephrons
 B) Cortical nephrons
 C) Internal nephrons
 D) Outer nephrons
- Q.169 When water is in short supply, increased water retention occurs through the:**
 A) Cortical nephrons
 B) Proximal Convoluted Tubule
 C) Juxtamedullary nephrons
 D) The tissue of cortex
- Q.170 In nephrons, counter-current multiplier occurs at:**
 A) Loop of Henle
 B) Collecting Duct
 C) Bowman's Capsule
 D) Glomerulus
- Q.171 Ascending loop of Henle does not allow outflow of:**
 A) Na⁺ ions
 B) K⁺ ions
 C) Cl⁻ ions
 D) Water
- Q.172 A larger quantity of dilute urine is produced in diabetes insipidus. This disease is due to the deficiency of:**
 A) Antidiuretic Hormone
 B) Aldosterone
 C) Thyroxine
 D) Cortisol
- Q.173 Water and sodium ions are reabsorbed in:**
 A) Urinary Bladder and Urethra
 B) Ureter
 C) Adrenal Cortex
 D) Proximal Convoluted Tubule & Collecting Duct
- Q.174 Which disease is responsible for dementia (memory loss)?**
 A) Parkinson's Disease
 B) Alzheimer's Disease
 C) Epilepsy
 D) Grave's Disease
- Q.175 Neurotransmitter secreted at synapse outside the central nervous system is:**
 A) Dopamine
 B) Polypeptide
 C) Androgen
 D) Acetylcholine
- Q.176 Conduction of action potentials from one node of Ranvier to another in myelinated neurons is through:**
 A) Hyperpolarization
 B) Resting Membrane Potential
 C) Depolarization
 D) Saltatory Conduction
- Q.177 In the following diagram of action potential in a neuron, 'x' depicts:**

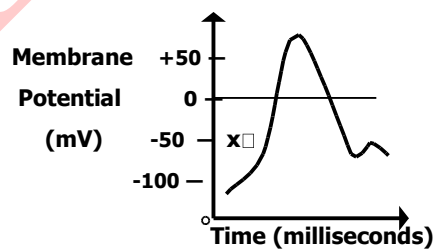

- A) Depolarization
 B) Polarization
 C) Repolarization
 D) Hyperpolarization
- Q.178 In human testis, which structure is responsible for carrying sperm from inside the testis?**
 A) Seminiferous tubules
 B) Urinogenital duct
 C) Seminal Vesicles
 D) Vasa efferentia
- Q.179 In which part of female reproductive system fertilization takes place?**
 A) Proximal part of oviduct
 B) Uterus
 C) Placenta
 D) Vagina

Q.180 In females, FSH stimulates the ovary to produce:

- A) Progesterone
- B) Lactin
- C) Oestrogen
- D) Oxytocin

Q.181 Syphilis, sexually transmitted disease is caused by:

- A) HIV
- B) Treponema pallidum
- C) Neisseria gonorrhoeae
- D) Type '2' virus

Q.182 In which phase of human female menstrual cycle, endometrium prepares for the implantation of embryo?

- A) Proliferative phase
- B) Menstrual phase
- C) Secretory phase
- D) Ovulation phase

Q.183 The total number of cervical and thoracic vertebrate in human vertebral column is:

- A) 7
- B) 19
- C) 14
- D) 33

Q.184 A sarcomere is the region of a myofibril between two successive:

- A) M-lines
- B) Z-lines
- C) I-bands
- D) T-tubules

Q.185 The sarcolemma of muscle fibre folds inwards and forms a system of tubes which runs through the sarcoplasm called:

- A) Myofilaments
- B) Sarcoplasmic reticulum
- C) Z-lines
- D) Transverse tubules

Q.186 According to sliding filament theory, when muscle fibers are stimulated by nervous system, which of the following changes occurs?

- A) I-bands shorten
- B) H-zone becomes more visible
- C) Z-lines move further apart
- D) A-bands shorten

Q.187 If lactic acid build up in thigh muscles, it causes muscle tiredness and pain. This condition is called:

- A) Muscle Fatigue
- B) Tetany
- C) Cramps
- D) Oxygen debt in muscles

Q.188 Thyroxine deficiency in adults' results in a condition called:

- A) Cretinism
- B) Hypothyroidism
- C) Thyrotoxicemia
- D) Myxoedema

Q.189 α -cells of pancreas secrete a hormone known as:

- A) Glucagon
- B) Insulin
- C) Gastrin
- D) Rennin

Q.190 X-linked recessive trait is:

- A) Hypophosphatemia
- B) Vitamin-D resistant rickets
- C) Haemophilia
- D) Diabetes Mellitus

Q.191 Human skin colour is a good example of?

- A) Sex-linked inheritance
- B) Polygenic inheritance
- C) x-linked inheritance
- D) y-linked inheritance

Q.192 From evolutionary point of view, which respiratory protein is common in many organisms?

- A) Cytochrome a
- B) Cytochrome b
- C) Cytochrome c
- D) Cytochrome d

Q.193 Number of pairs of autosomes in humans in:

- A) 23
- B) 24
- C) 21
- D) 22

Q.194 ABO blood system is an example of:

- A) Polygenes
- B) Multiple genes
- C) Multiple Alleles
- D) Multiple Mutation

- Q.195 Which molecular structure of enzyme is essential for activity of enzyme?**
A) Primary Structure
B) Quaternary Structure
C) Secondary Structure
D) Tertiary Structure
- Q.196 Which one of the following edible products is widely pasteurized?**
A) Soft drinks
B) Mango squash
C) Milk
D) Orange Juice
- Q.197 Ribosomes are tiny organisms, which are involved in the synthesis of:**
A) Protein
B) RNA
C) Nucleus
D) Nucleosome
- Q.198 Which organelle is bounded by two membranes?**
A) Ribosome
B) Mitochondria
C) Lysosome
D) Nucleolus
- Q.199 At the beginning of nuclear division, the number of microtubule triplets in two pairs of centrioles that migrate to opposite poles are:**
A) 9
B) 18
C) 108
D) 36
- Q.200 The disease in which an individual has extra sex chromosome (44 + XXY) is known as:**
A) Down's syndrome
B) Turner's syndrome
C) Klinefelter's syndrome
D) Jacob's syndrome
- Q.201 Over-secretion of cortical hormone causes a disease called;**
A) Cushing's Disease
B) Diabetes Mellitus
C) Hypoglycemia
D) Addison's Disease
- Q.202 Ejection of milk from mammary glands is under the control of which one of the following hormones?**
A) Androgen
B) Oxytocin
C) Progesterone
D) Estrogen
- Q.203 Granulocytes are:**
A) Monocytes, Eosinophils, Basophils
B) Basophils, Macrophages, Neutrophils
C) Neutrophils, Eosinophils, Basophils
D) Monocytes, Macrophages, Basophils
- Q.204 Response of body against the transplanted organ is:**
A) Homeostatic Response
B) Behavioral Response
C) Primary Response
D) Cell-mediated Response
- Q.205 Some enzymes require helper which is non-protein part for its efficient functioning that is called:**
A) Accelerator
B) Cofactor
C) Prosthetic group
D) Apoenzyme
- Q.206 Pepsin, protein digesting enzymes, sets best pH:**
A) 3.00
B) 4.50
C) 2.00
D) 6.00
- Q.207 Which one of the following is an example of competitive inhibitor?**
A) Glucose
B) Fumerate
C) Succinic Acid
D) Melonate
- Q.208 HIV is classified as:**
A) Bacteriophage
B) Oncovirus
C) Retrovirus
D) Icosahedral virus
- Q.209 Cyanobacteria are:**
A) Photoautotrophic bacteria
B) Chemosynthetic bacteria
C) Saprotrophic bacteria
D) Parasitic bacteria

- Q.210 During favourable conditions, certain bacteria produces:**
A) Ribosomes
B) Plasmids
C) Mitochondria
D) Spores
- Q.211 In rhizopus, zygote forms temporary, dormant, thick-walled resistant structure called:**
A) Zygospore
B) Spore
C) Sporangia
D) Hydra
- Q.212 _____ is a triploblastic organism.**
A) Jelly Fish
B) Sea Anemone
C) Tapeworm
D) Corals
- Q.213 In arthropods, the body cavity is in the form of:**
A) Coelem
B) Haemocoel
C) Pseudocoelom
D) Enteron
- Q.214 _____ is a good example of polymorphism.**
A) Hydra
B) Starfish
C) Obelia
D) Euplectella
- Q.215 Name common gut roundworm parasite of human and pigs.**
A) Ascaris lumbricoides
B) Lumbricus terrestris
C) Pheretima posthuma
D) Hirudo Medicinalis
- Q.216 _____ is also called liver fluke.**
A) Dugesia
B) Taenia
C) Fasciola
D) Coral
- Q.217 Oxyntic cells in stomach produces:**
A) Pepsin
B) Pepsinogen
C) Gastrin
D) HCl
- Q.218 The hormone which inhibits the secretion of pancreatic juice is:**
A) Secretin
B) Gastrin
C) Thyroxine
D) Parathormone
- Q.219 Trypsinogen is activated to trypsin by:**
A) HCl
B) Enterokinase
C) Mucus
D) Gastrin
- Q.220 The emulsification of fats is the role of:**
A) Saliva
B) Pancreatic juice
C) Gastrin
D) Bile

MBBS.COM.PK

UHS MDCAT PAST PAPERS
BOOK Hard Copy Available
Now.

MBBS.COM.PK
EDUCATION SYSTEM

MDCAT GUIDE
UHS ENTRY TEST

MDCAT

PAST PAPER 2008-2019

- UNIT-WISE SOLVED MCQ's
- HIGHLIGHT REPEATED MCQ's
- CHANGING THE WAY YOU THINK
- BEST SOURCE TO GET HIGH MARKS
- UPDATED EDITION 2020
- AS PER UHS SYLLABUS

START
ENTRY TEST
PREPARATION
2020

LIVE CHAT
0304-7418334

Rs. 1400/=

Free Home Delivery

TO Book Order For MDCAT Past Papers
Call Or WhatsApp 0304-7418334

University of Health Sciences, Lahore



Total MCQs: 220

Max. Marks: 1100

ENTRANCE TEST - 2016

For F.Sc. and Non-F.Sc. Students
Time Allowed: 150 minutes

Instructions:

- Read the instructions on the MCQs Response Form carefully.
- Choose the **Single Best Answer** for each question.
- Candidates are strictly prohibited from giving any identification mark except Roll No. & Signature in the specified columns only.

COMPULSORY QUESTION FOR IDENTIFICATION

Q-ID. What is the color of your Question Paper?

A) White.

C) Pink.

B)

Blue.

D) Green.

ID

Ans: Colour of your Question Paper is Pink.
Fill the Circle Corresponding to Letter 'C'
against 'ID' in your MCQ response form
(Exactly as shown in the diagram).

	A	B	C	D
1	<input type="radio"/>	<input type="radio"/>	<input checked="" type="radio"/>	<input type="radio"/>
2	<input type="radio"/>	<input type="radio"/>	<input type="radio"/>	<input type="radio"/>
3	<input type="radio"/>	<input type="radio"/>	<input type="radio"/>	<input type="radio"/>
4	<input type="radio"/>	<input type="radio"/>	<input type="radio"/>	<input type="radio"/>

PHYSICS

Q.1 Which of the following graph represents the output of an X-ray?

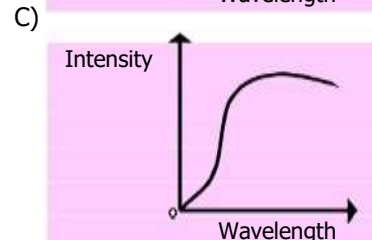
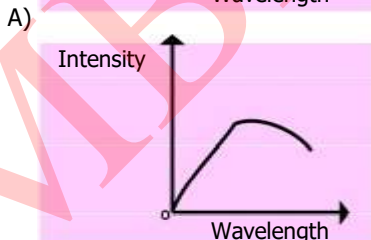
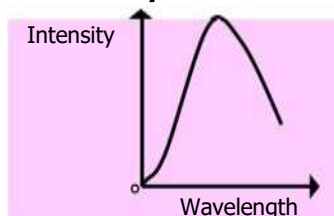
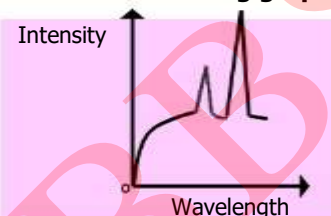

Q.2 The continuous spectrum of X-ray is formed due to:

- A) Characteristics of X-rays
B) Bremsstrahlung X-ray

- C) Soft X-ray
D) Hard X-ray

Q.3 Wavelength of γ -rays is:

- A) Equal to the X-rays
B) Longer to the X-rays

- C) Shorter to the X-rays
D) Boarder to the X-rays

Q.4 Thorium is transformed after the transmission of β -particle into:

- A) Bismuth
 B) Protactinium
 C) Polonium
 D) Palladium

Q.5 Emission of γ -rays from radioactive element results into:

- A) Bismuth
 B) Protactinium
 C) Polonium
 D) Palladium

Q.6 The relation between decay constant ' λ ' and half-life ' $T_{1/2}$ ' of radioactive substance is:

- A) $\lambda = \frac{1}{T_{1/2}}$
 B) $\lambda = 0.693 T_{1/2}$
 C) $\lambda = T_{1/2}$
 D) $\lambda = \frac{0.693}{T_{1/2}}$

Q.7 Radioisotope which is used to combat cancer of thyroid gland is:

- A) Iodine-131
 B) Phosphorous-32
 C) Strontium-90
 D) Cobalt-60

Q.8 Sodium-24 is used for:

- A) Sterilization
 B) Study of circulation of blood
 C) Skin Cancer
 D) Thyroid Cancer

Q.9 Energy radiation absorbed at the rate of one joule per kilogram is called:

- A) 1 Rad
 B) 1 Sievert
 C) 1 Yellow
 D) 1 Gray

Q.10 The time period ' T ' of a simple pendulum depends on its length ' l ' and acceleration due to gravity ' g ' using unit dimension. The correct equation for time period is:

- A) $T = k \sqrt{\frac{l}{g}}$ where 'k' is constant
 B) $T = \frac{1}{k} \sqrt{\frac{l}{g}}$ where 'k' is constant
 C) $T = k \sqrt{\frac{l}{g}}$ where 'k' is constant
 D) $T = \frac{1}{k} \sqrt{\frac{l}{g}}$ where 'k' is constant

Q.11 The unit for electric charge is Coulomb and one Coulomb in terms of base unit is equivalent to:

- A) Am
 B) Js⁻¹
 C) As
 D) C

Q.12 A man in elevator ascending with an acceleration will conclude that his weight is:

- A) Increased
 B) Decreased
 C) Reduced to zero
 D) Remain Constant

Q.13 If we double the moment arm the value of torque becomes:

- A) Half
 B) Three-times
 C) Two-times
 D) Four-times

Q.14 When fluid is incompressible, the quantity is constant is:

- A) Mass
 B) Density
 C) Pressure
 D) Force

Q.15 The minimum distance from the eye at which an object appears to be distant is:

- A) 25 cm
 B) 22 cm
 C) 35 cm
 D) 20 cm

Q.16 Using the relation for the magnifying power L_o , $M = 1 + d/f$, if $f = 5$ cm and $d = 25$ cm then M will be:

- A) 5
 B) 7
 C) 6
 D) 8

Q.17 Resonance occurs when the driving frequency is:

- A) Greater than natural frequency
 B) Unequal the natural frequency
 C) Less than natural frequency
 D) Equal to the natural frequency

- Q.18 The red shift measurement of Doppler effect of galaxies indicate that the universe is:**
 A) Expanding
 B) Contracting
 C) Stationary
 D) Oscillating
- Q.19 Frequency audible range to human hearing lies in the range:**
 A) 2-2000 kHz
 B) 15-50000 kHz
 C) 20-20000 Hz
 D) 20-20000 kHz
- Q.20 Tuning a radio is a best example of:**
 A) Natural resonance
 B) Mechanical resonance
 C) Free resonance
 D) Electrical resonance
- Q.21 The ratio of applied stress to the volumetric strain is called:**
 A) Bulk Modulus
 B) Shear Modulus
 C) Tensile modulus
 D) Young's Modulus
- Q.22 The wire made of copper belong to which specific kind of material:**
 A) Ductile material
 B) Tough material
 C) Brittle material
 D) Deformed material
- Q.23 The relation R
 $N_A = 1.38 \times 10^{-23} \text{ J/K}$ in a gas law is known as:**
 A) Avogadro's constant
 B) Charles constant
 C) Newton's constant
 D) Boltzmann's constant
- Q.24 The relation 'PV = nRT' shows which law of physics:**
 A) Charles Law
 B) Avogadro's Law
 C) Newton's Constant
 D) Ideal Gas Law
- Q.25 The rapid escape of air from a burst tyre is an example of:**
 A) Adiabatic processes
 B) Isothermal process
 C) Cooling process
 D) First law of thermodynamics
- Q.26 Which relation exactly described the isothermal process?**
 A) $Q = W$
 B) $W = \Delta U$
 C) $Q = \Delta U$
 D) $Q = \Delta U + W$
- Q.27 If a turbine is working as a heat engine and takes that from hot body (427 °C) and exhausts into a body at 77 °C then what is the possible efficiency?**
 A) 50%
 B) 70%
 C) 90%
 D) 95%
- Q.28 Which one of the following is the Boolean expression of NAND gate?**
 A) $X = A \cdot B$
 B) $X = A + B$
 C) $X = A \cdot \bar{B}$
 D) $X = \bar{A} + \bar{B}$
- Q.29 Which one of the following is the truth table of NAND gate?**
- A)
- | A | B | Y |
|---|---|---|
| 0 | 0 | 1 |
| 0 | 1 | 0 |
| 1 | 0 | 0 |
| 1 | 1 | 0 |
- B)
- | A | B | Y |
|---|---|---|
| 0 | 0 | 1 |
| 0 | 1 | 1 |
| 1 | 0 | 1 |
| 1 | 1 | 0 |
- C)
- | A | B | Y |
|---|---|---|
| 0 | 1 | 1 |
| 1 | 1 | 0 |
- D)
- | A | B | Y |
|---|---|---|
| 0 | 0 | 0 |
| 1 | 1 | 1 |
- Q.30 If the length, width and separation between the plates of a parallel plate capacitor is doubled then its capacitance becomes:**
 A) Double
 B) Half
 C) Four-times
 D) Eight-times

Q.31 Resistance between two opposite faces of square thin film of area 1 mm^2 having thickness of $1 \text{ }\mu\text{m}$ if resistivity of material is $10^{-6} \Omega$ will be:

- A) 1000Ω C) 1Ω
 B) 100Ω D) 10Ω

Q.32 Total resistance between 'A' and 'B' in the given circuit is:

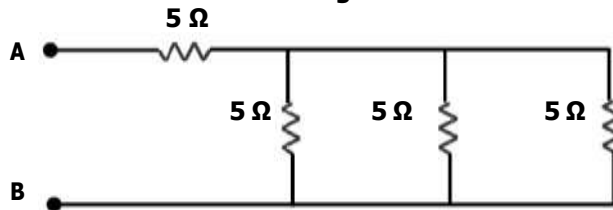

- A) 5.6Ω C) 0.33Ω
 B) 3.33Ω D) 6.6Ω

Q.33 'F' is maximum force acting on a conductor. Now if we change the direction of conductor by making an angle of 45° with the magnetic field then the force becomes:

- A) $\frac{F}{2}$ C) $\frac{F}{\sqrt{2}}$
 B) $2F$ D) $\sqrt{2} F$

Q.34 If we doubled all the parameters of the force acting on current carrying conductor and $\theta = 90^\circ$ then magnetic force becomes:

- A) Half C) Eight-times
 B) Double D) Four-times

Q.35 The force acting on current carrying conductor will be maximum if the angle between magnetic field and conductor is:

- A) 0° C) 90°
 B) 30° D) 60°

Q.36 The shadow of the bones in X-rays photographic film appears lighter than the surrounding flesh due to:

- A) Bones reflect greater amount of X-rays C) Bones absorb greater amount of X-rays
 B) Bones absorb less amount of X-rays D) Bones totally reflect X-rays

Q.37 The atom is excited to an energy level E_i from its ground state energy level E_0 , the wavelength of the radiations emitted is:

- A) $\frac{(E_0 - E_i)}{hc}$ C) $(E_i - E_0)$
 B) $\frac{(E_i - E_0)}{hc}$ D) $\frac{E_i}{hc} - \frac{E_0}{hc}$

Q.38 Which one of the following gas is the lasing or active medium in the laser tube?

- A) Hydrogen C) Neon
 B) Helium D) Carbon dioxide

Q.39 The target of X-ray tube is made up of which metal?

- A) Iron C) Brass
 B) Nickel D) Tungsten

Q.40 The X-rays consists of:

- A) High energy proton C) High energy γ -rays
 B) High energy electrons D) High energy photons

Q.41 In Bernoulli's equation the term $\frac{1}{2} \rho v^2$ is called:

- A) K.E. per unit volume C) K.E. per unit area
 B) K.E. D) K.E. per unit length

Q.42 Potential energy per unit volume is given by:

- A) $\frac{mgh}{\rho}$ C) gh
 B) $\frac{mgh}{\rho}$ D) ρgh

Q.43 If general equation for destructive interference's is given by the relation,

$$\text{Optic path difference} = \left(m + \frac{1}{2}\right) \lambda$$

where 'm' is an integer, then first dark fringe appears from 'm' will be equal to:

- A) $\frac{1}{2}$ C) 0
 B) $\frac{1}{2}$ D) 1

Q.44 For bright fringe formation, the path difference is:

- A) $\left(n + \frac{1}{2}\right) \lambda$ where $n = 0, 1, 2, \dots$ C) $(2n + 1) \frac{\lambda}{2}$ where $n = 0, 1, 2, \dots$
 B) $n\lambda$ where $n = 0, 1, 2, \dots$ D) $\left(\frac{n+1}{2}\right) \lambda^2$ where $n = 0, 1, 2, \dots$

CHEMISTRY

Q.45 Which one of the following is structural formula of proline?

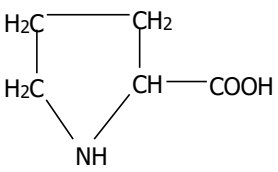
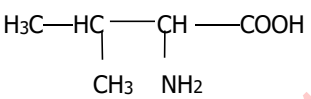
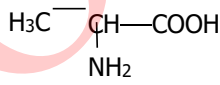
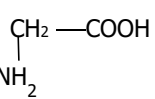
- A) 
 B) 
 C) 
 D) 

Q.46 In the formation of Zwitter ion which one of the following donates the proton?

- A) COOH C) CH_2COO^-
 B) NH_2 D) OH^-

Q.47 

What is the name of above given structural formula?

- A) Aspartic Acid C) Adipic Acid
 B) Asparagine D) Glutamic Acid

Q.48 Which one of the following is simplest amino acid?

- A) Lysine C) Alanine
 B) Leucine D) Glycine

Q.49 Which one of the following polymer is called as Nylon 6,6?

- A) Polyester C) Polyamide
 B) Polyvinyl chloride D) Polyvinyl acetate

Q.50 Which one of the following is an exact composition of a carbohydrates?

- A) Carbon and Hydrogen C) Carbon, Hydrogen and Oxygen
 B) Carbon and Oxygen D) Hydrogen and Oxygen

Q.51 Which one of the following nitrogen base is NOT present in DNA?

- A) Adenine C) Uracil
 B) Guanine D) Cytosine

Q.52 In the woody parts of trees, the %age of cellulose is:

- A) 50%
 B) 10%
 C) 30%
 D) 100%

Q.53

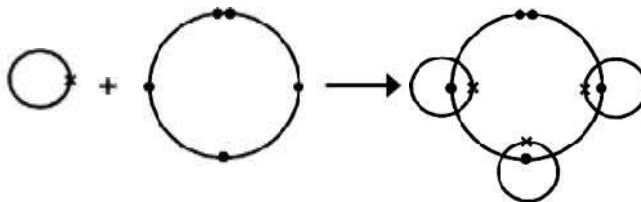

Choose the right molecule.

- A) CH₃
 B) CO
 C) H₂O
 D) NH₃

Q.54

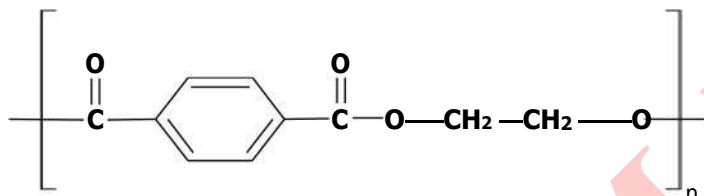

Indicate the name of above given structure.

- A) Nylon 6,6
 B) Adipic Acid
 C) PVA
 D) Polyester

Q.55 In laboratory experiment an unknown compound was added in test tube containing iodine, the colour became intense blue. What could be the unknown compound?

- A) Cellulose
 B) Raffinose
 C) Ribose
 D) Starch

Q.56 Ozone concentration is measured in:

- A) Debye units
 B) Dupont units
 C) Debye units
 D) Dobson units

Q.57 The gas which is mainly produced in landfills from the waste is:

- A) CH₄
 B) CO₂
 C) SO₂
 D) Cl₂

Q.58 The substance for the separation of isotopes is firstly converted into the:

- A) Neutral state
 B) Free state
 C) Vapour state
 D) Charged state

Q.59 The number of moles of CO₂ which contain 8.00 gm of oxygen is:

- A) 0.75
 B) 1.50
 C) 0.25
 D) 1.00

Q.60 London dispersion forces are the only forces present among the:

- A) Molecules of H₂O in liquid state
 B) Molecules of HCl gas
 C) Atoms of helium in gaseous state at high temperature
 D) Molecules of solid chlorine

Q.61 Electrical conductivity of graphite is greater in one direction than in other due to:

- A) Isomorphism
 B) Cleavage plane
 C) Anisotropy
 D) Symmetry

Q.62 Number of neutrons in ⁶⁶Zn will be:

- A) 30
 B) 35
 C) 38
 D) 36

Q.63 The maximum number of electrons in electronic configuration can be calculated by using formula:

- A) 2l + 1
 B) 2n² + 2
 C) 2n²
 D) 2n² + 1

Q.64

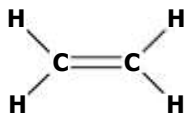

Calculate the number of σ bonds and π bonds in the molecule.

- A) 1π and 5σ bonds
 B) 2π and 4σ bonds
 C) 3π and 3σ bonds
 D) 6π and 6σ bonds

Q.65



In this reaction, ΔH will be called:

- A) Enthalpy of atomization
 B) Enthalpy of decomposition
 C) Enthalpy of formation
 D) Enthalpy of the dissociation

Q.66

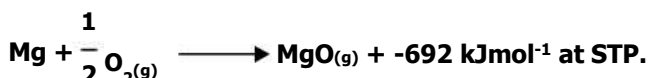

Enthalpy of the above reaction will be called:

- A) $\Delta H^{\circ}_{\text{at}}$
 B) $\Delta H^{\circ}_{\text{s}}$
 C) $\Delta H^{\circ}_{\text{sol}}$
 D) $\Delta H^{\circ}_{\text{f}}$

Q.67

Freezing point will also be defined as that temperature at which its solid and liquid phases have the same:

- A) Concentration
 B) Ratio between the particles
 C) Vapour pressure
 D) Attraction between the phases

Q.68

What mass of NaOH is present in 0.5 mol of sodium hydroxide?

- A) 40 gm
 B) 2.5 gm
 C) 15 gm
 D) 20 gm

Q.69



The diagram shows a galvanic cell. The current will flow from:

- A) Hydrogen electrode to copper electrode
 B) Copper electrode to hydrogen electrode
 C) Hydrogen electrode to HCl solution
 D) CuSO_4 solution to hydrogen electrode

Q.70

Study the following redox reaction:



- A) Manganese is oxidized from +7 to +2
 B) Chlorine ions are reduced from -1 to zero
 C) Chlorine is reduced from zero to -1
 D) Manganese is reduced from +7 to +2

Q.71

Human blood maintains its pH between:

- A) 6.50 - 7.00
 B) 7.20 - 7.25
 C) 7.50 - 7.55
 D) 7.35 - 7.40

Q.72

Value of K_{sp} for PbSO_4 system at 25°C is equal to:

- A) $1.6 \times 10^{-5} \text{ mol}^2\text{dm}^{-6}$
 B) $1.6 \times 10^{-6} \text{ mol}^2\text{dm}^{-6}$
 C) $1.6 \times 10^{-8} \text{ mol}^2\text{dm}^{-6}$
 D) $1.6 \times 10^{-7} \text{ mol}^2\text{dm}^{-6}$

Q.73 $2A + B \longrightarrow \text{Product}$

If the reactant 'B' is in excess, the order of reaction with respect to 'A' in given rate law,

Rate = $k[A]^2[B]$ is:

- A) 2nd order reaction
 B) 1st order reaction
 C) Pseudo 1st order reaction
 D) 3rd order reaction

Q.74 The rate constant 'k' is 0.693 min⁻¹. The half-life for the 1st order reaction will be:

- A) 1 min
 B) 2 min
 C) 0.693 min
 D) 4 min

Q.75 Melting points of group II-A elements are higher than those of group I-A because:

- A) Atoms of II-A elements have smaller size
 B) II-A elements are more reactive
 C) Atoms of II-A elements provide two binding electrons
 D) I-A elements have smaller atomic radius

Q.76 The ionic radius of fluoride ion is:

- A) 72 pm
 B) 95 pm
 C) 136 pm
 D) 157 pm

Q.77 $2\text{NaOH}_{(aq)} + \text{Cl}_{2(g)} \longrightarrow \text{NaCl} + \text{NaClO} + \text{H}_2\text{O}$ proceed at:

- A) 500 °C
 B) 200 °C
 C) -10 °C
 D) 15 °C

Q.78 Which halogen molecule 'X₂' has lowest dissociation energy?

- A) Cl₂
 B) Br₂
 C) I₂
 D) F₂

Q.79 The anomalous electronic configuration shown by chromium and copper among 3-d series of elements is due to:

- A) Colour of ions of these metals
 B) Variable oxidation states of metals
 C) Stability associated with this configuration
 D) Complex formation tendency of metals

Q.80 Which element of 3d series of periodic table shows the electronic configuration of 3d⁶, 4s²?

- A) Copper
 B) Cobalt
 C) Zinc
 D) Nickel

Q.81 The %age of nitrogen in ammonium nitrate is:

- A) 46%
 B) 82%
 C) 33%
 D) 13%

Q.82 Which one of the following is anhydride of sulphuric acid?

- A) Sulphur (II) oxide
 B) Sulphur (VI) oxide
 C) Iron pyrite
 D) Sulphur (VI) oxide

Q.83 During contact process of H₂SO₄ synthesis, the following reaction occurs:

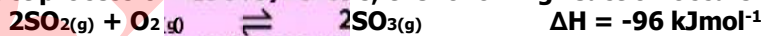

Which step is used to increase the yield of SO₃?

- A) Temperature is raised to very high degree
 B) SO₃ formed is removed very quickly
 C) Both temperature and pressure are kept very low
 D) An excess of air is used to drive the equilibrium to the right side

Q.84 Synthesis of ammonia by Haber's process is a reversible reaction. What should be done to increase the yield of ammonia in the following reaction?

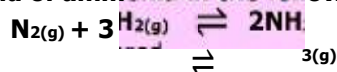

$$\Delta H = -92 \text{ kJmol}^{-1}$$

- A) Pressure should be decreased
 B) Ammonia should remain in reaction mixture
 C) Pressure should be increased
 D) Concentration of nitrogen should be decreased

Q.85 Which one of the following reactions shows combustion of a saturated hydrocarbon?

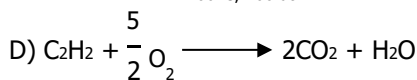
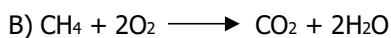
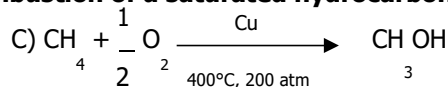
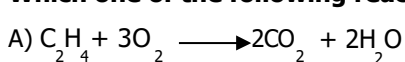

Q.86 Skeletal formula of an organic compound is given below:

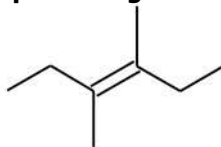

It is a hydrocarbon. IUPAC name of the compound is:

- A) 3, 3-dimethyl-3-hexene
 B) 3, 4-dimethyl-3-hexene
 C) 3-hexene
 D) 2,3-dimethyl-1-hexene

Q.87 Which one of the following pairs can be cis-trans isomer to each other?

- A) $\text{CHCl}=\text{CCl}_2$ and $\text{CH}_2=\text{CH}_2$
 B) $\text{CHCl}=\text{CH}_2$ and $\text{CH}_2=\text{CHCl}$
 C) $\text{CH}_3-\text{CH}=\text{CH}-\text{CH}_3$ and $\text{H}_3\text{C}-\text{CH}=\text{CH}-\text{CH}_3$
 D) CH_3-CH_3 and $\text{CH}_2=\text{CH}_2$

Q.88 Consider the reaction given below:

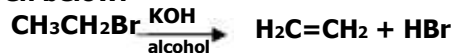

Mechanism followed by the reaction is:

- A) E2
 B) E1
 C) $\text{S}_{\text{N}}1$
 D) $\text{S}_{\text{N}}2$

Q.89 The average bond energy of C-Br is:

- A) 228 kJmol^{-1}
 B) 200 kJmol^{-1}
 C) 250 kJmol^{-1}
 D) 290 kJmol^{-1}

Q.90 Which one of the following is NOT a nucleophile:

- A) NH_2^-
 B) H_2O
 C) BF_3
 D) CH_3^-

Q.91 Which one of the following is an appropriate ion of the following iodometric test?

- A) Formation of H_2O
 B) Release of H_2 gas
 C) Release of iodine
 D) Formation of precipitate

Q.92

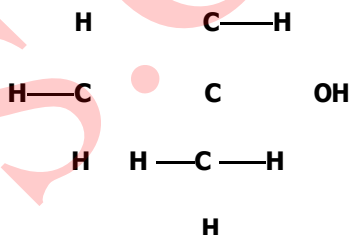

Which one of the following is the proper classification of above formula:

- A) Primary
 B) Secondary
 C) Tertiary
 D) Polyhydride

Q.93 Which one of the following is an appropriate structure of product of bromination?

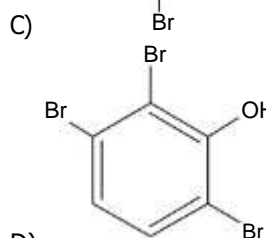
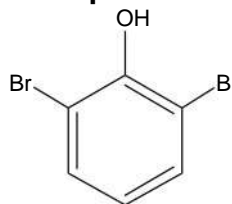
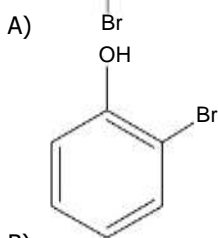
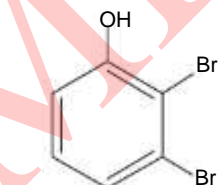

Q.94

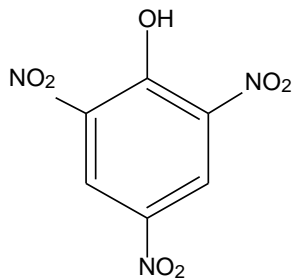

Which one of the following is an appropriate name of above compound?

- A) 1,3,6-Trinitrophenol
 B) m-Nitrophenol
 C) Tartaric acid
 D) Picric acid

Q.95

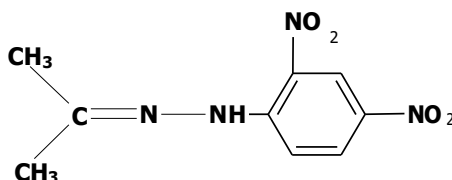

It is the general formula of:

- A) 2, 4-Dinitrophenyl hydrazine
 B) 1, 3-Dinitrophenyl hydrazine
 C) Phenyl hydrazone
 D) 2, 4-Dinitrophenyl hydrazine

Q.96

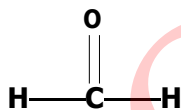

Which one of the following is the IUPAC name of above given structure:

- A) Propionaldehyde
 B) Methanone
 C) Acetaldehyde
 D) Methanal

Q.97

Which one of the following test is given by both aldehyde and ketone?

- A) Silver mirror test
 B) Fehling's solution test
 C) 2, 4 DNPH test
 D) Benedict's solution test

Q.98



Which one of the following will act as a catalyst in above reaction?

- A) HNO_3
 B) H_2SO_4
 C) Acidified potassium dichromate
 D) SOCl_2

Q.99



Which one of the following options shows the products of above reaction?

- A) $\text{POCl}_2 + \text{CH}_3\text{COCl}_2 + \text{HCl}$
 B) $\text{POCl}_3 + \text{CH}_3\text{COCl}_2 + \text{H}_2$
 C) $\text{CH}_3\text{COCl} + \text{POCl}_2 + \text{HCl}$
 D) $\text{POCl}_3 + \text{CH}_3\text{COCl} + \text{HCl}$

Q.100

Which one of the following reaction of carboxylic acid is reversible?

- A) Esterification
 B) Salt formation
 C) Reaction with PCl_5
 D) Reaction with SOCl_2

Q.101

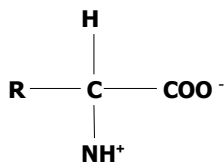

Select the best option indicating the name of the above structure:

- A) Cation
 B) Neutral amino acid
 C) Internal salt
 D) Anion

Q.102

When acid is added to an amino acid, which one of the following will act as a base?

- A) NH_3^+
 B) COO^-
 C) H^+
 D) R group

ENGLISH

- Q.103** His theories have been _____ by recent research.
 A) Pronounced C) Dammed
 B) Rearmed D) Debunked
- Q.104** International rules _____ the number of foreign entrants.
 A) Hoodwink C) Fabricate
 B) Stipulate D) Traverse
- Q.105** The assassination of the president _____ the country into war.
 A) Articulated C) Hobbled
 B) Boomed D) Precipitated
- Q.106** She might be forgiven for _____ beneath the pressure.
 A) Undertaking C) Buckling
 B) Extricating D) Resounding

⇒ **SPOT THE ERROR: In the following sentences, some segments of each sentence are underlined. Your task is to identify that underlined segment of the sentence, which contains the mistake that needs to be corrected. Fill the Circle corresponding to that letter under the segment in the MCQ Response Form.**

- Q.107** It showed that he was a man capable of looking beneath the surface of things, a man not dependent in paper manifestations.
 A) B) C) D)
- Q.108** When he was a child, every time he were naughty, his foster-mother used to threaten to send him to Timbuktu.
 A) B) C) D)
- Q.109** I was faced with alternatively of either evicting the books or else leaving them in sole, undisturbed tenancy and taking rooms elsewhere for myself.
 A) B) C) D)
- Q.110** I remember going to the British museum one day to read for the treatment for some slight ailment of which I had a touch-hay fever, I fancy it was.
 A) B) C) D)
- Q.111** The number of people in the world are rapidly increasing rather like a gigantic snowball which not only gets bigger as it rolls but goes faster as well.
 A) B) C) D)
- Q.112** It has been calculated that unless the growth is checked, there will only be enough room on the earth for people to stand by.
 A) B) C) D)

⇒ **In each of the following question, four alternative sentences are given. Choose the CORRECT one and fill the Circle corresponding to that letter in the MCQ Response Form.**

- Q.113**
 A) Inside a carton was a push-button unit fastened with a small wooden box.
 B) Inside a carton was a push-button unit fastened by a small wooden box.
 C) Inside a carton was a push-button unit fastened to a small wooden box.
 D) Inside a carton was a push-button unit fastened along a small wooden box.

Q.114

- A) They both looked to one another, startled by all they had just finished saying.
- B) They both looked to each another, startled by all they had just finish saying.
- C) They both looked to each another, startle by all they had just finish saying.
- D) They both looked to each another, startled by all they had just finished saying.

Q.115

- A) The lovely sentiments we go through repeating!
- B) The lovely sentiments we go about repeating!
- C) The lovely sentiments we go in repeating!
- D) The lovely sentiments we go for repeating!

Q.116

- A) With the bright light, still in her eyes, she moved quick out of the door.
- B) With the bright light, still in her eyes, she moved quick out to the door.
- C) With the bright light, still in her eyes, she moved quickly out to the door.
- D) With the bright light, still in her eyes, she moved quickly out of the door.

Q.117

- A) In a short while quiet a large crowd had been collected.
- B) In a short while quite a large crowd had collected.
- C) In a short while quite large crowd had collected.
- D) In a short while quite the large crowd had been collecting.

Q.118

- A) She watched all the important matches in the Brookfield ground.
- B) She watched all the important matches on the Brookfield ground.
- C) She watched all the important matches from the Brookfield ground.
- D) She watched all the important matches within the Brookfield ground.

Q.119

- A) Something had happened, something whose ultimate significance had yet to be reckon.
- B) Something had happened, something whose ultimate significance had yet was reckon.
- C) Something had happened, something whose ultimate significance had yet to be reckoned.
- D) Something had happened, something whose ultimate significance had yet reckoned.

Q.120

- A) His faculties were all unimpairment, and he had no personal worries of any kind.
- B) His faculties were all unimparing, and he had no personal worries of any kind.
- C) His faculties were all unimpaired, and he had no personal worry of any kind.
- D) His faculties were all unimpaired, and he had no personal worries of any kind.

Q.121

- A) It was hard to him to speak out loud, but he managed to murmur something.
- B) It was hard on him to speak out loud, but he managed to murmur something.
- C) It was hard for him to speak out loud, but he managed to murmur something.
- D) It was hard upon him to speak out loud, but he managed to murmur something.

Q.122

- A) There was a little money saved up beside.
- B) There was little money saved in besides.
- C) There was little money saved up beside.
- D) There was a little money saved up besides.



In each of the following question, four alternative meanings of a word are given. You have to select the NEAREST CORRECT MEANING of the given word and fill the appropriate Circle on the MCQ Response Form.

Q.123 **STALWART**

- A) Loyal
- B) Lazy
- C) Lacking strength
- D) High

Q.124 **CHIVALRY**

- A) Coward
- B) Non-cooperative
- C) Imitating
- D) Gallant

- Q.125 RAKISH**
 A) Curved
 B) Traditional
 C) Formal
 D) Dashing
- Q.126 PRODIGIOUS**
 A) Huge
 B) Trivial
 C) Little
 D) Square
- Q.127 IMPROVISE**
 A) Colophon
 B) Concoct
 C) Divert
 D) Respite
- Q.128 PARADOX**
 A) Anomaly
 B) Prototype
 C) Steward
 D) Fashion
- Q.129 MANIFESTATION**
 A) Mode
 B) Token
 C) Quirk
 D) Bulwark
- Q.130 RECONNOITRE**
 A) Patrol
 B) Arcane
 C) Exhort
 D) Falter
- Q.131 SOJOURN**
 A) Visit
 B) Belch
 C) Furry
 D) Inking
- Q.132 MUSE**
 A) Immaculate
 B) Chew over
 C) Sigh over
 D) Vagary

BIOLOGY

- Q.133 Random, uncontrolled activity of some cells in the brain leading to chaotic activity in both sensory and motor nerves causes patients of to see and hear different strange things.**
 A) Epilepsy
 B) Parkinson's Disease
 C) Alzheimer's Disease
 D) Huntington's Disease
- Q.134 Part of hind brain responsible for the balance and equilibrium of body is called:**
 A) Medulla
 B) Cerebellum
 C) Pons
 D) Thalamus
- Q.135 Events of menstrual cycle are regulated by the:**
 A) Ethylene
 B) Gonadotrophins
 C) Auxins
 D) Gibberellins
- Q.136 Decrease of FSH and increase of estrogen cause pituitary gland to secrete:**
 A) Somatotropin
 B) Luteinizing Hormone
 C) Testosterone
 D) Spermatogonium
- Q.137 Transmission of Neisseria gonorrhoea is best described by which one of the following?**
 A) Oro-fecal Route
 B) Unsafe Sex
 C) Vector Borne
 D) Droplet Infection
- Q.138 Syphilis is caused by:**
 A) Spirochete
 B) Nostoc
 C) Water blooms
 D) Cyanobacteria
- Q.139 AIDS is caused by:**
 A) Bacteria
 B) Virus
 C) Fungi
 D) Alga

Q.140 Brain is protected and enclosed in:

- A) Lumbar vertebrae
- B) Coccyx
- C) Vertebral column
- D) Cranium

Q.141 Longest bone in the human skeleton is:

- A) Ulna
- B) Fibula
- C) Tibia
- D) Femur

Q.142 Hips and shoulder joints are examples of:

- A) Hinge Joints
- B) Ball and Socket Joints
- C) Synovial Joints
- D) Cartilaginous Joints

Q.143 In pelvic region of human body, sacrum is formed by the fusion of:

- A) 4 Vertebrae
- B) 5 Vertebrae
- C) 6 Vertebrae
- D) 3 Vertebrae

Q.144 Each muscle fibre is surrounded by a modified cell membrane called:

- A) Sarcolemma
- B) Sarcomere
- C) Myosin Filament
- D) Myofilament

Q.145 _____ hormone is antagonistic to insulin and causes increase in blood glucose level.

- A) Glucagon
- B) Nor-epinephrine
- C) Calcitonin
- D) Thyroxine

Q.146 Beta cells of islets of Langerhans produce _____ hormone.

- A) Glucagon
- B) Insulin
- C) Pancreatic Juice
- D) Parathormone

Q.147 The central portion of adrenal gland (Adrenal Medulla) produces _____ hormone.

- A) Aldosterone
- B) Epinephrine
- C) Androgen
- D) Corticosterone

Q.148 _____ hormones are called fight and flight hormones as they prepare an organism to face stressful situation.

- A) Adrenaline, Aldosterone
- B) Epinephrine, Nor-epinephrine
- C) Cortisone, Oxytocin
- D) Thyroxine, Nor-epinephrine

Q.149 B-cells release antibodies in blood plasma, tissue fluid and lymph. This kind of immune response is called:

- A) Cell Mediated Response
- B) Humoral Response
- C) Active Response
- D) Compound Response

Q.150 The type of immunity in which antibodies are passed from one individual to another is called:

- A) Passive Immunity
- B) Artificial Active Immunity
- C) Natural Active Immunity
- D) Humoral Immunity

Q.151 To combat the active infections of tetanus, rabies and snakes the _____ method of immunization is used:

- A) Active
- B) Humoral
- C) Active Artificial
- D) Passive

Q.152 In antibody molecule, two heavy and two light chains are bonded by:

- A) Disulphide Bond
- B) Monosulphide Bond
- C) Hydrogen Bond
- D) Ionic Bond

Q.153 Variable amino acid sequences in antibody molecule are found in _____

- A) Both light chains only
- B) Both heavy chains only
- C) One heavy and one light chain
- D) Both heavy and light chains

Q.154 Each _____ consists of a light gathering antenna complex and reaction center.

- A) Chlorophyll
- B) Photosystem
- C) Photon
- D) Electron

Q.155 Photosystem

- A) 680 nm
B) 780 nm

Q.156 Cyclic flow

- A) ATP and O₂
B) ATP

Q.157 Immediate

- A) Unstable
B) Unstable

Q.158 Functional

- A) —CH₃
B) —CHO

IMPORTANT

Unit Wise MDCAT Past Papers
Book is Very Important for the
Preparation. This Book
Available only online With
Free Home Delivery.

Q.159 The modified plasmid or phage DNA is called:

- A) Clone DNA
B) Recombinant DNA
C) cDNA
D) rDNA

Q.160 The rapid exchange of materials through carrier proteins across the plasma membrane is called:

- A) Passive Diffusion
B) Active Transport
C) Endocytosis
D) Facilitated Diffusion

Q.161 The inner membrane of mitochondria form extensive infoldings called:

- A) Cristae
B) Cisternae
C) Lamella
D) Bifidae

Q.162 Which one of the following organelle is found in both prokaryotic and eukaryotic cells?

- A) Centriole
B) Endoplasmic Reticulum
C) Nucleus
D) Ribosome

Q.163 The compounds which on hydrolysis yield polyhydroxy aldehyde or ketone subunits are:

- A) Lipids
B) Proteins
C) Polynucleotides
D) Carbohydrates

Q.164 Which one of the following is the formula structure of D (α) glucose?

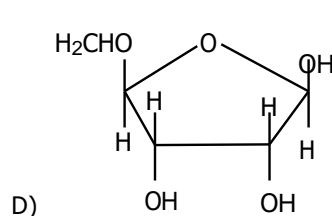
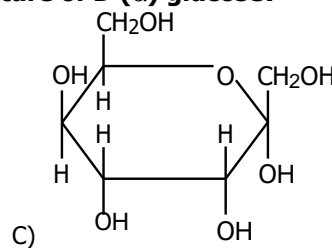
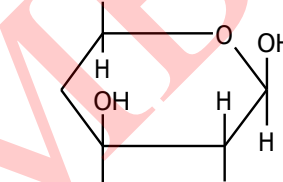
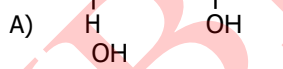
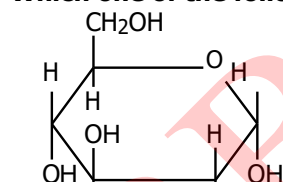

Q.165 Secondary structure of protein is found in:

- A) Trypsin
B) Keratin
C) Insulin
D) Glucagon

Q.166 Waxes are formed by combination of fatty acids with:

- A) Alcohol
B) Glycerol
C) Serine
D) Cysteine

Q.167 **Phosphodiester bond is:**

- A) P—O—C—P—O—C
 B) C—O—P
 C) C—O—P—O—C
 D) C—C—O—P

Q.168 **An enzyme required Mg⁺⁺ to catalyze the substrate. The Mg⁺⁺ is best identified as:**

- A) Prosthetic group
 B) Activator
 C) Co-enzyme
 D) Inhibitor

Q.169

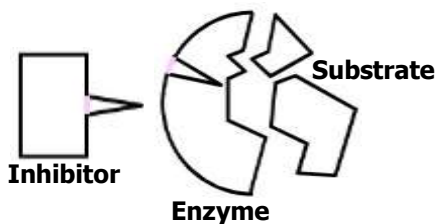

This figure represents _____ inhibitor.

- A) Non-competitive
 B) Competitive
 C) Irreversible
 D) Isosteric

Q.170 **According to _____ model the active site of enzyme is modified as the substrate interacts with enzyme.**

- A) Induced fit
 B) Lock and Key
 C) Emil Fischer
 D) Fluid Mosaic

Q.171 **Which one of the following graphs shows how the rate of reaction of pepsin is affected by pH?**

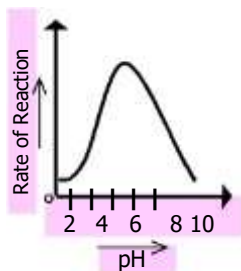

A)

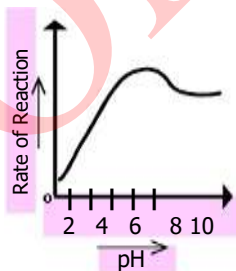

B)

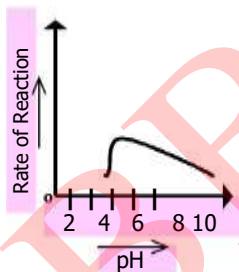

C)

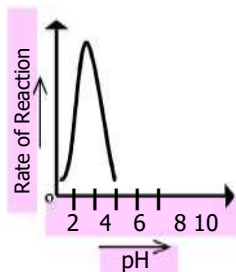

D)

Q.172 **All viruses can reproduce within living organisms only, so they are known as:**

- A) Ectoparasites
 B) Endoparasites
 C) Obligative Intracellular Parasites
 D) Facultative Intracellular Parasites

Q.173 **Many bacteria are motile due to presence of:**

- A) Flagella
 B) Pili
 C) Cilia
 D) Microtubules

Q.174 _____ is an invagination of cell membrane which helps in cell division.

- A) Fimbriae
 B) Nucleoid
 C) Mesosome
 D) Endospore

Q.175 _____ is the yeast that grows in the mucous membrane of mouth or vagina.

- A) Candida albicans
 B) Saccharomyces cerevisiae
 C) Aspergillus fumigatus
 D) Aspergillus flavus

READ ME

MDCAT UNIT WISE PAST PAPERS Book By Mbbs.com.pk is recommended by the topper. This book is only available on website mbbs.com.pk with Free Home Delivery.
Do not Waste Your Time. Get MDCAT Unit Wise Past Paper Book.

- Q.176** **Taenia is a**
A) Cnidaria
B) Aschelmin
- Q.177** **Body of**
A) Planaria
B) Ascaris
- Q.178** _____ **nematode.**
A) Taenia so
B) Schistosoma
- Q.179** **In radial symmetry all body parts are arranged around the central axis. Radial symmetry represents _____ mode of life.**
A) Sessile
B) Streamlined
C) Active
D) Parasitic
- Q.180** **Pseudo-coelomates have a body cavity but it is not true coelom. Which one of the following is included in the group.**
A) Planaria
B) Tapeworm
C) Earthworm
D) Ascaris
- Q.181** **Digestion of _____ starts in oral cavity due to the action of enzyme present in saliva.**
A) Starch
B) Cellulose
C) Fatty Acids
D) Polypeptides
- Q.182** **Food enters from stomach into small intestine through:**
A) Pyloric Sphincter
B) Cardiac Sphincter
C) Semilunar valve
D) Diaphragm
- Q.183** _____ **are the part of a gastric gland which produce hydrochloric acid.**
A) Parietal Cells
B) Goblet Cells
C) Chief Cells
D) Zymogen Cells
- Q.184** **Protein components of food are digested by the enzymatic secretion of:**
A) Goblet Cells
B) Parietal Cells
C) Zymogen Cells
D) Oxyntic Cells
- Q.185** **Digestive System consists of different layers, the innermost is known as:**
A) Submucosa
B) Mucosa
C) Muscularis
D) Serosa
- Q.186** **In human the closed sac which surrounds the heart is:**
A) Endocardium
B) Myocardium
C) Pericardium
D) Epicardium
- Q.187** **Chordae tendinea are fibrous cords attached with:**
A) Cardiac end of stomach valve
B) Tricuspid valve of heart
C) Pyloric sphincter of stomach
D) Eyelid
- Q.188** **Bicuspid valve controls the flow of blood from:**
A) Right atrium to right ventricle
B) Right ventricle to pulmonary artery
C) Left ventricle to aorta
D) Left atrium to left ventricle
- Q.189** **Carboxyhaemoglobin (10-20%) is formed when CO₂ combines with:**
A) Amino group of haemoglobin
B) Iron part of haemoglobin
C) Haem portion of haemoglobin
D) Plasma proteins
- Q.190** **Breathing consists of:**
A) Four phases
B) Three phases
C) One phase
D) Two phases

Q.191 Bowman's capsule continues as extensively convoluted portion known as:

- A) Peritubular capillaries
- B) Proximal convoluted tubules
- C) Efferent arterioles
- D) Afferent arterioles

Q.192 Restriction endonucleases cleave the _____ of duplex DNA.

- A) Nitrogenous base
- B) Base sugar
- C) Phosphodiester bond
- D) Hydrogen bond

Q.193 The enzyme which is responsible for the formation of bond between two double stranded DNA fragments is:

- A) Endonuclease
- B) Urease
- C) Ligase
- D) Helicase

Q.194 The organisms of third trophic level are:

- A) Primary consumer
- B) Primary producer
- C) Tertiary consumer
- D) Secondary consumer

Q.195 The ultimate source of energy in an ecosystem is:

- A) Photosynthesis
- B) Sun
- C) Plants
- D) Water

Q.196 All the food chains and food webs begin with:

- A) Detritus
- B) Herbivores
- C) Green plants
- D) Omnivores

Q.197 The change from bare rock or open area is rapid, especially in the initial stages and follows a series of recognizable and hence predictable stages. This process is called:

- A) Pioneers
- B) Xerosere
- C) Succession
- D) Secondary succession

Q.198 The decline in the thickness of ozone layer is caused by:

- A) Increasing level of nitrogen oxide
- B) Decreasing level of O₂
- C) Decreasing level of CFCs
- D) Increasing level of CFCs

Q.199 Which one of the following is considered as strong evidence of evolution?

- A) Embryology Record
- B) Molecular Record
- C) Biochemical Record
- D) Fossil Record

Q.200 Structures found in different species which are believed to have a common evolutionary origin are called:

- A) Homologous
- B) Analogous
- C) Vestigial
- D) Fossilized

Q.201 Which one of the following is X-linked trait?

- A) Male pattern baldness
- B) Diabetes mellitus
- C) Haemophilia
- D) Erythroblastosis fetalis

Q.202 A character determined by three alleles is:

- A) Human skin colour
- B) Human blood group
- C) Human eye colour
- D) Human Rh factor

Q.203 The total number of genes in a population is called:

- A) Gene pool
- B) Allele pool
- C) Genome
- D) Genomic library

Q.204 _____ is the branch of Biology used for the identification and interpretation of fossils.

- A) Evolution
- B) Paleontology
- C) Zoogeography
- D) Biodiversity

Q.205 Out of the given options, choose the one which shows the structures found only in plants

- A) Vacuole, Chloroplast, Ribosomes
- B) Chloroplast, Microtubules, Peroxisomes
- C) Chloroplast, Cell Wall, Vacuole
- D) Chloroplast, Cell Wall, Mitochondria

- Q.206 Presence of large central vacuole is the characteristic of:**
 A) Prokaryotes C) Fungi
 B) Protists D) Plants
- Q.207 The basic structure of plasma membrane is provided by:**
 A) Proteins C) Cytoskeleton
 B) Cholesterols D) Phospholipids
- Q.208 The organelle involved in detoxification of drugs and poisons in the liver cells is:**
 A) Smooth Endoplasmic Reticulum C) Golgi Apparatus
 B) Rough Endoplasmic Reticulum D) Lysosomes
- Q.209 Down's syndrome is characterized by _____ at chromosome 21.**
 A) Trisomy C) Polysomy
 B) Monosomy D) Disomy
- Q.210 Which of the following is an example of autosomal non-disjunction?**
 A) Turner's Syndrome C) Metastasis
 B) Jacob's Syndrome D) Down's syndrome
- Q.211 Infertility, short height, webbed neck and low hairline at lack are symptoms of _____ syndrome.**
 A) Turner's C) Edward's
 B) Down's D) Patau's
- Q.212 The concentration of sodium ions in body fluids is controlled by the hormone:**
 A) Renin C) Angiotensin
 B) Aldosterone D) CPK
- Q.213 A hormone released from posterior pituitary lobe acts to be actively transport water from filtrate is collecting tubules back to kidney is shown as:**
 A) Renin C) Angiotensin
 B) Antidiuretic hormone D) Growth Factor
- Q.214 The removal metabolic waste from the blood is called:**
 A) Thermoregulation C) Kidney Failure
 B) Osmoregulation D) Excretion
- Q.215 Highly toxic nitrogenous excretory product is:**
 A) CO₂ C) Urea
 B) Uric Acid D) Ammonia
- Q.216 Humans have homeostatic thermostat present in a specified portion of the brain that is:**
 A) Lateral ventricle C) Spinal Cord
 B) Thalamus D) Hypothalamus
- Q.217 The disease in which death of small number of cells in the basal ganglia leads to inability to select and initiate patterns of movement is known as:**
 A) Fever C) Epilepsy
 B) Alzheimer's Disease D) Parkinson's Disease
- Q.218 A neurological disorder characterized by the decline in brain function is _____. Its symptoms are similar to those diseases that cause dementia.**
 A) Parkinson's Disease C) Alzheimer's Disease
 B) Epilepsy D) Diabetes
- Q.219 A discharge by brain which causes chaotic activity in motor and sensory areas is:**
 A) Meningitis C) Epilepsy
 B) Alzheimer's Disease D) Parkinson's Disease
- Q.220 XXX
 XXXXXXXXXXXXXXX.**
 A) XXXXXX C) XXXXXX
 B) XXXXXX D) XXXXXX (X)



UHS MDCAT Past papers Unit-wise Solved (2008-2019) current edition is available now at www.mbbs.com.pk/reparation A complete Solved Past papers Hard Copy booklet for 100% UHS MDCAT Entry Test preparation.

For Order Call/WhatsApp 03047418334

How To Place Order For Helping Material Book For NUMS Entry Test:

- **Follow steps:**

- Visit www.mbbs.com.pk
- On Mobile screen follow these two steps

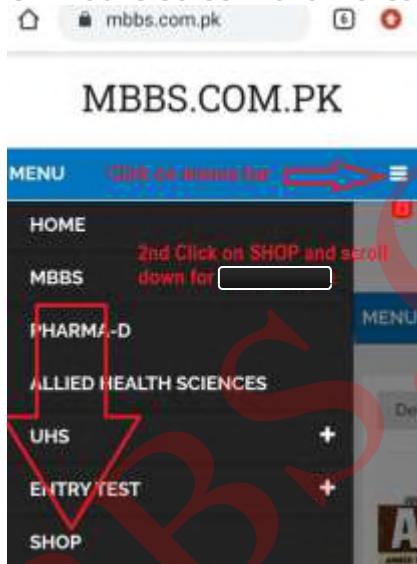

- ON Desktop Follow these steps



UHS MDCAT PAST PAPERS UNIT-WISE SOLVED

<https://mbbs.com.pk/product/mdcat-past-papers/>

www.mbbs.com.pk