



---

# **UNIVERSITY OF HEALTH SCIENCES (UHS), LAHORE**

---

## **MEDICAL COLLEGE APTITUDE TEST (MCAT) UNIT WISE PAST PAPERS (2008-2016)**



Catalogued by **ALI RAZA**



2011-2016

# MEDICAL COLLEGE APTITUDE TEST - PHYSICS

UHS, LAHORE

PAST PAPERS UNIT WISE MCQS

Ali Raza

ARK



# Table of Specification



NO.	UNIT NAME	MCQs
1.	PHYSICAL QUANTITIES AND UNITS	2
2.	FORCES	2
3.	FLUID DYNAMICS	3
4.	LIGHT	4
5.	WAVES	4
6.	DEFORMATION OF SOLIDS	2
7.	IDEAL GASES	2
8.	HEAT AND THERMODYNAMICS	3
9.	ELECTRONICS	2
10.	CURRENT ELECTRICITY	3
11.	MAGNETISM AND ELECTROMAGNETISM	3
12.	MODERN PHYSICS	7
13.	NUCLEAR PHYSICS	7
TOTAL:		44



## Contents

NO.	UNIT NAME	PAGE NO
1.	PHYSICAL QUANTITIES AND UNITS	4
2.	FORCES	6
3.	FLUID DYNAMICS	9
4.	LIGHT	12
5.	WAVES	15
6.	DEFORMATION OF SOLIDS	19
7.	IDEAL GASES	21
8.	HEAT AND THERMODYNAMICS	23
9.	ELECTRONICS	26
10.	CURRENT ELECTRICITY	29
11.	MAGNETISM AND ELECTROMAGNETISM	33
12.	MODERN PHYSICS	37
13.	NUCLEAR PHYSICS	43

## 1

## PHYSICAL QUANTITIES AND UNITS

## 2011

- Q.1** When the dimensions of both sides of an equation are equal, then the equation is said to be
- A) Simultaneous  
B) Homologous  
C) Instantaneous  
D) Quadratic
- Q.2** Radian is a unit of angular displacement which can also be measured in degrees. How many radians are equal to one degree?
- A)  $\frac{\pi}{180}$   
B)  $\frac{180}{\pi}$   
C)  $\frac{2\pi}{180}$   
D)  $\frac{\pi}{57.3}$

## 2012

- Q.3** Electric charge on an object is measured as 5 micro coulombs. How the value of this charge can be expressed in terms of base units:
- A)  $5 \times 100$  ampere second  
B)  $5 \times 10^{-6}$  ampere second  
C)  $5 \times 10^{+6}$  coulomb second  
D)  $5 \times 100$  coulomb second
- Q.4** If 'm' is the mass, 'c' is the velocity of light and  $x = mc^2$ , then dimensions of 'x' will be:
- A)  $[LT^{-1}]$   
B)  $[ML^2T^{-2}]$   
C)  $[MLT^{-1}]$   
D)  $[MLT^{-2}]$

## 2013

- Q.5** The wavelength 'λ' of a wave depends on the speed 'v' of the wave and its frequency 'f'. Decide which of the following is correct?
- A)  $f = v \lambda$   
B)  $f = \frac{\lambda}{v}$   
C)  $f = \frac{v}{\lambda}$   
D)  $f = v \lambda^{-2}$
- Q.6** Name the quantity which can be measured by using base unit 'kgm<sup>2</sup>s<sup>-3</sup>'
- A) Weight  
B) Pressure  
C) Power  
D) Work

## 2014

- Q.7** The formula for electric field strength is 'E = F/Q', where E is electric field strength and F is force and Q is charge. Which one of the following options gives the correct base units for electric field strength?
- A) kgms<sup>-3</sup>A<sup>-1</sup>  
B) kgs<sup>-2</sup>A<sup>-3</sup>  
C) kg<sup>2</sup>m<sup>-2</sup>s<sup>-3</sup>A  
D) ms<sup>-1</sup>A<sup>-3</sup>

**Q.8 Which set of the prefixes gives values in increasing order?**

- A) Pico, Mega, Kilo, Tera  
 B) Pico, Micro, Mega, Giga  
 C) Tera, Pico, Micro, Kilo  
 D) Giga, Kilo, Milli, Nano

## 2015

**Q.9 The unit of temperature in base unit is:**

- A) Celsius  
 B) Degree  
 C) Kelvin  
 D) Fahrenheit

**Q.10 The dimensions of pressure is:**

- A)  $[M^{-1}L^2T^{-2}]$   
 B)  $[ML^{-1}T]$   
 C)  $[M^{-1}L^{-2}T^{-2}]$   
 D)  $[ML^{-1}T^{-2}]$

## 2016

**Q.11 The time period 'T' of a simple pendulum depends on its length 'l' and acceleration due to gravity 'g' using unit dimension. The correct equation for time period is:**

- A)  $T = k \sqrt{\frac{g}{l}}$  where 'k' is constant  
 B)  $T = \frac{1}{k} \sqrt{\frac{g}{l}}$  where 'k' is constant  
 C)  $T = k \sqrt{\frac{l}{g}}$  where 'k' is constant  
 D)  $T = \frac{1}{k} \sqrt{\frac{l}{g}}$  where 'k' is constant

**Q.12 The unit for electric charge is Coulomb and one Coulomb in terms of base unit is equivalent to:**

- A) Am  
 B)  $Js^{-1}$   
 C) As  
 D) C

<b>ANSWERS</b>	<b>Q.1</b>	B	<b>Q.7</b>	A
	<b>Q.2</b>	B	<b>Q.8</b>	B
	<b>Q.3</b>	B	<b>Q.9</b>	C
	<b>Q.4</b>	B	<b>Q.10</b>	D
	<b>Q.5</b>	C	<b>Q.11</b>	<b>X</b>
	<b>Q.6</b>	D	<b>Q.12</b>	C

## 2

## FORCES

## 2011

**Q.1 An elevator is moving upwards with constant velocity of 'v'. What is a weight of a person of a mass 'm' inside the elevator during upward motion?**

- A)  $mg + mv$   
 B)  $mg$   
 C)  $mg - mv$   
 D) zero

**Q.2 A simple pendulum length 'L' with bob of mass 'm' is slightly displaced from its mean position so that its string makes an angle 'θ' with vertical line as shown in the figure. Then bob of pendulum released. What will be the expression of torque with which the bob starts to move towards the mean position?**

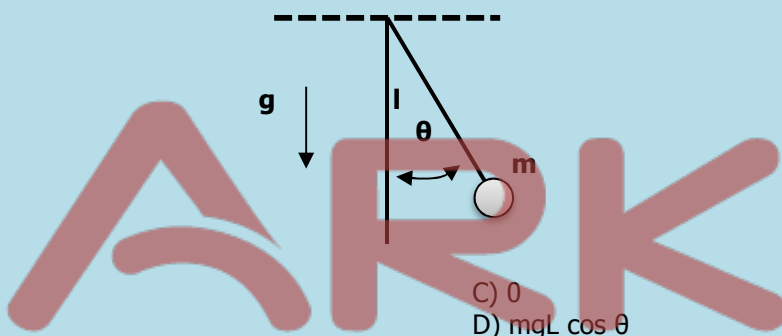

- A)  $mgL$   
 B)  $mgL \sin \theta$   
 C) 0  
 D)  $mgL \cos \theta$

## 2012

**Q.3 A force 'F' is acting at point 'P' of a uniform rod capable to rotate about 'O'. What is the torque about 'O'?**

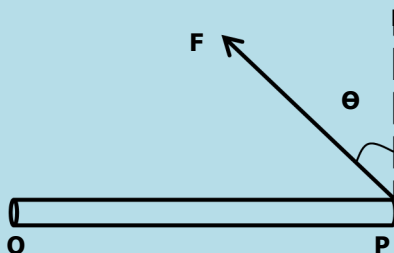

- A)  $(OP)(F \tan \theta)$   
 B)  $(OP)(F)$   
 C)  $(OP)(F \sin \theta)$   
 D)  $(OP)(F \cos \theta)$

**Q.4 An object of mass 'm' is suspended in an elevator moving downward with acceleration equal to acceleration due to gravity. What is the apparent weight of object?**

- A) Zero  
 B)  $2mg$   
 C)  $mg$   
 D)  $\frac{mg}{2}$

## 2013

- Q.5 Ratio of moment of inertia of two objects 'A' and 'B' is 2:3. Which one of the following is the ratio of torques of 'A' and 'B' respectively, if both are being rotated with constant angular acceleration?  
 A) 3:4  
 B) 2:3  
 C) 3:2  
 D) 4:3
- Q.6 Due to some mechanical fault, a lift falls freely from the top of a multistory building. Which of the followings is the apparent weight of a man inside the lift, if mass of man is 80 kg while value of 'g' is  $10 \text{ ms}^{-2}$ ?  
 A) 900 N  
 B) Zero  
 C) 800 N  
 D) 700 N

## 2014

- Q.7 Two forces, 5 N and 10 N are acting at 'O' and 'P' respectively on a uniform meter rod suspended at the position of centre of gravity 50 cm mark as shown in the figure.

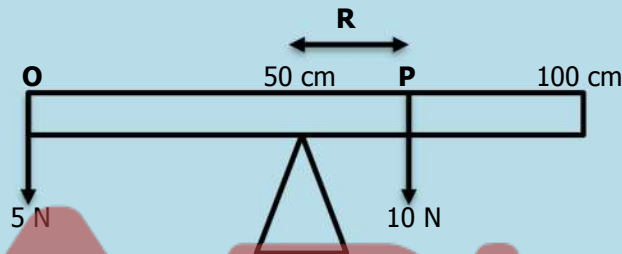

What is the position of 'P' on meter rod?

- A) 80 cm  
 B) 75 cm  
 C) 70 cm  
 D) 65 cm
- Q.8 A 100 kg man is standing in an elevator, which accidentally falls freely. What will be the weight of the person in the freely falling elevator (take  $g=10 \text{ m/s}^2$ )  
 A) 1000 N  
 B) 10 N  
 C) 500 N  
 D) Zero

## 2015

- Q.9 A bar of length 'L' pivoted at 'O' is acted by a force 'F' at an angle ' $\theta$ ' with vertical line as shown in figure;

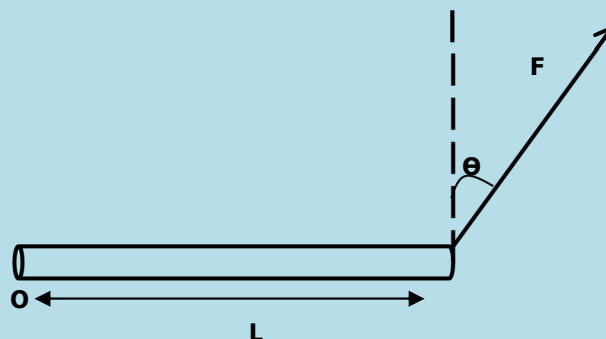

What is the moment of force?

- A)  $L \sin\theta$   
 B)  $L \cos\theta$   
 C)  $LF \cos\theta$   
 D)  $LF \sin\theta$



- Q. 10** A body is having weight 20 N, when the elevator is descended with  $a = 0.1 \text{ ms}^{-2}$ , then the value of tension 'T' is:
- A) 196 N  
C) 19.8 N  
C) 1.98 N  
D) 2 N

**2016**

- Q.11** A man in elevator ascending with an acceleration will conclude that his weight is:
- A) Increased  
B) Decreased  
C) Reduced to zero  
D) Remain Constant
- Q.12** If we double the moment arm the value of torque becomes:
- A) Half  
B) Three-times  
C) Two-times  
D) Four-times

<b>ANSWERS</b>	<b>Q.1</b>	B	<b>Q.7</b>	B
	<b>Q.2</b>	B	<b>Q.8</b>	D
	<b>Q.3</b>	D	<b>Q.9</b>	C
	<b>Q.4</b>	A	<b>Q.10</b>	C
	<b>Q.5</b>	B	<b>Q.11</b>	A
	<b>Q.6</b>	B	<b>Q.12</b>	C

## 3

## FLUID DYNAMICS

## 2011

- Q.1** An object having spherical shape of radius ' $r$ ' experiences a retarding force  $F$  from a fluid of coefficient of viscosity ' $\eta$ ' when moving through the fluid with speed ' $v$ '. What is the ratio of retarding force to speed?
- A)  $6\pi\eta r^2$   
 B)  $6\pi\eta/r^2$   
 C)  $6\pi\eta r$   
 D)  $6\pi\eta/r$
- Q.2** When the drag force is equal to the weight of the droplet, the droplet will fall with:
- A) High Speed  
 B) Low Speed  
 C) Certain acceleration  
 D) Constant Speed
- Q.3** The density of blood is:
- A) Less than water  
 B) Nearly equal to water  
 C) Greater than water  
 D) Three times that of water

## 2012

- Q.4** Stokes' Law for steady motion in a fluid of infinite extent is given by
- A)  $F = 6\pi\eta rv$   
 B)  $F = (4/3)\pi r^3 \rho g$   
 C)  $F = 6\pi\eta r^2 \rho$   
 D)  $F = 2gr^2\rho/9\eta$
- Q.5** If speed of efflux through a small hole in a large tank is 9.8 m/s. Find the height at the fluid above the hole
- A) 1 m  
 B) 9.8 m  
 C) 4.9 m  
 D) 19.6 m
- Q.6** Flow speed of the fluid through a non-uniform pipe increases from 1 m/sec to 3 m/sec. If change in P.E. is zero, then pressure difference between two points will be: (density of the fluid =  $1000 \text{ kg/m}^3$ )
- A)  $1000 \text{ N/m}^2$   
 B)  $9000 \text{ N/m}^2$   
 C)  $8000 \text{ N/m}^2$   
 D)  $4000 \text{ N/m}^2$

## 2013

- Q.7** Stokes' Law is given as:
- A)  $F = 6\pi\eta r^2 v$   
 B)  $F = 6\pi\eta rv$   
 C)  $F = 6\pi\eta r v^{-1}$   
 D)  $F = 6\pi^2 \eta r^3 v$
- Q.8** The product of cross-sectional area of the pipe and the fluid speed at any point along the pipe:
- A) Remains constant  
 B) Is zero  
 C) Exponentially increases  
 D) Exponentially decreases
- Q.9** A small leak is developed in a large water storage tank. If the height of water above leakage is 10 m, then find the speed of efflux through the leak:
- A) 14 m/sec  
 B) 10 m/sec  
 C) 9.8 m/sec  
 D) 20 m/sec

## 2014

**Q.10** Which of the following is the best graphical representation between drag force 'F' on a spherical object of radius 'r' and its speed 'v' through a fluid of viscosity 'η'?

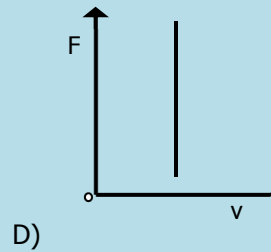
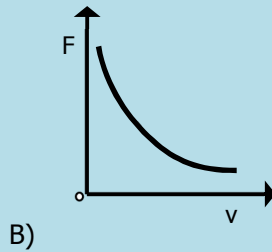
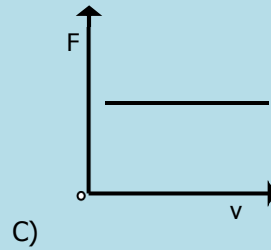
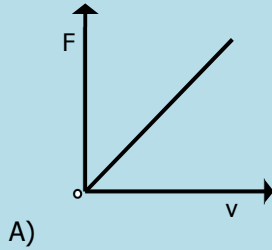

**Q.11** What is the speed of an incompressible non-viscous liquid flowing out from 'B' contained in a container as shown in the figure? Where  $AB = 5 \text{ m}$  and  $g = 10 \text{ m/s}^2$ .

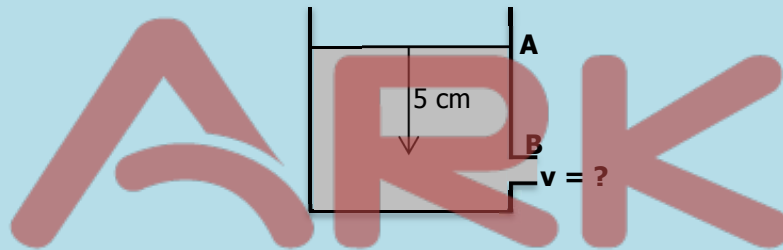

- A) 5 m/s  
B) 10 m/s

- C) 2 m/s  
D) 50 m/s

**Q.12** For the horizontal pipe, the fluid inside it is flowing horizontally then Bernoulli's equation can be written as

- A)  $P + \rho v^2 = \text{constant}$   
B)  $2P + \rho v^2 = \text{constant}$

- C)  $P + 2\rho v^2 = \text{constant}$   
D)  $2P + 2\rho v^2 = \text{constant}$

## 2015

**Q.13** In fluid flow, for the equation of continuity  $A_1 v_1 = A_2 v_2$ . If velocity of the fluid at one end is doubled, then what will be the cross-sectional area at this end?

- A) Double  
B) Half

- C) (Half)<sup>2</sup>  
D) (Double)<sup>2</sup>

**Q.14** Mass flow per second of the fluid is given by:

- A)  $\rho Av$

- C)  $\rho v$

- B)  $Av$

- D)  $\frac{Av}{\rho}$

**Q.15** The dimension of coefficient of viscosity is:

- A)  $[M^{-2}L^{-1}T^{-1}]$   
B)  $[ML^{-2}T^{-1}]$

- C)  $[ML^{-2}T^1]$   
D)  $[ML^{-1}T^{-1}]$

## 2016

- Q.16** When fluid is incompressible, the quantity is constant is:  
 A) Mass  
 B) Density  
 C) Pressure  
 D) Force
- Q.17** In Bernoulli's equation the term  $\frac{1}{2} \rho v^2$  is called:  
 A) K.E. per unit volume  
 B) K.E.  
 C) K.E. per unit area  
 D) K.E. per unit length
- Q.18** Potential energy per unit volume is given by:  
 A) mgh  
 B)  $\frac{mgh}{\rho}$   
 C) gh  
 D) pgh

<b>ANSWERS</b>	<b>Q.1</b>	B	<b>Q.7</b>	B	<b>Q.13</b>	B
	<b>Q.2</b>	D	<b>Q.8</b>	A	<b>Q.14</b>	A
	<b>Q.3</b>	B	<b>Q.9</b>	A	<b>Q.15</b>	D
	<b>Q.4</b>	A	<b>Q.10</b>	A	<b>Q.16</b>	B
	<b>Q.5</b>	C	<b>Q.11</b>	B	<b>Q.17</b>	A
	<b>Q.6</b>	D	<b>Q.12</b>	B	<b>Q.18</b>	D

## 4

## LIGHT

## 2011

- Q.1** A monochromatic light of wavelength ' $\lambda$ ' is used to produce the diffraction pattern through a single slit of width  $X$ . Which one of the following represents the intensity distribution across the screen?

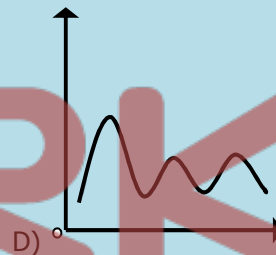
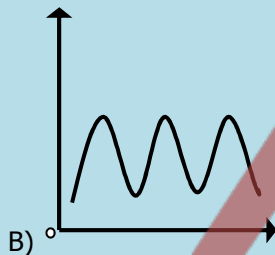
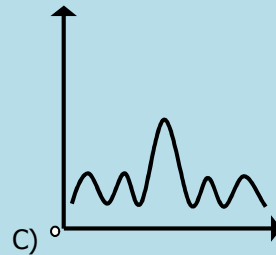
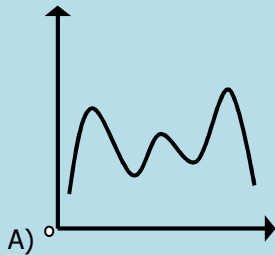

- Q.2** For interference of light waves to take place, the required condition is
- The path difference of the light waves from the two sources must be large
  - The interfering waves must be non-coherent
  - The light waves may come from different sources
  - The light waves may come from two coherent sources
- Q.3** The property of bending of light around an obstacle and spreading of light waves into geometric shadow of an obstacle is called:
- Diffraction
  - Polarization
  - Quantization of Light
  - Interference of Light
- Q.4** The normal human eye can focus a sharp image of an object on the eye if the object is located at certain distance called
- Least Point
  - Near Point
  - Far Point
  - Distinct Point

## 2012

- Q. 5** Polarization of light exhibited the nature of light as
- Longitudinal wave
  - Compressional wave
  - Transverse wave
  - Electromagnetic wave
- Q.6** The concentration of a sugar solution can be determined by
- Un-polarized light
  - Plane polarized light
  - Interference of light
  - Diffraction of light

- Q.7** The information from one place to another can be transmitted very safely and easily by:  
 A) Copper wire  
 B) Aluminium wire  
 C) Photodiode  
 D) Optical fibre
- Q.8** The image of an object placed inside the focal length of a convex lens will be largest and clearest when it is at the  
 A) Less than 25 cm  
 B) Near point  
 C) Greater than 25 cm  
 D) Infinity

## 2013

- Q.9** The minimum distance from the eye at which an object can be seen clearly without strain is called:  
 A) Focal point  
 B) Near point  
 C) Yield point  
 D) Far point
- Q.10** In the diffraction of light around an obstacle, the angle of diffraction is increased then:  
 A) The wavelength of incident light wave is increased  
 B) The wavelength of incident light wave is decreased  
 C) The amplitude of the incident light wave is increased  
 D) The amplitude of the incident light wave is decreased
- Q.11** An object 15 cm from a lens produces a real image 30 cm from the lens. What is the focal length of the lens?  
 A) +15 cm  
 B) +20 cm  
 C) +10 cm  
 D) +25 cm
- Q.12** What is the formula for critical angle in case of light through two mediums having refractive indexes  $n_1$  and  $n_2$  such that  $n_1 > n_2$ ?  
 A)  $\sin^{-1} \left( \frac{n_1}{n_2} \right)$   
 B)  $\cos^{-1} \left( \frac{n_1}{n_2} \right)$   
 C)  $\cos^{-1} \left( \frac{n_2}{n_1} \right)$   
 D)  $\sin^{-1} \left( \frac{n_2}{n_1} \right)$

## 2014

- Q.13** An oil film floating on water surface exhibits colour pattern due to the phenomenon of:  
 A) Diffraction  
 B) Polarization  
 C) Interference  
 D) Surface tension
- Q.14** The value of the least distance of distinct vision or near point is \_\_\_\_\_ for a normal human eye.  
 A) 20 cm  
 B) 25 cm  
 C) 10 cm  
 D) 15 cm
- Q.15** In a compound microscope, the magnification by objective = 20, magnification by eyepiece = 11, then the total magnification is  
 A)  $M = -220$   
 B)  $M = -0.19$   
 C)  $M = -0.05$   
 D)  $M = 220$
- Q.16** The distance between atoms is 0.30 nm. What will be the wavelength of X-rays at angle  $\theta = 30^\circ$  for 1<sup>st</sup> order diffraction?  
 A)  $\lambda = 0.60$  nm  
 B)  $\lambda = 0.30$  nm  
 C)  $\lambda = 0.20$  nm  
 D)  $\lambda = 0.90$  nm

## 2015

- Q.17** The value of least distance vision for normal eye is  
 A) 20 cm  
 B) 30 cm  
 C) 25 cm  
 D) 40 cm

**Q.18 The distance between two dark adjacent fringes is mathematically written as:**

A)  $\Delta Y = \frac{\lambda L}{d}$   
 B)  $\Delta Y = \frac{\lambda}{dL}$

C)  $\Delta Y = \frac{\lambda d}{L}$   
 D)  $\Delta Y = \frac{d}{\lambda L}$

**Q.19 In Young's Double Slit Experiment, slit separation  $x = 0.05$  cm, distance between screen and slit  $D = 200$  cm, fringes separation  $x = 0.13$  cm, then the wavelength ' $\lambda$ ' of light is:**

A)  $\lambda = 1.23 \times 10^{-2}$  m  
 B)  $\lambda = 3.25 \times 10^{-7}$  m

C)  $\lambda = 4.55 \times 10^{-5}$  m  
 D)  $\lambda = 5.1 \times 10^{-7}$  m

**Q.20 In normal adjustment of compound microscope, the eye piece is positioned so that the final image is formed at:**

A) Optical Center  
 B) Infinity

C) Principle Focus  
 D) Near Point

## 2016

**Q.21 The minimum distance from the eye at which an object appears to be distant is:**

A) 25 cm  
 B) 22 cm

C) 35 cm  
 D) 20 cm

**Q.22 Using the relation for the magnifying power  $L_o$ ,  $M = 1 + d/f$ , if  $f = 5$  cm and  $d = 25$  cm then  $M$  will be:**

A) 5  
 B) 7

C) 6  
 D) 8

**Q.23 If general equation for destructive interference's is given by the relation,**

$$\text{Optic path difference} = \left(m + \frac{1}{2}\right) \lambda$$

**where ' $m$ ' is an integer, then first dark fringe appears from ' $m$ ' will be equal to:**

A)  $\frac{2}{3}$   
 B)  $\frac{1}{2}$

C) 0  
 D) 1

**Q.24 For bright fringe formation, the path difference is:**

A)  $\left(n + \frac{1}{2}\right) \lambda$  where  $n = 0, 1, 2, \dots$

C)  $(2n + 1) \frac{\lambda}{2}$  where  $n = 0, 1, 2, \dots$

B)  $n\lambda$  where  $n = 0, 1, 2, \dots$

D)  $\left(\frac{n + 1}{2}\right) \lambda^2$  where  $n = 0, 1, 2, \dots$

<b>ANSWERS</b>	<b>Q.1</b>	C	<b>Q.7</b>	D	<b>Q.13</b>	C	<b>Q.19</b>	B
	<b>Q.2</b>	D	<b>Q.8</b>	B	<b>Q.14</b>	B	<b>Q.20</b>	D
	<b>Q.3</b>	A	<b>Q.9</b>	B	<b>Q.15</b>	D	<b>Q.21</b>	A
	<b>Q.4</b>	B	<b>Q.10</b>	A	<b>Q.16</b>	B	<b>Q.22</b>	C
	<b>Q.5</b>	C	<b>Q.11</b>	C	<b>Q.17</b>	C	<b>Q.23</b>	C
	<b>Q.6</b>	B	<b>Q.12</b>	D	<b>Q.18</b>	A	<b>Q.24</b>	B





- Q.6** When the length of a simple pendulum is doubled, find the ratio of the new frequency to the old frequency?  
 A)  $1/4$  C)  $\sqrt{2}$   
 B)  $1/2$  D)  $1/\sqrt{2}$

- Q.7** In the diagram below, the displacement of an oscillating particle is plotted against time. What does the length 'PR' on the time axis represents?

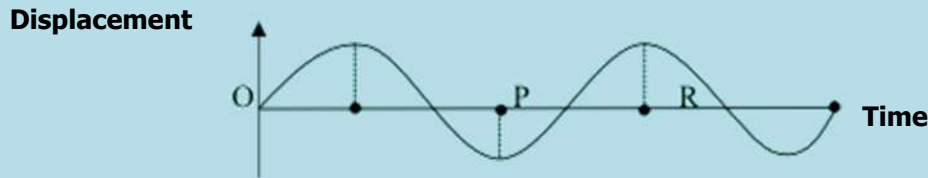

- A) Twice the frequency C) Half the frequency  
 B) Half the period D) Twice the period
- Q.8** When the source of sound moves towards the stationary observer, the value of apparent frequency ' $f_o$ ' is:  
 A)  $f_o = \left(\frac{v+u_i}{v}\right) f$  C)  $f_o = \left(\frac{v}{v+u_i}\right) f$   
 B)  $f_o = \left(\frac{v}{v-u_i}\right) f$  D)  $f_o = \left(\frac{v-u_i}{v}\right) f$

## 2013

- Q.9** For vibrating mass-spring system, the expression of kinetic energy at any displacement ' $x$ ' is given by:  
 A)  $\frac{1}{2} kx_o^2 \left(1 - \frac{x^2}{x_o^2}\right)$  C)  $\frac{1}{2} m\omega \left(1 - \frac{x^2}{x_o^2}\right)$   
 B)  $\frac{1}{2} kx_o^2$  D)  $\frac{1}{2} m\omega^2 x_o$
- Q.10** Speed of sound through a gas is measured as 340 m/s at pressure  $P_1$  and temperature  $T_1$ . What will be the speed of sound if pressure of gas is doubled but temperature is kept constant?  
 A) 342 m/s C) 170 m/s  
 B) 340 m/s D) 680 m/s
- Q.11** Variation of amplitude with respect to time for an oscillation object is shown in figure.

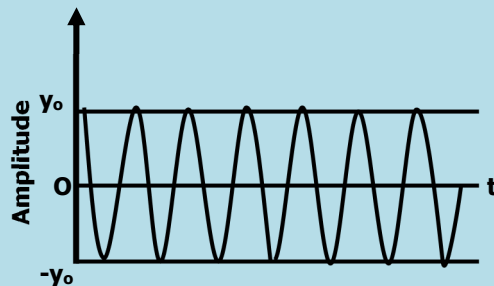

**Identify the oscillation:**

- A) Damped C) Undamped  
 B) Critical D) Heavily damped
- Q.12** In a simple harmonic motion with a radius ' $x_o$ ', the velocity of the particle at any point is:  
 A)  $v = \omega\sqrt{x_o^2 - x^2}$  C)  $v = \omega\sqrt{(x_o - x)}$   
 B)  $v = \omega(x^2 - x_o^2)$  D)  $v = \omega\sqrt{(x - x_o)}$

## 2014

- Q.13** Frequency of simple pendulum of length 9.8 m will be  
 A)  $2\pi$  Hertz  
 B)  $\pi/2$  Hertz  
 C)  $1/2\pi$  Hertz  
 D)  $\pi/4$  Hertz
- Q.14** A body performs simple harmonic motion with a period of 0.063 s. The maximum speed of  $3.0 \text{ ms}^{-1}$ . What are the values of the amplitude ' $x_0$  (m)' and angular frequency ' $\omega$  ( $\text{rads}^{-1}$ )'?  
 A)  $x_0 = 0.03, \omega = 100$   
 B)  $x_0 = 0.19, \omega = 16$   
 C)  $x_0 = 5.3, \omega = 16$   
 D)  $x_0 = 3.3, \omega = 100$
- Q.15** Food being cooked in microwave oven is an example of  
 A) Beats  
 B) Overtones  
 C) Resonance  
 D) Stationary waves
- Q.16** Potential energy of a mass spring system with respect to displacement during simple harmonic motion (SHM) is shown in the figure.

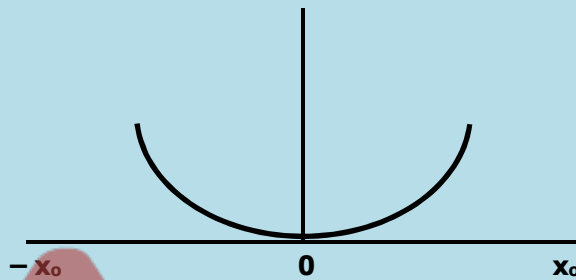

Which of the following represents the total energy of mass spring system during SHM?

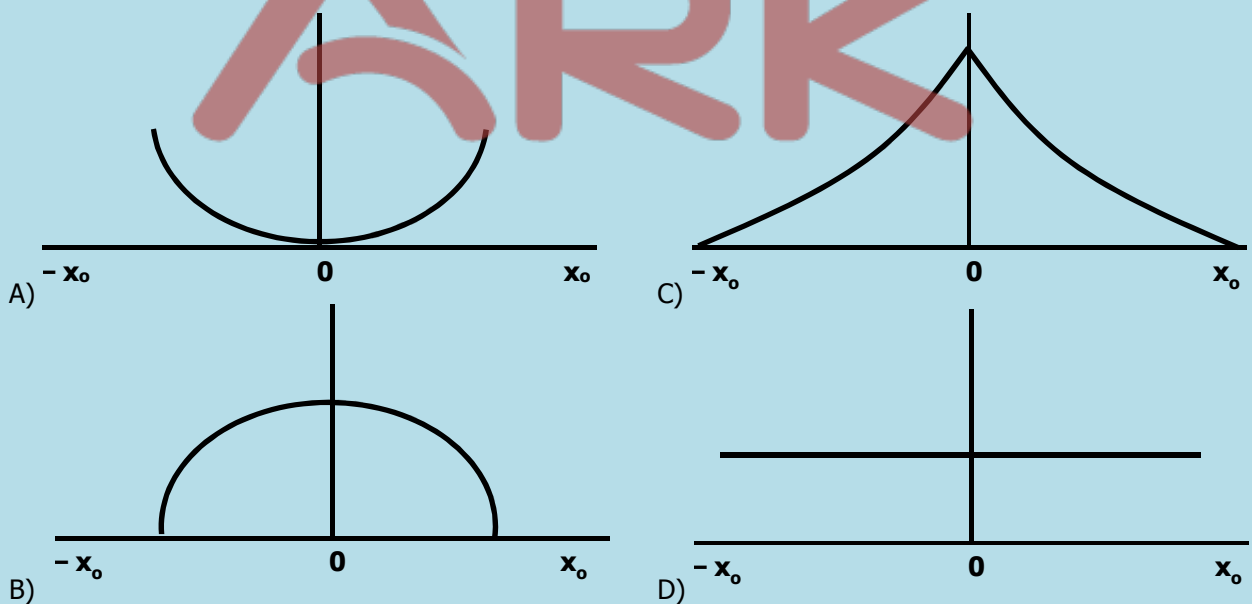

## 2015

- Q.17** Mathematical formula of maximum velocity ( $v_0$ ) for a body executing simple harmonic motion is:  
 A)  $v_0 = \omega x_0$   
 B)  $v_0 = \frac{k}{m} \sqrt{x_0^2 - x^2}$   
 C)  $v_0 = v \sqrt{1 - \frac{x^2}{x_0^2}}$   
 D)  $v_0 = m \sqrt{x_0^2 - x^2}$

- Q.18** What should be the length of simple pendulum whose period is 6.28 second at a place where  $g = 10 \text{ ms}^{-2}$ .  
 A) 0.28 m  
 B) 10.8 m  
 C) 6.28 m  
 D) 10 m
- Q.19** What should be the ratio of kinetic energy to total energy for simple harmonic oscillator?  
 A)  $1 - \frac{x^2}{x_0^2}$   
 B) 1  
 C)  $(x_0^2 - x^2)$   
 D)  $\frac{1}{2} x^2$
- Q.20** An observer moves with velocity ' $v_0$ ' toward a stationary source, then the number of waves received in one second is:  
 A)  $f' = f \left( \frac{v}{v + v_0} \right)$   
 B)  $f' = f \left( \frac{v}{v - v_0} \right)$   
 C)  $f' = f \left( \frac{v + v_0}{v} \right)$   
 D)  $f' = f \left( \frac{v - v_0}{v} \right)$

## 2016

- Q.21** Resonance occurs when the driving frequency is:  
 A) Greater than natural frequency  
 B) Unequal the natural frequency  
 C) Less than natural frequency  
 D) Equal to the natural frequency
- Q.22** The red shift measurement of Doppler effect of galaxies indicate that the universe is:  
 A) Expanding  
 B) Contracting  
 C) Stationary  
 D) Oscillating
- Q.23** Frequency audible range to human hearing lies in the range:  
 A) 2-2000 kHz  
 B) 15-50000 kHz  
 C) 20-20000 Hz  
 D) 20-20000 kHz
- Q.24** Tuning a radio is a best example of:  
 A) Natural resonance  
 B) Mechanical resonance  
 C) Free resonance  
 D) Electrical resonance

<b>ANSWERS</b>	<b>Q.1</b>	A	<b>Q.7</b>	B	<b>Q.13</b>	C	<b>Q.19</b>	A
	<b>Q.2</b>	A	<b>Q.8</b>	B	<b>Q.14</b>	A	<b>Q.20</b>	C
	<b>Q.3</b>	A	<b>Q.9</b>	D	<b>Q.15</b>	C	<b>Q.21</b>	D
	<b>Q.4</b>	D	<b>Q.10</b>	A	<b>Q.16</b>	D	<b>Q.22</b>	A
	<b>Q.5</b>	C	<b>Q.11</b>	C	<b>Q.17</b>	A	<b>Q.23</b>	C
	<b>Q.6</b>	D	<b>Q.12</b>	B	<b>Q.18</b>	D	<b>Q.24</b>	D

## 6

## DEFORMATION OF SOLIDS

## 2011

- Q.1 A wire is stretched by a force which causes an extension. The energy is stored in it only when:**  
 A) Extension of wire is proportional to force applied    C) The wire is not stretched beyond its elastic limit  
 B) The cross-section area of the wire remains constant    D) The weight of wire is negligible
- Q.2 Which statement is correct:**  
 A) Elasticity is that property of body which enables body to regain its original dimension  
 B) Elasticity is that property of a body that does not allow it to return to its original shape  
 C) Elasticity is that property of a body that allows it to retain its original shape and dimension after the stress is removed.  
 D) Elasticity is that property of a body that obeys Hooke's law.

## 2012

- Q.3 The ratio of tensile strength to tensile strain is called**  
 A) Modulus of elasticity    C) Young's Modulus  
 B) Bulk Modulus    D) Shear Modulus
- Q.4 A wire is stretched by a force 'F' which causes an extension  $\Delta l$ , the energy stored in the wire is:**  
 A)  $F\Delta l$     C)  $\frac{1}{2} F\Delta l^2$   
 B)  $2F\Delta l$     D)  $\frac{1}{2} F\Delta l$

## 2013

- Q.5 The stress-strain graph, deduced the following limits successively:**  
 A) Proportional limit, yield limit, elastic limit    C) Proportional limit, elastic limit, yield limit  
 B) Yield limit, elastic limit, proportional limit    D) Elastic limit, proportional limit, yield limit
- Q.6 A 4.0 m long wire is subjected to stretching force and its length increases by 40 cm. The percent elongation which the wire undergoes is:**  
 A) 0.10 %    C) 10 %  
 B) 40 %    D) 20 %

## 2014

- Q.7 Three graphs for three types of materials are shown in the figure.**

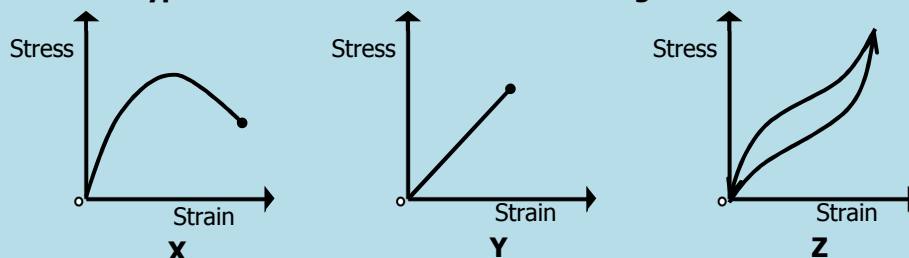

Which row describes the correct materials?

	X	Y	Z
A)	Brittle	Ductile	Polymer
B)	Brittle	Polymer	Ductile
C)	Polymer	Brittle	Ductile
D)	Ductile	Brittle	Polymer

Q.8 Which feature of the following graph represents Young's Modulus?

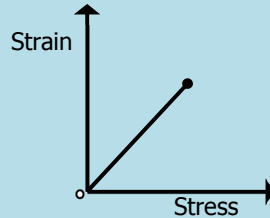

- A) Area under graph  
 B) Gradient of the graph  
 C) Reciprocal of the gradient  
 D) Product of gradient and area of the curve.

## 2015

Q.9 Strain energy in a deformed energy is stored in the form of:

- A) Elastic Energy  
 B) Potential Energy  
 C) Plastic Energy  
 D) Kinetic Energy

Q.10 A wire of area of cross section 'A' and original length 'l' is subjected to a load 'L'. A second wire of same material with an area is '2A' and length '2l' is subjected to the same load 'L'. If the extension in first wire is 'X' and second wire is 'Y', find the ratio 'X/Y'.

- A)  $\frac{1}{4}$   
 B)  $\frac{1}{2}$   
 C)  $\frac{1}{1}$   
 D)  $\frac{2}{1}$

## 2016

Q.11 The ratio of applied stress to the volumetric strain is called:

- A) Bulk Modulus  
 B) Shear Modulus  
 C) Tensile modulus  
 D) Young's Modulus

Q.12 The wire made of copper belong to which specific kind of material:

- A) Ductile material  
 B) Tough material  
 C) Brittle material  
 D) Deformed material

<b>ANSWERS</b>	Q.1	A	Q.7	D
	Q.2	C	Q.8	C
	Q.3	C	Q.9	B
	Q.4	D	Q.10	C
	Q.5	C	Q.11	A
	Q.6	C	Q.12	A

## 7

## IDEAL GASES

## 2011

**Q.1** Which of the following is the expression of root mean square speed of a gas having n number of molecules contained in the container?

A)  $\sqrt{\frac{v_1^2 + v_2^2 + \dots + v_x^2}{N}}$

C)  $\sqrt{\frac{v_1 + v_2 + \dots + v_x}{N}}$

B)  $\frac{v_1^2 + v_2^2 + \dots + v_x^2}{N}$

D)  $\frac{v_1 + v_2 + \dots + v_x}{N}$

**Q.2** For a gas of volume V in its equilibrium state, if the pressure does change with time then total kinetic energy of gas is constant because

A) Collisions between gas molecules occur

C) Collisions must be elastic

B) Collisions between gas molecules occur linearly

D) Collisions must be inelastic

## 2012

**Q.3** H<sub>2</sub> and O<sub>2</sub> both are at thermal equilibrium at temperature 300 K. Oxygen molecule is 16 times massive than hydrogen. Root mean square speed of hydrogen is

A) 4 root mean square of oxygen

C) 1/16 root mean square of oxygen

B) 1/4 root mean square of oxygen

D) 1/6 root mean square of oxygen

**Q.4** Which of the following is expression of mean square speed of 'N' gas molecules contained in a cylinder?

A)  $\frac{v_1 + v_2 + \dots + v_x}{N}$

C)  $\sqrt{\frac{v_1 + v_2 + \dots + v_x}{N}}$

B)  $\frac{v_1^2 + v_2^2 + \dots + v_x^2}{N}$

D)  $\sqrt{\frac{v_1^2 + v_2^2 + \dots + v_x^2}{N}}$

## 2013

**Q.5** What is the value of universal gas constant?

A) 8314 Jmol<sup>-1</sup>K<sup>-1</sup>

C) 831.4 Jmol<sup>-1</sup>K<sup>-1</sup>

B) 83.14 Jmol<sup>-1</sup>K<sup>-2</sup>

D) 8.314 Jmol<sup>-1</sup>K<sup>-2</sup>

**Q.6** A gas sample contains three molecules each having speed 1 ms<sup>-1</sup>, 2 ms<sup>-1</sup>, 3 ms<sup>-1</sup>. What is the mean square speed?

A) 14/3 m/s

C) 2 m/s

B) 6 m/s

D)  $\sqrt{14/3}$  m/s

## 2014

**Q.7** A gas containing 'N' number of molecules of a gas having mass of each molecule 'm' is in a cubic container having length of each side 'a'. What is the density of gas contained in cube?

A) N/a<sup>2</sup>

C) Nm/a<sup>3</sup>

B) m/a<sup>3</sup>

D) Na<sup>3</sup>/m

**Q.8** In 'General Gas Equation  $PV=nRT$ ', 'n' represents the number of moles of gas. Which of the following represents the relation of 'n'?

- A)  $n = NN_A$   
B)  $n = N/N_A$

- C)  $n = N_A/N$   
D)  $n = N + N_A$

## 2015

**Q.9** Two sample of gases '1' and '2' are taken at same temperature and pressure but the ratio of number of their volume is  $V_1:V_2 = 2:3$ . What is the ration of number of moles of the gas sample?

- A) 3:2  
B)  $\sqrt{2}:\sqrt{3}$

- C) 4:9  
D) 2:3

**Q.10** Root mean square velocity of a gas having pressure 'P' and density ' $\rho$ ' is given by:

- A)  $\sqrt{\frac{3P}{\rho}}$   
B)  $\frac{3P}{\rho}$

- C)  $\sqrt{\frac{3\rho}{P}}$   
D)  $\frac{3\rho}{P}$

## 2016

**Q.11** The relation  $\frac{R}{N_A} = 1.38 \times 10^{-25} \text{ JK}^{-1}$  in a gas law is known as:

- A) Avogadro's constant  
B) Charles constant

- C) Newton's constant  
D) Boltzmann's constant

**Q.12** The relation ' $PV = nRT$ ' shows which law of physics:

- A) Charles Law  
B) Avogadro's Law

- C) Newton's Constant  
D) Ideal Gas Law

<b>ANSWERS</b>	<b>Q.1</b>	A	<b>Q.7</b>	C
	<b>Q.2</b>	C	<b>Q.8</b>	B
	<b>Q.3</b>	A	<b>Q.9</b>	D
	<b>Q.4</b>	A	<b>Q.10</b>	A
	<b>Q.5</b>	B	<b>Q.11</b>	D
	<b>Q.6</b>	A	<b>Q.12</b>	D

## 8

## HEAT AND THERMODYNAMICS

2011

Q.1 In which of the following, the change in internal energy is more?

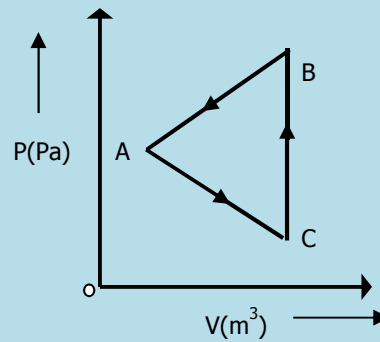
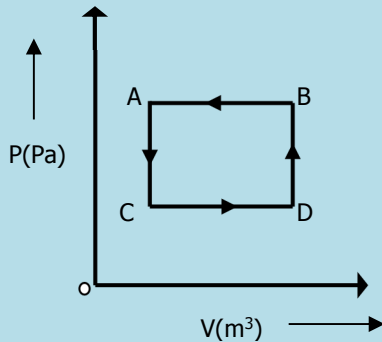

- A) In system A  
B) In system B

- C) Cannot be predicted  
D) Change is zero in both. (both are cyclic)

Q.2 Pressure volume graph of two systems 'A' and 'B' are plotted under isothermal and adiabatic conditions. Which of the following observation of graph represents the two systems?

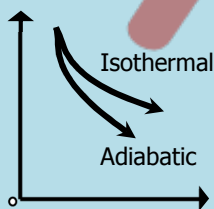

A)

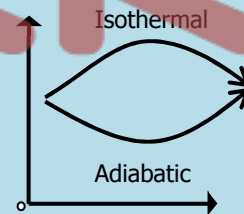

C)

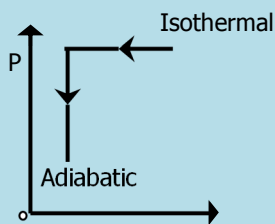

B)

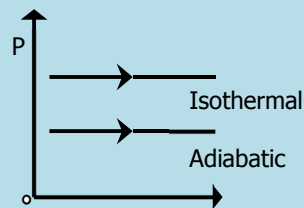

D)

Q.3 Which of the following curve is an isotherm?

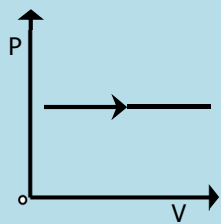

A)

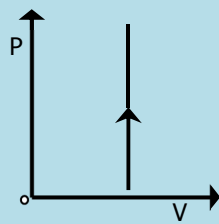

B)

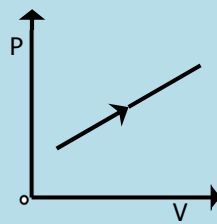

C)

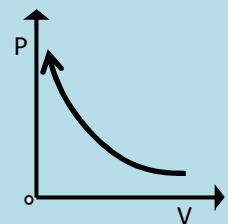

D)



## 2012

- Q.4** If 'Q' is the amount of heat supplied to a system and 'W' is the work done, then change in internal energy can be defined as  
 A)  $Q/W$  C)  $W/Q$   
 B)  $Q - W$  D)  $1 + Q/W$
- Q.5** A heat engine operating according to second law of thermodynamics rejects one fourth of the heat taken from high temperature reservoir. What is the percentage efficiency of heat engine?  
 A) 100% C) 50%  
 B) 25% D) 75%
- Q.6** First law of thermodynamics under adiabatic conditions can be mathematically written as:  
 A)  $Q = W$  C)  $Q = U + W$   
 B)  $Q = \Delta U$  D)  $W = -\Delta U$

## 2013

- Q.7** What is the factor upon which change in internal energy of an ideal gas depends?  
 A) Change in volume C) Change in temperature  
 B) Change in temperature and volume D) Path followed to change internal energy
- Q.8** What will be the mathematical form of first law of thermodynamics for a system whose variation of volume by pressure is shown?

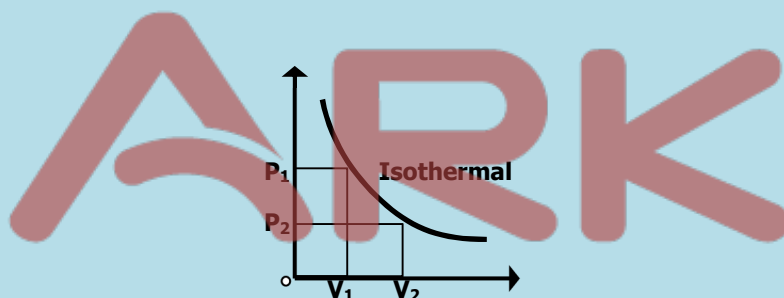

- A)  $Q = U$  C)  $Q = U/W$   
 B)  $U = W$  D)  $Q = W$
- Q.9** For a heat engine 'A' ratio of  $Q_1$  to  $Q_2$  is  $2/3$  while that of heat engine 'B', ratio of  $Q_2$  to  $Q_1$  is  $1/3$ . What is the value  $\eta_A : \eta_B$ ?  
 A) 1:3 C) 2:3  
 B) 1:2 D) 2:1

## 2014

- Q.10** At triple point of water, the pressure of gas is 2680 Pa, by changing 'T' the pressure increases to 4870 Pa. Then 'T' is:  
 A) 496.38 K C) Zero  
 B) 438.96 K D) 496.38 °F
- Q.11** The relation between Celsius and Fahrenheit scales is:  

$$\frac{C}{100} = \frac{F - 32}{180}$$
  
 At what temperature both scales give the same reading?  
 A)  $-100^\circ$  C)  $-180^\circ$   
 B)  $-40^\circ$  D)  $-273^\circ$

- Q.12** A heat engine working according to second law of thermodynamics has 50% efficiency. What will be the temperature of its low temperature reservoir if high temperature reservoir is 327 °C?
- A) 27 °C  
B) 127 °C  
C) 300 °C  
D) 600 °C

## 2015

- Q.13** When the rate of gas changes without change in temperature, the gas is said to undergo:
- A) Isothermal Process  
B) Adiabatic Process  
C) Isochoric Process  
D) Isobaric Process
- Q.14** What is the 273 K on the Celsius scale of temperature?
- A) 0.15 °C  
B) 273.15 °C  
C) -0.15 °C  
D) -273.15 °C
- Q.15** If heat ' $Q_1$ ' is absorbed at temperature ' $T$ ' and heat ' $Q_2$ ' is absorbed at temperature of triple point of water, then unknown temperature of system (in K) is:
- A) 273.16  
B) 273.16  $Q_2/Q_1$   
C) 273.16 Q  
D) 273.16  $Q_1/Q_2$

## 2016

- Q.16** The rapid escape of air from a burst tyre is an example of:
- A) Adiabatic processes  
B) Isothermal process  
C) Cooling process  
D) First law of thermodynamics
- Q.17** Which relation exactly described the isothermal process?
- A)  $Q = W$   
B)  $W = -\Delta U$   
C)  $Q = -\Delta U$   
D)  $Q = \Delta U + W$
- Q.18** If a turbine is working as a heat engine and takes that from hot body (427 °C) and exhausts into a body at 77 °C then what is the possible efficiency?
- A) 50%  
B) 70%  
C) 90%  
D) 95%

<b>ANSWERS</b>	<b>Q.1</b>	D	<b>Q.7</b>	C	<b>Q.13</b>	A
	<b>Q.2</b>	A	<b>Q.8</b>	D	<b>Q.14</b>	C
	<b>Q.3</b>	D	<b>Q.9</b>	B	<b>Q.15</b>	D
	<b>Q.4</b>	B	<b>Q.10</b>	A	<b>Q.16</b>	A
	<b>Q.5</b>	D	<b>Q.11</b>	B	<b>Q.17</b>	A
	<b>Q.6</b>	D	<b>Q.12</b>	A	<b>Q.18</b>	A

## 9

## ELECTRONICS

## 2011

- Q.1 Which of the following is the proper way to study the sinusoidal waveform of the voltage?**  
 A) Voltage is connected to X input and the time base is switched off  
 B) Voltage is connected to Y input and the time base is switched on  
 C) Voltage is connected to Y input and the time base is switched off  
 D) Voltage is connected to X input and the time base is switched on
- Q.2 Electron gun in cathode ray oscilloscope contains**  
 A) Filament, cathode, grid, anode  
 B) Cathode, anode, capacitor, screen  
 C) Emitter, base, collector  
 D) Resistance, capacitor, inductor

## 2012

- Q.3 What is the logic symbol for a NOT Gate?**



- Q.4 The voltage that is applied across X-plates is provided by a circuit called**  
 A) Audio generator  
 B) Time base generator  
 C) Signal generator  
 D) Linear generator

## 2013

- Q.5 Which of the following is the proper way to study the sinusoidal wave form of voltage?**  
 A) Voltage is connected to 'Y' input and time base is switched on.  
 B) Voltage is connected to 'X' input and time base is switched off.  
 C) Voltage is connected to 'Y' input and time base is switched off.  
 D) Voltage is connected to 'X' input and time base is switched on.
- Q.6 What is the output Boolean expression of logic diagram shown in figure below:**

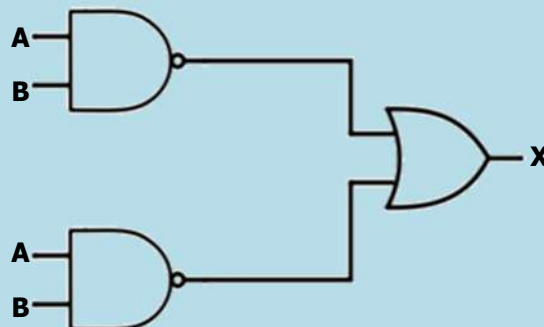

- A)  $(\overline{A + B}).(\overline{A + B})$   
 B)  $(\overline{A + B})(\overline{A + B})$   
 C)  $\overline{A}.B + \overline{A}.\overline{B}$   
 D)  $\overline{A}B + \overline{A}\overline{B}$

## 2014

Q.7 Three NAND gates are connected as shown in the figure.

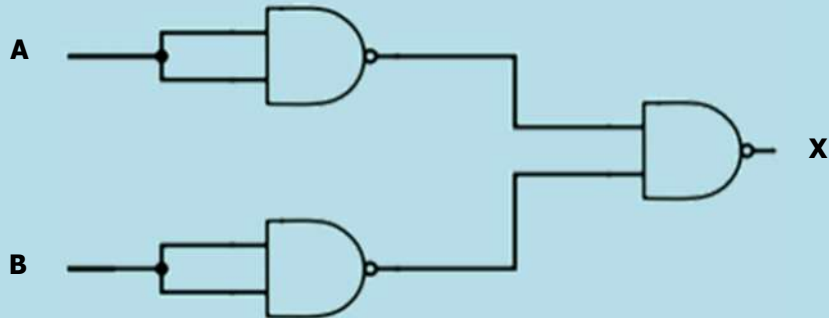

Which of the following logic gate is formed in the connected circuit?

- A) OR  
B) AND  
C) NOR  
D) NAND

Q.8 What is the output of the truth table?

A	B	Output $x = AB + \bar{A}\bar{B}$
0	0	
0	1	
1	0	
1	1	

A)

X
0
0
1
1

C)

X
1
0
0
1

B)

X
1
1
1
0

D)

X
0
1
1
1

## 2015

Q.9 If the fundamental logic gates are connected as:

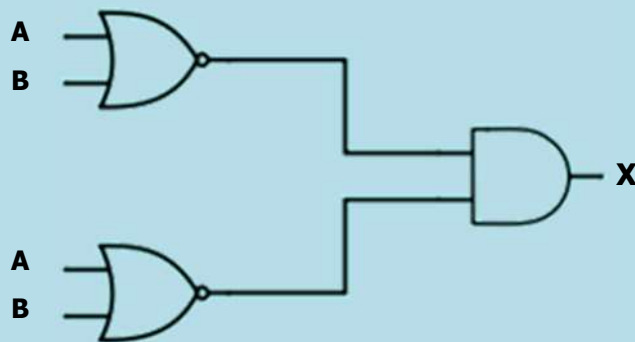

What are the mathematical notation for this logic gate?

- A)  $(\bar{A} + \bar{B}) \cdot (A + B)$   
B)  $(\bar{A} + \bar{B}) \cdot (\bar{A} + \bar{B})$   
C)  $(\bar{A} + \bar{B})(\bar{A} + \bar{B})$   
D)  $\bar{A}\bar{B} + \bar{A}\bar{B}$

Q.10 Which of the following is the truth table for the logic gate;



A)

A	B	Y
0	0	0
0	1	1
1	0	1
1	1	1

C)

A	B	Y
0	0	1
0	1	0
1	0	0
1	1	1

B)

A	B	Y
0	0	0
0	1	0
1	0	0
1	1	1

D)

A	B	Y
0	0	0
0	1	1
1	0	1
1	1	0

2016

Q.11 Which one of the following is the Boolean expression of NAND gate?

A)  $X = A.B$

C)  $X = \overline{A.B}$

B)  $X = A + B$

D)  $X = \overline{A + B}$

Q.12 Which one of the following is the truth table of NAND gate?

A)

A	B	Y
0	0	1
0	1	0
1	0	0
1	1	0

C)

A	B	Y
0	1	1
1	1	0

B)

A	B	Y
0	0	1
0	1	1
1	0	1
1	1	0

D)

A	B	Y
0	0	0
1	1	1

<b>ANSWERS</b>	Q.1	B	Q.7	A
	Q.2	A	Q.8	A
	Q.3	A	Q.9	B
	Q.4	B	Q.10	A
	Q.5	A	Q.11	C
	Q.6	D	Q.12	B

## 10

## CURRENT ELECTRICITY

2011

- Q.1** If 2 A current passes through a resistor when connected to a certain battery. If the resistance is replaced by the double resistance, then the current will become
- A) 2 A  
B) 4 A  
C) 6 A  
D) 1 A

- Q.2** Three resistors each having value 'R' are connected as shown in figure. What is the equivalence resistance between 'X' and 'Y'?

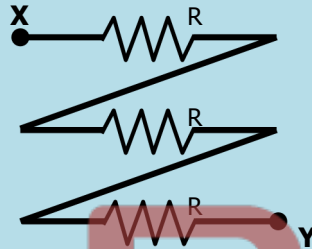

- A) 3R  
B) R

- C)  $R/3$   
D)  $R^3$

- Q.3** Three resistors of resistance  $R_1$ ,  $R_2$  and  $R_3$  are connected as shown in figure. Equivalence resistance is:

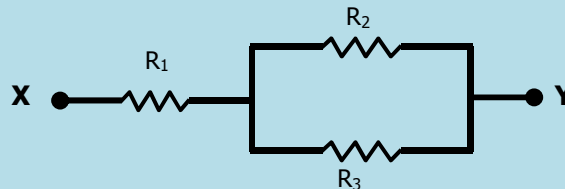

- A)  $R_1 + R_2 + R_3$

- B)  $\frac{R_1 + R_2 + R_3}{R_1 R_2}$

- C)  $\frac{R_1 R_2 + R_2 R_3 + R_2 R_3}{R_1 + R_2}$

- D)  $\frac{R_1 R_2 R_3}{R_2 R_3}$

2012

- Q.4** What will be the effect on the capacitance of a capacitor if area of each plate is doubled while separation between the plates is halved?
- A) Capacitance remains same  
B) Capacitance becomes double  
C) Capacitance becomes four times  
D) Capacitance reduces to half

- Q.5** 10 V potential difference is applied across the plate of 1  $\mu\text{F}$  capacitor. What is the energy stored in capacitor?
- A) 0.5 mJ  
B) 0.05 mJ  
C) 5 mJ  
D) 50 mJ



- Q.11 Three  $6\ \Omega$  are connected as shown in the diagram.

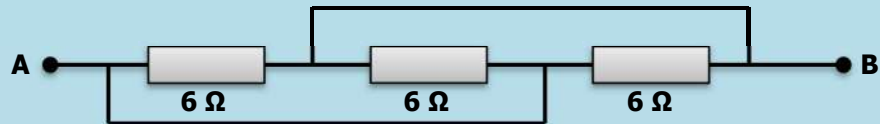

What is the resistance between points 'A' and 'B'?

- A)  $6\ \Omega$  C)  $4\ \Omega$   
 B)  $16\ \Omega$  D)  $2\ \Omega$
- Q.12 The difference between the plates of a parallel plate capacitor is  $2.0\ \text{mm}$  and area of each plate is  $2.0\ \text{m}^2$ . The plates are in a vacuum. A potential difference of  $1.0 \times 10^4\ \text{V}$  is applied across the plates. Find the capacitance.
- A)  $4 \times 10^{-3}\ \text{F}$  C)  $8.85 \times 10^{-9}\ \text{F}$   
 B)  $3.54 \times 10^{-9}\ \text{F}$  D)  $9.0 \times 10^{-9}\ \text{F}$

## 2015

- Q.13 Which combinations of seven identical resistors each of  $2\ \Omega$  gives rise to the resultant of  $10/11\ \Omega$ ?
- A) 5 Parallel, 2 Series C) 3 Parallel, 4 Series  
 B) 4 Parallel, 3 Series D) 2 Parallel, 5 Series
- Q.14 If a resistor having resistance 'R' is cut into three equal parts, then the equivalent of parallel combination is:
- A)  $\frac{6}{R}$  C)  $\frac{R}{9}$   
 B)  $\frac{3}{R}$  D)  $\frac{R}{3}$
- Q.15 The resistance of a piece of wire is  $12\ \Omega$ . It is bent to form an equilateral triangle. What is the equivalent resistance between any two corners of the triangles?
- A)  $1.3\ \Omega$  C)  $4.0\ \Omega$   
 B)  $2.0\ \Omega$  D)  $2.7\ \Omega$

## 2016

- Q.16 If the length, width and separation between the plates of a parallel plate capacitor is doubled then its capacitance becomes:
- A) Double C) Four-times  
 B) Half D) Eight-times
- Q.17 Resistance between two opposite faces of square thin film of area  $1\ \text{mm}^2$  having thickness of  $1\ \mu\text{m}$  if resistivity of material is  $10^{-6}\ \Omega$  will be:
- A)  $1000\ \Omega$  C)  $1\ \Omega$   
 B)  $100\ \Omega$  D)  $10\ \Omega$
- Q.18 Total resistance between 'A' and 'B' in the given circuit is:

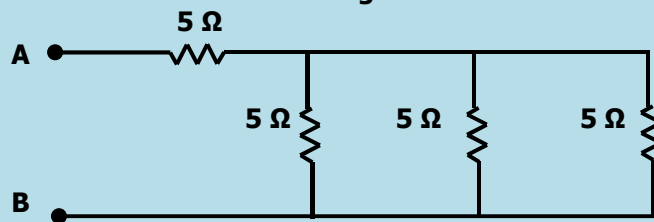

- A)  $5.6\ \Omega$  C)  $0.33\ \Omega$   
 B)  $3.33\ \Omega$  D)  $6.6\ \Omega$



---

<b>ANSWERS</b>	<b>Q.1</b>	D	<b>Q.7</b>	A	<b>Q.13</b>	D
	<b>Q.2</b>	A	<b>Q.8</b>	B	<b>Q.14</b>	C
	<b>Q.3</b>	C	<b>Q.9</b>	C	<b>Q.15</b>	B
	<b>Q.4</b>	C	<b>Q.10</b>	C	<b>Q.16</b>	A
	<b>Q.5</b>	B	<b>Q.11</b>	D	<b>Q.17</b>	<b>X</b>
	<b>Q.6</b>	B	<b>Q.12</b>	C	<b>Q.18</b>	D

---

The logo for ARK, featuring the letters 'A', 'R', and 'K' in a stylized, rounded font. The 'A' is a reddish-brown color, while the 'R' and 'K' are a darker, muted red. The 'A' has a white swoosh underneath it.

## 11

## MAGNETISM &amp; ELECTROMAGNETISM

## 2011

- Q.1** If the number of turns of a solenoid circular coil is doubled, but the current in the coil and radius of the coil remains same, then what will be the magnetic flux density produced by the coil?
- A) Magnetic flux density will be halved  
 B) Magnetic flux density increases by different amount at different points  
 C) Magnetic flux density remains unchanged  
 D) Magnetic flux density will be doubled

- Q.2** Two long parallel wires Wire 1 and Wire 2 repel each other as shown in the figure. What could be the reasons?

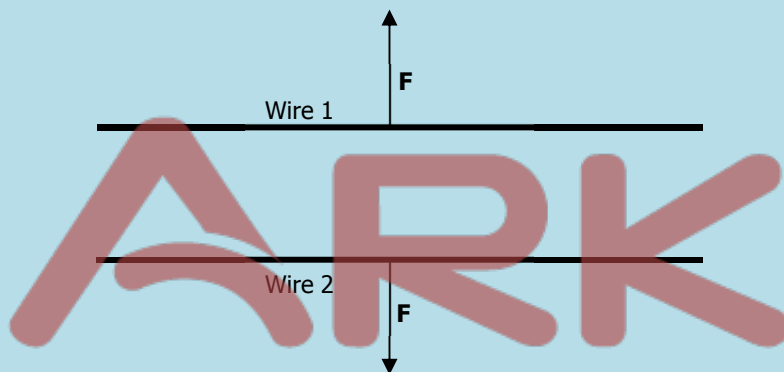

- A) Both carry current in same direction  
 B) Both carry current in opposite direction  
 C) Wire 1 has current, but Wire 2 has no current  
 D) Wire 2 has current, Wire 1 has no current
- Q.3** The diagram shows a wire, carrying a current 'I', placed between the poles of a magnet: In which direction does the force on the wire act?

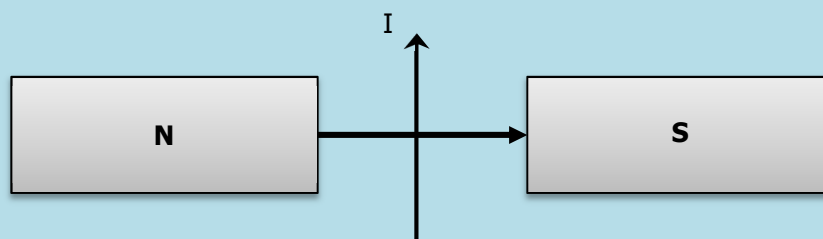

- A) Upwards  
 B) Downwards  
 C) Towards the 'N' pole of the magnet  
 D) Towards the 'S' pole of the magnet

## 2012

- Q.4** A 10 cm long solenoid has 100 turns. What will be the magnetic field inside it along its axis if one micro ampere current is passed through it?
- A)  $4\pi \times 10^{-13}$  tesla  
 B)  $4\pi \times 10^{-7}$  tesla  
 C)  $4\pi \times 10^{-10}$  tesla  
 D)  $4\pi \times 10^{-16}$  tesla

- Q.5** The diagram shows a small magnet hanging on a thread near the end of a solenoid carrying a steady current 'I':

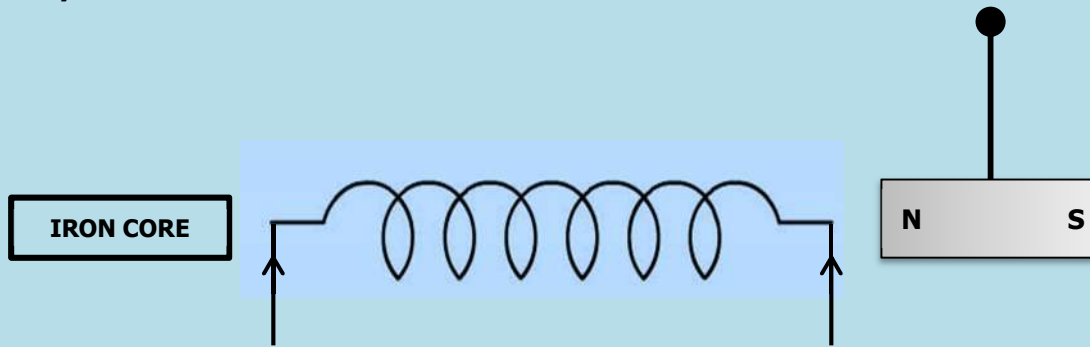

**What happens to the magnet as the iron core is inserted into the solenoid?**

- A) It moves towards solenoid and rotates through  $180^\circ$   
 B) It moves towards the solenoid  
 C) It moves away from solenoid  
 D) It moves away from solenoid and rotates through  $180^\circ$
- Q.6** Two long straight parallel wires held vertically have equal but opposite currents as shown in the figure.

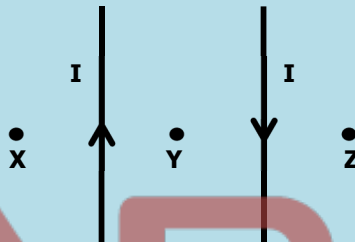

**Which of the following effect will be observed?**

- A) Magnetic field at 'X' is stronger than that at 'Y' and 'Z'  
 B) Magnetic field at 'X' is weaker than that at 'Y' and 'Z'  
 C) Magnetic field at 'X', 'Y' and 'Z' is same  
 D) Magnetic field at 'X' is weaker than that at 'Y' but stronger than that at 'Z'.

## 2013

- Q.7** A solenoid is cut into two halves. Magnetic induction due to same current in each half will be:  
 A) Half of the original  
 B) Double of the original  
 C) Same as original  
 D) Four times of the original
- Q.8** A long straight current carrying conductor has current directed from bottom to top when held vertically. What will be the direction of magnetic field lines when observed from below the conductor?  
 A) Clockwise  
 B) Anti clockwise  
 C) Vertically upward  
 D) Vertically downward
- Q.9** The diagram shows a wire, carrying a current 'I', placed between the poles of magnet: In which direction does the force on the wire act?

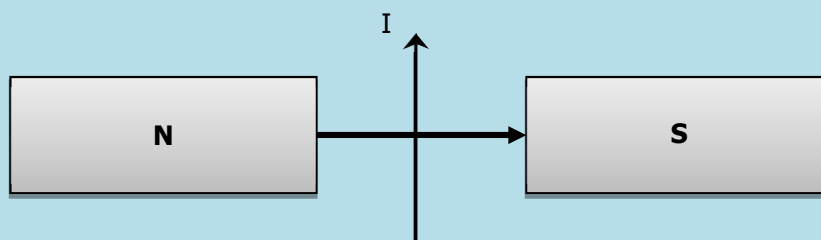

- A) Towards the 'N' pole of the magnet  
 B) Downwards  
 C) Upwards  
 D) Towards the 'S' pole of the magnet

## 2014

- Q.10** A solenoid 15 cm long has 300 turns of wire. A current of 5 A flows through it. What is the magnitude of magnetic field inside the solenoid?  
 A)  $75 \times 10^7$  T  
 B)  $60 \times 10^{+3}$  T  
 C)  $4\pi \times 10^{-3}$  T  
 D)  $750\pi \times 10^{+3}$  T
- Q.11** Due to current in a straight conductor the difference between magnetic field lines  
 A) Increases away from conductor  
 B) Decreases away from conductor  
 C) Increases towards conductor  
 D) Decreases and then increases towards conductor
- Q.12** Magnetic Resonance Imaging (MRI) is used to identify the image of  
 A) Tumors and inflamed tissues  
 B) Blood cells  
 C) Skin cells  
 D) Bone structures

## 2015

- Q.13** Magnetic field strength is measure in:  
 A)  $\text{Wbm}^{-1}$   
 B)  $\text{Wbm}^{-2}$   
 C)  $\text{Wbm}^2$   
 D) Wb
- Q.14** Force on current carrying conductor per unit length is given by:  
 A)  $IL \sin\theta$   
 B)  $ILB$   
 C)  $IL$   
 D)  $IB \sin\theta$
- Q.15** If 'A' is fundamental dimension of ampere then the dimension of magnetic field strength is:  
 A)  $[\text{MT}^2\text{A}^{-2}]$   
 B)  $[\text{MT}^2\text{A}^{-1}]$   
 C)  $[\text{MT}^2\text{L}^2\text{A}^{-1}]$   
 D)  $[\text{MT}^2\text{L}^{-2}\text{A}^{-2}]$

## 2016

- Q.16** 'F' is maximum force acting on a conductor. Now if we change the direction of conductor by making an angle of  $45^\circ$  with the magnetic field then the force becomes:  
 A)  $\frac{F}{2}$   
 B)  $2F$   
 C)  $\frac{F}{\sqrt{2}}$   
 D)  $\sqrt{2} F$
- Q.17** If we doubled all the parameters of the force acting on current carrying conductor and  $\theta = 90^\circ$  then magnetic force becomes:  
 A) Half  
 B) Double  
 C) Eight-times  
 D) Four-times
- Q.18** The force acting on current carrying conductor will be maximum if the angle between magnetic field and conductor is:  
 A)  $0^\circ$   
 B)  $30^\circ$   
 C)  $90^\circ$   
 D)  $60^\circ$

<b>ANSWERS</b>	<b>Q.1</b>	D	<b>Q.7</b>	C	<b>Q.13</b>	B
	<b>Q.2</b>	B	<b>Q.8</b>	A	<b>Q.14</b>	D
	<b>Q.3</b>	B	<b>Q.9</b>	B	<b>Q.15</b>	B
	<b>Q.4</b>	C	<b>Q.10</b>	C	<b>Q.16</b>	C
	<b>Q.5</b>	B	<b>Q.11</b>	A	<b>Q.17</b>	C
	<b>Q.6</b>	A	<b>Q.12</b>	A	<b>Q.18</b>	C

The logo for ARK, featuring the letters 'A', 'R', and 'K' in a stylized, rounded font. The 'A' is a dark red color, while the 'R' and 'K' are a lighter red. A white swoosh is positioned under the 'A'.

## 12

## MODERN PHYSICS

## 2011

- Q.1 In Helium-Neon laser, population inversion of \_\_\_\_\_ atoms is achieved which emit radiations, when they are stimulated to fall at lower level.**
- A) Neon  
B) Helium  
C) Helium and Neon  
D) Chromium
- Q.2 Wavelength of X-rays is the order of:**
- A)  $10^{-6}$  m  
B)  $10^{-10}$  m  
C)  $10^{-13}$  m  
D) 100 m
- Q.3 Laser beam can be used to generate three-dimensional image of object in a process called:**
- A) Computed technology  
B) Computed tomography  
C) Holography  
D) Computerized axial tomography
- Q.4 Which of the following is true for Lasers?**
- A) Electrons are emitted  
B) Stimulated emission of electrons is needed  
C) Coherent monochromatic light is emitted  
D) There is a population inversion of photons
- Q.5 What is meant by spontaneous emission of electrons in solids?**
- A) Electrons being emitted by the solids through photoelectric effect when irradiated with electromagnetic radiation  
B) Incident electrons colliding with electrons in solids and releasing doubling the number of incident electrons  
C) Electrons in solids are emitted without any external stimulus through radiation  
D) Excited electrons going back to lower energy states immediately by releasing energy.
- Q.6 When electrons lose all their kinetic energy in the first collision, the entire kinetic appears as an X-ray photon of energy:**
- A)  $K.E = eV$   
B)  $K.E = \frac{h\lambda_{\min}}{c}$   
C)  $K.E = \frac{hc}{\lambda_{\min}}$   
D)  $K.E = \frac{h}{\lambda_{\max}}$
- Q.7 The characteristic X-ray spectrum is due to:**
- A) The absorption of neutrons by target material  
B) The bombardment of target material by protons  
C) The bombardment of target material by electrons  
D) The bombardment of target material by alpha particles

## 2012

- Q.8 The kinetic energy K.E. with which the electron strikes the target is given by:**
- A)  $K.E. = e^2V$   
B)  $K.E. = hc/\lambda$   
C)  $K.E. = hf^2$   
D)  $K.E. = eV$
- Q.9 X-rays can be produced by bombardment of \_\_\_\_\_ on target metal:**
- A) Protons  
B) Electrons  
C) Neutrons  
D) Alpha particles

- Q.10 LASER is an acronym for:**  
 A) Light amplification by stimulated emission of radiation  
 B) Light annihilation by stimulated emission of radiation  
 C) Light amplitude of stimulated emission of radiation  
 D) Light amplification by stimulated emission of radio
- Q.11 Laser light is monochromatic which means**  
 A) It consists of one ray of light  
 B) It consists of one wavelength  
 C) It consists of carbon monoxide gas  
 D) It consists of photons having 1 eV energy
- Q.12 If an electron in the 'K' shell is removed and an electron from 'L' shell jumps to occupy the hole in the 'K' shell, it emits a photon of energy:**  
 A)  $hf_{K\alpha} = E_L - E_K$   
 B)  $hc = E_L - E_K$   
 C)  $h/\lambda_{K\alpha} = E_L - E_K$   
 D)  $hf_{K\alpha} = E_K - E_L$
- Q.13 Which of the following property must be there in a substance so that it can be used as target in X-ray tube?**  
 A) It must have low melting point  
 B) It must have low atomic number  
 C) It must have high reflecting ability  
 D) It must have high atomic number
- Q.14 Which of the following can be used to produce population inversion for the emission of Laser?**  
 A) Optical pumping  
 B) Optical fibre  
 C) Optical instrument  
 D) Optical polarization

## 2013

- Q.15 X-rays from a given X-ray tube operating under specified conditions have a minimum wavelength. The value of this minimum wavelength could be reduced by:**  
 A) Cooling the target  
 B) Reducing the temperature of the filament  
 C) Increasing the potential difference between the cathode and the target  
 D) Reducing the pressure in the tube
- Q.16 Helium-neon lasers are used for the:**  
 A) Precise measurement of range finding  
 B) Optical fiber communication systems  
 C) Surveying for construction of tunnels  
 D) Welding detached bone of body
- Q.17 What is the type of characteristic X-ray photon whose energy is given by relation ' $hf = E_M - E_K$ '?**  
 A) K – alpha  
 B) M – alpha  
 C) K – beta  
 D) M – beta
- Q.18 Kinetic energy of electrons by applying potential difference  $V_1$  across the x-ray tube is  $KE_1$  while  $V_2$  potential difference produce kinetic energy equal to  $KE_2$ . What will be the value of  $KE_1:KE_2$  if ratio of potential difference  $V_1:V_2 = 2:3$ ?**  
 A) 3:2  
 B) 4:9  
 C) 9:4  
 D) 2:3
- Q.19 What will be the relation for the speed of electron accelerated towards the target in X-ray tube by applying potential difference ' $V$ ', take mass of electron ' $m$ ' and charge on electron ' $e$ '?**  
 A)  $v = \sqrt{\frac{2Ve}{m}}$   
 B)  $v = \sqrt{\frac{2me}{V}}$   
 C)  $v = \sqrt{\frac{2V}{me}}$   
 D)  $v = \sqrt{2meV}$
- Q.20 For what CAT stands in X-ray technology?**  
 A) Capacitor Amplifier Transistor  
 B) Computerized Axial Tomography  
 C) Cathode Anode Technique  
 D) Current Amplification Technology

- Q.21** During the production of LASER, when the excited state  $E_2$  contains more number of atoms than the ground state  $E_1$ , the state is known as:
- A) Population inversion  
B) Ground State  
C) Excited state  
D) Metastable state

**2014**

- Q.22** Stimulated emission of two photons 'A' and 'B' during LASER action is shown in figure:

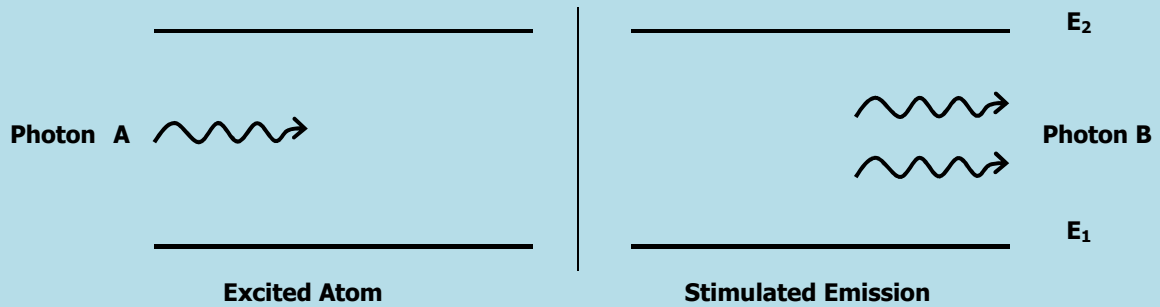

**What is the relation of wavelengths of two photons?**

- A)  $\lambda_A = \lambda_B$   
B)  $\lambda_A > \lambda_B$   
C)  $\lambda_A < \lambda_B$   
D)  $\lambda_A = 2\lambda_B$
- Q.23** Bones absorb greater amount of incident X-rays than flesh. This is because of the fact that
- A) Bones lie between the flesh  
B) Bones are light in color  
C) Bones contain material of low densities  
D) Bones contain material of high densities
- Q.24** Which of the following techniques is the practical application of X-rays?
- A) Magnetic Resonance Imaging  
B) Ultrasonography  
C) Computerized Axial Topography  
D) Positron Emission Tomography
- Q.25** Which one of the following spectra is most typical of the output of an X-ray tube?

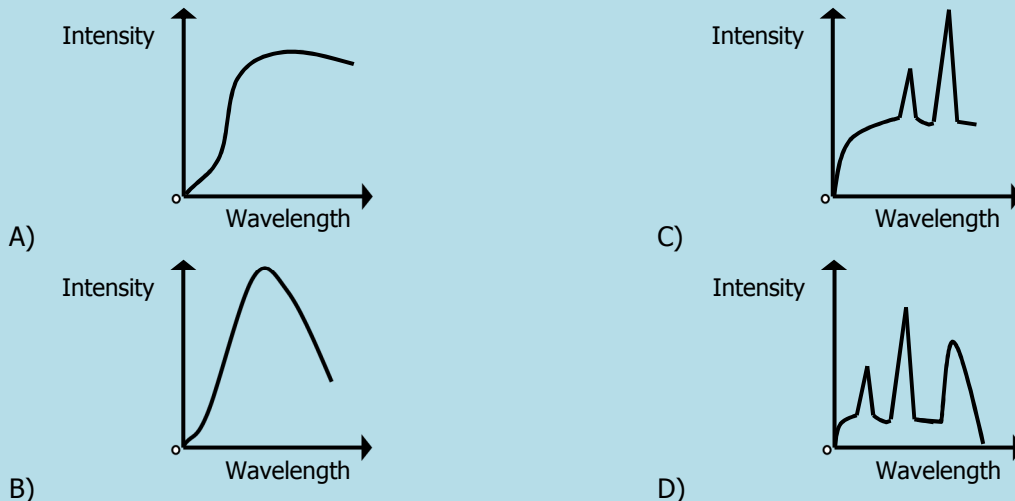

- Q.26** Which one of the following has the largest energy content?
- A)  $\gamma$ -rays  
B) X-rays  
C) Infra-red radiations  
D) Ultra-violet radiations
- Q.27** What will be the energy of accelerated electron used to produce X-rays when the accelerating potential is 2 kV?
- A)  $2 \times 10^{-19}$  J  
B)  $1.6 \times 10^{-19}$  J  
C)  $3.2 \times 10^{19}$  J  
D)  $3.2 \times 10^{-16}$  J



- Q.28 Process of generating three dimensional images of objects by using laser beam is called**  
 A) Photography  
 B) 3-D cinema  
 C) Holography  
 D) Tomography

## 2015

- Q.29 In the case when the electrons lose all their kinetic energy (K.E.) in the first collision, the X-ray photon emitted has which of the following set of frequency and wavelength?**  
 A)  $f_{\max}$ ,  $\lambda_{\min}$   
 B)  $f_{\max}$ ,  $\lambda_{\max}$   
 C)  $f_{\min}$ ,  $\lambda_{\max}$   
 D)  $f_{\min}$ ,  $\lambda_{\min}$

- Q.30 The potential difference between target and cathode of an X-rays tube is 20 kV and current is 20 mA. What is the  $\lambda_{\min}$  of the emitted X-ray?**  
 A)  $6.19 \times 10^{-4}$  m  
 B)  $6.19 \times 10^{-14}$  m  
 C)  $6.19 \times 10^{-11}$  m  
 D)  $6.19 \times 10^{-19}$  m

- Q.31 Which of the following spectra is most typical of the output of an X-ray tube?**

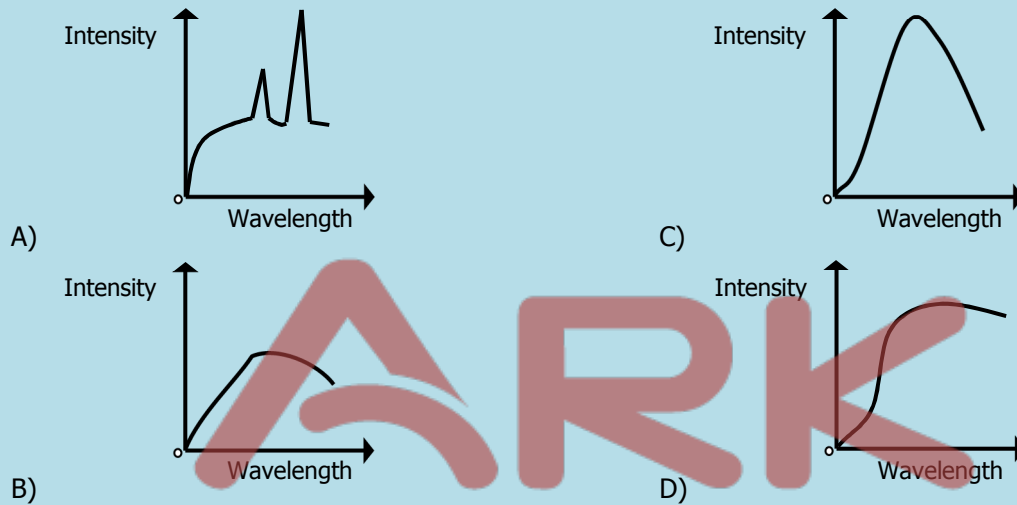

- Q.32 One method of creating an inverted population is known as \_\_\_\_\_ and consist of illuminating the laser material with light.**  
 A) Optical Pumping  
 B) Excitation  
 C) Bremsstrahlung  
 D) Holography

- Q.33 In population inversion (Ruby Laser) atoms can reside in the excited state for:**  
 A)  $10^{-11}$   
 B)  $10^{-8}$   
 C)  $10^{-3}$   
 D)  $10^{+3}$

- Q.34 If electrons of charge 'e' moving with velocity 'v' are accelerated through a potential difference 'V' and strike a metal target, then velocity of electrons is:**

A)  $\frac{Ve}{m}$   
 B)  $\sqrt{\frac{Ve}{m}}$   
 C)  $\sqrt{\frac{Ve}{2m}}$   
 D)  $\sqrt{\frac{2Ve}{m}}$

- Q.35 In X-ray tube, electrons after being accelerated through velocity 'v' strike the target, then the wavelength of emitted X-rays is:**

A) Not greater than  $\frac{hc}{eV}$   
 B) Not less than  $\frac{hc}{eV}$   
 C) Equal to the  $\frac{h}{mV}$   
 D) Equal to  $\frac{hc}{eV}$

## 2016

**Q.36 The shadow of the bones in X-rays photographic film appears lighter than the surrounding flesh due to:**

- A) Bones reflect greater amount of X-rays  
 B) Bones absorb less amount of X-rays  
 C) Bones absorb greater amount of X-rays  
 D) Bones totally reflect X-rays

**Q.37 The atom is excited to an energy level  $E_i$  from its ground state energy level  $E_o$ , the wavelength of the radiations emitted is:**

- A)  $\frac{(E_o - E_i)}{hc}$   
 B)  $\frac{(E_i - E_o)}{hc}$   
 C)  $\frac{hc}{(E_i - E_o)}$   
 D)  $\frac{E_i}{hc} - \frac{E_o}{hc}$

**Q.38 Which one of the following gas is the lasing or active medium in the laser tube?**

- A) Hydrogen  
 B) Helium  
 C) Neon  
 D) Carbon dioxide

**Q.39 The target of X-ray tube is made up of which metal?**

- A) Iron  
 B) Nickel  
 C) Brass  
 D) Tungsten

**Q.40 The X-rays consists of:**

- A) High energy proton  
 B) High energy electrons  
 C) High energy  $\gamma$ -rays  
 D) High energy photons

**Q.41 Which of the following graph represents the output of an X-ray?**

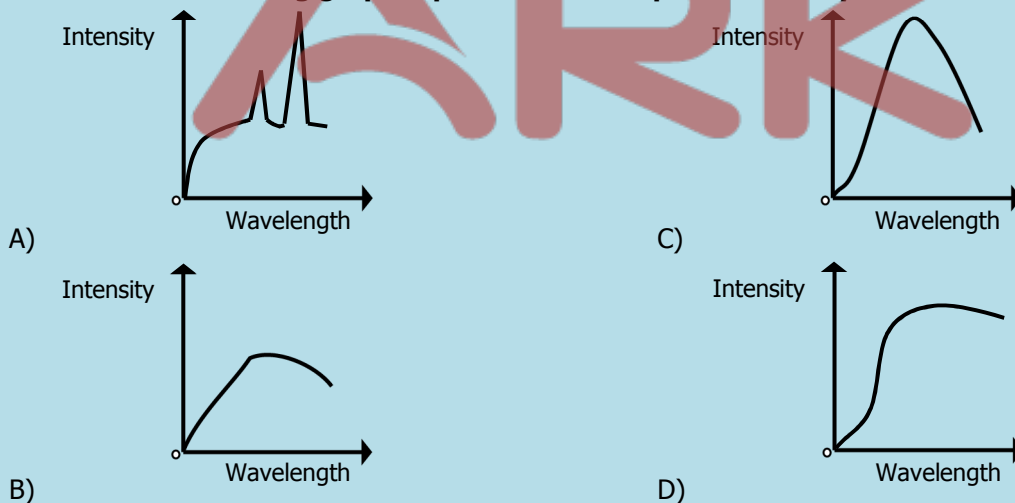

**Q.42 The continuous spectrum of X-ray is formed due to:**

- A) Characteristics of X-rays  
 B) Bremsstrahlung X-ray  
 C) Soft X-ray  
 D) Hard X-ray

<b>ANSWERS</b>	<b>Q.1</b>	A	<b>Q.15</b>	C	<b>Q.29</b>	A
	<b>Q.2</b>	B	<b>Q.16</b>	C	<b>Q.30</b>	C
	<b>Q.3</b>	C	<b>Q.17</b>	C	<b>Q.31</b>	A
	<b>Q.4</b>	D	<b>Q.18</b>	D	<b>Q.32</b>	A
	<b>Q.5</b>	D	<b>Q.19</b>	A	<b>Q.33</b>	B
	<b>Q.6</b>	A	<b>Q.20</b>	B	<b>Q.34</b>	D
	<b>Q.7</b>	C	<b>Q.21</b>	A	<b>Q.35</b>	D
	<b>Q.8</b>	D	<b>Q.22</b>	A	<b>Q.36</b>	B
	<b>Q.9</b>	B	<b>Q.23</b>	D	<b>Q.37</b>	C
	<b>Q.10</b>	A	<b>Q.24</b>	C	<b>Q.38</b>	C
	<b>Q.11</b>	B	<b>Q.25</b>	C	<b>Q.39</b>	D
	<b>Q.12</b>	A	<b>Q.26</b>	A	<b>Q.40</b>	D
	<b>Q.13</b>	D	<b>Q.27</b>	D	<b>Q.41</b>	A
	<b>Q.14</b>	A	<b>Q.28</b>	C	<b>Q.42</b>	B

ARK

## 13

## NUCLEAR PHYSICS

## 2011

- Q.1 Ionizing capability of gamma rays is:**  
 A) Equal to alpha and beta particle  
 B) Less than alpha but greater than beta particles  
 C) Less than both alpha and beta particles  
 D) Less than beta but greater than alpha particles
- Q.2 Half-life of a radioactive element is:**  
 A) Inversely proportional to square of decay constant  
 B) Directly proportional to square of decay constant  
 C) Directly proportional to decay constant  
 D) Inversely proportional to decay constant
- Q.3 The transformation of a neutron into proton in the nucleus gives rise to emission of:**  
 A) Beta particles  
 B) Alpha particles  
 C) Gamma particles  
 D) X-rays
- Q.4 The ratio of the rate of decay of a parent atom to the number of radioactive nuclei present at that time is equal to:**  
 A) Half-life of radioactive element  
 B) Mean life  
 C) Decay constant of radioactive element  
 D) Activity of radioactive element
- Q.5 Which one of the following particle is emitted as a result of nuclear reaction?**  

$$\text{Ra}^{226} \longrightarrow \text{Rn}^{222}$$
  
 A) Beta  
 B) Alpha  
 C) Gamma rays  
 D) One alpha and one beta
- Q.6 Which of following is used to estimate the circulation of blood in a patient?**  
 A) Carbon-14  
 B) Carbon-12  
 C) Phosphorus-32  
 D) Sodium-24
- Q.7 For the radiotherapy of a patient, it is required to double the absorbed dose in gray. What step must be taken?**  
 A) Energy must be quadrated  
 B) Energy must be halved  
 C) Energy must be raised four times  
 D) Energy must be doubled

## 2012

- Q.8 What is the charge on alpha particles emitted during the phenomenon of radioactivity?**  
 A) +e  
 B) -e  
 C) -2e  
 D) +2e
- Q.9 A radioactive nuclide decays by emitting an alpha particle, a beta particle and a gamma ray photon, the change in the nucleon number will be:**  
 A) -4  
 B) -1  
 C) -2  
 D) -3
- Q.10 A half-life of sodium-24 is \_\_\_\_\_ which is used to estimate the volume of blood in a patient:**  
 A) 6 hours  
 B) 15 hours  
 C) 8 hours  
 D) 15 days

**Q.11 Which of the following is unit of absorbed dose?**

- A) Sievert  
B) Gray  
C) Roentgen  
D) Curie

**Q.12 In a radioactive phenomenon observation shown in figure where  $\alpha$  deviates lesser than  $\beta$  in some electric or magnetic field (not shown in figure). What is the reason of less deviation of  $\alpha$ ?**



- A)  $\alpha$  is charged particle  
B)  $\alpha$  is neutral particle  
C)  $\alpha$  is heavier particle  
D)  $\alpha$  is lighter particle

**Q.13 The isotope of Iodine-131 is used in the treatment of**

- A) Blood cancer  
B) Bone cancer  
C) Lung tumor  
D) Thyroid cancer

**Q.14 Which of the following effect is observed due to emission of  $\beta^-$  during the phenomenon of radioactivity?**

- A) A increases by 1 and Z remains same  
B) Z increases by 1 and A remains same  
C) Z decreases by 1 and A remains same  
D) A decreases by 1 and Z remains same

2013

**Q.15 In cloud chamber the path of  $\beta$ -particles is:**

- A) Straight, thick, short  
B) Thin, wavy, shorter  
C) Thin, wavy, longer  
D) Thin, straight, short

**Q.16 Among the three types of radioactive radiation, which have strongest penetration power?**

- A) Alpha  
B) Gamma  
C) Beta  
D) All have same penetration power

**Q.17 Emission of alpha decay from a radioactive substance causes:**

- A) Decreases in 'Z' by 4 and decreases in 'A' by 2  
B) Decreases in 'A' by 1 and 'Z' remains same  
C) Decreases in 'Z' by 1 and 'A' remains same  
D) Decreases in 'A' by 4 and decreases in 'Z' by 2

**Q.18 10 Joule of energy is absorbed by 10-gram mass from a radioactive source. What is the absorbed dose?**

- A) 1 gray  
B) 1000 gray  
C) 10 gray  
D) 100 gray

**Q.19 Isotopes are those nuclei of an element that have:**

- A) Same mass number but different atomic number  
B) Same mass number as well as atomic number  
C) Different mass number as well as atomic number  
D) same atomic number but different mass number

**Q.20 Which one of the following emission takes place in a nuclear reaction?**



- A) Alpha  
B) Gamma  
C) Beta  
D) Photons

**Q.21 Emission of radiation from radioactive substance is:**

- A) Dependent on both temperature and pressure  
 B) Independent of temperature but dependent on pressure  
 C) Independent of both temperature and Pressure  
 D) Independent of pressure but dependent on temperature

**2014**

**Q.22 Which one of the following isotopes of Iodine is used for the treatment of thyroid cancer?**

- A) I - 113  
 B) I - 120  
 C) I - 131  
 D) I - 140

**Q.23 A beta ( $\beta$ ) particle is a fast-moving electron. During a  $\beta$  – decay how the atomic number and mass number of a nucleus change?**

	Atomic Number	Mass Number
A)	Remains the same	Increases by one
B)	Increases by one	Decreases by two
C)	Increases by one	Remains the same
D)	Decreases by two	Decreases by four

**Q.24 A Uranium isotope  ${}_{92}^{232}\text{U}$  undergoes one  $\alpha$ –decay and one  ${}_{-1}^0\beta$  – decay. What is the final product?**

- A) 90  
 B) 92  
 C) 89  
 D) 88

**Q.25 A naturally occurring radioactive element decays two alpha particles. Which one of the following represents status of daughter element with respect to mass number 'A' and charge number 'Z'?**

- A) 'Z' decreases by 4 and 'A' decreases by 2  
 B) 'Z' decreases by 2 and 'A' decreases by 4  
 C) 'Z' decreases by 4 and 'A' decreases by 8  
 D) 'Z' decreases by 8 and 'A' decreases by 4

**Q.26 A radioactive isotope 'W' decays to 'X' which decays to 'Y' and 'Y' decays to 'Z' as represented by the figure below:****What is the change in the atomic number from 'W' to 'Z'?**

- A) Increases by 3  
 B) Decreases by 3  
 C) Increases by 5  
 D) Decreases by 5

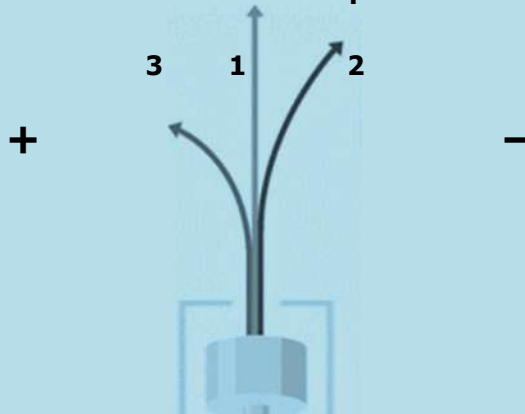
**Q.27 Three paths of radioactive radiations are observed as shown in the figure in the presence of electric field. Which type of radiation is shown in path 1?**

- A) Alpha  
 B) Beta  
 C) Gamma  
 D) Cathode rays

**Q.28 What is the absorbed dose 'D' of a sample of 2 kg which is given an amount of 100 J of radioactive energy?**

- A) 200 Gy  
 B) 102 Gy  
 C) 50 Gy  
 D) 98 Gy

## 2015

- Q.29** In the reaction,  ${}^{234}_{92}\text{Th} \rightarrow {}^{234}_{91}\text{Y} + {}^0_{-1}\text{e}$  the electron  ${}^0_{-1}\text{e}$  emits from the  
 A) 1<sup>st</sup> Orbit  
 B) 2<sup>nd</sup> Orbit  
 C) Nucleus  
 D) Valence Shell
- Q.30** According to the equation  ${}^A_Z\text{X} \rightarrow \text{Y} + 3\alpha$  particles, what are the atomic and mass numbers of 'Y'?  
 A)  $Z - 6, A - 12$   
 B)  $Z - 2, A - 4$   
 C)  $Z + 1, A$   
 D)  $Z + 3, A$
- Q.31** A certain radioactive nuclide of mass number 'x' decays by  $\beta$ -emission and  $\alpha$ -emission to a second nuclide of mass number 't'. Which of following correctly relates 'x' and 't'?  
 A)  $x = t + 4$   
 B)  $x = t - 4$   
 C)  $x - 3 = t$   
 D)  $x - 1 = t$
- Q.32** During the decay of radioactive isotopes  ${}^{232}_{90}\text{X}$  to a stable isotope, six  $\alpha$ -particles and four  $\beta$ -particles are emitted, what is the atomic number 'Z' and mass number 'A' of the stable isotopes.  
 A)  $Z = 70, A = 220$   
 B)  $Z = 78, A = 212$   
 C)  $Z = 82, A = 212$   
 D)  $Z = 82, A = 208$
- Q.33** Cobalt 60 is used in medicine and is an intense source of:  
 A)  $\alpha$ -particles  
 B)  $\beta$ -particles  
 C)  $\gamma$ -rays  
 D) Neutrons
- Q.34** Sodium 24 has half-life of 15 hour and it is used in medicine to estimate:  
 A) Kidney Function  
 B) Plasma Blood Volume  
 C) Iron in Plasma  
 D) Thyroid Function
- Q.35** In Wilson Cloud Chamber which of the following tracks represented  $\beta$ -particles?

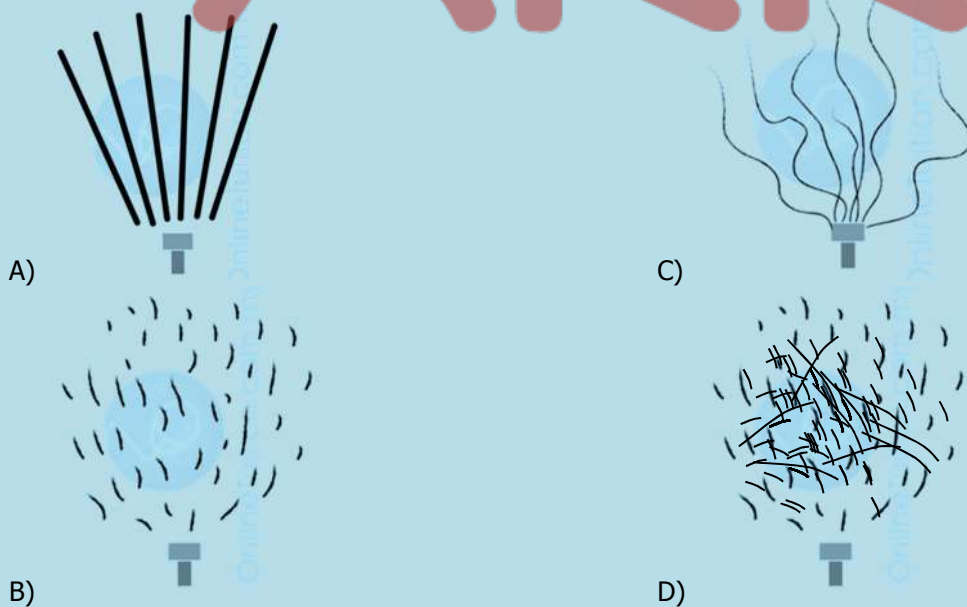

## 2016

- Q.36** Wavelength of  $\gamma$ -rays is:  
 A) Equal to the X-rays  
 B) Shorter to the X-rays  
 C) Longer to the X-rays  
 D) Boarder to the X-rays

- Q.37 Thorium is transformed after the transmission of  $\beta$ -particle into:**  
 A) Bismuth C) Polonium  
 B) Protactinium D) Palladium
- Q.38 Emission of  $\gamma$ -rays from radioactive element results into:**  
 A) Bismuth C) Polonium  
 B) Protactinium D) Palladium
- Q.39 The relation between decay constant ' $\lambda$ ' and half-life ' $T_{1/2}$ ' of radioactive substance is:**  
 A)  $\lambda = \frac{1}{T_{1/2}}$  C)  $\lambda = T_{1/2}$   
 B)  $\lambda = 0.693 T_{1/2}$  D)  $\lambda = \frac{0.693}{T_{1/2}}$
- Q.40 Radioisotope which is used to combat cancer of thyroid gland is:**  
 A) Iodine-131 C) Strontium-90  
 B) Phosphorous-32 D) Cobalt-60
- Q.41 Sodium-24 is used for:**  
 A) Sterilization C) Skin Cancer  
 B) Study of circulation of blood D) Thyroid Cancer
- Q.42 Energy radiation absorbed at the rate of one joule per kilogram is called:**  
 A) 1 Rad C) 1 Yellow  
 B) 1 Sievert D) 1 Gray

<b>ANSWERS</b>	<b>Q.1</b>	C	<b>Q.15</b>	C	<b>Q.29</b>	C
	<b>Q.2</b>	D	<b>Q.16</b>	B	<b>Q.30</b>	A
	<b>Q.3</b>	A	<b>Q.17</b>	D	<b>Q.31</b>	A
	<b>Q.4</b>	C	<b>Q.18</b>	B	<b>Q.32</b>	D
	<b>Q.5</b>	B	<b>Q.19</b>	D	<b>Q.33</b>	C
	<b>Q.6</b>	D	<b>Q.20</b>	C	<b>Q.34</b>	B
	<b>Q.7</b>	D	<b>Q.21</b>	C	<b>Q.35</b>	C
	<b>Q.8</b>	D	<b>Q.22</b>	C	<b>Q.36</b>	C
	<b>Q.9</b>	A	<b>Q.23</b>	C	<b>Q.37</b>	B
	<b>Q.10</b>	B	<b>Q.24</b>	B	<b>Q.38</b>	C
	<b>Q.11</b>	B	<b>Q.25</b>	C	<b>Q.39</b>	D
	<b>Q.12</b>	C	<b>Q.26</b>	B	<b>Q.40</b>	A
	<b>Q.13</b>	D	<b>Q.27</b>	C	<b>Q.41</b>	B
	<b>Q.14</b>	B	<b>Q.28</b>	C	<b>Q.42</b>	D



2011-2016

# MEDICAL COLLEGE APTITUDE TEST - CHEMISTRY

UHS, LAHORE

PAST PAPERS UNIT WISE MCQS

Ali Raza  
ARK



# Table of Specification



NO.	UNIT NAME	MCQs
<b>PHYSICAL CHEMISTRY</b>		
1A.	FUNDAMENTAL CONCEPTS	2
2A.	STATES OF MATTER	2
3A.	ATOMIC STRUCTURE	2
4A.	CHEMICAL BONDING	2
5A.	CHEMICAL ENERGETICS	2
6A.	SOLUTIONS	2
7A.	ELECTROCHEMISTRY	2
8A.	CHEMICAL EQUILIBRIUM	2
9A.	REACTION KINETICS	2
<b>INORGANIC CHEMISTRY</b>		
1B.	PERIODS	2
2B.	GROUPS	2
3B.	TRANSITION ELEMENTS	2
4B.	ELEMENTS OF BIOLOGICAL IMPORTANCE	4
<b>ORGANIC CHEMISTRY</b>		
1C.	FUNDAMENTAL PRINCIPLES	2
2C.	HYDROCARBON	2
3C.	ALKYL HALIDES	2
4C.	ALCOHOLS AND PHENOLS	4
5C.	ALDEHYDES AND KETONES	3
6C.	CARBOXYLIC ACIDS	3
7C.	AMINO ACIDS	6
8C.	MACROMOLECULES	6
9C.	ENVIRONMENTAL CHEMISTRY	2
<b>TOTAL:</b>		<b>58</b>



# Contents

NO.	UNIT NAME	PAGE NO.
<b>PHYSICAL CHEMISTRY</b>		
1A.	FUNDAMENTAL CONCEPTS	5
2A.	STATES OF MATTER	7
3A.	ATOMIC STRUCTURE	9
4A.	CHEMICAL BONDING	11
5A.	CHEMICAL ENERGETICS	13
6A.	SOLUTIONS	15
7A.	ELECTROCHEMISTRY	17
8A.	CHEMICAL EQUILIBRIUM	20
9A.	REACTION KINETICS	22
<b>INORGANIC CHEMISTRY</b>		
1B.	PERIODS	25
2B.	GROUPS	27
3B.	TRANSITION ELEMENTS	29
4B.	ELEMENTS OF BIOLOGICAL IMPORTANCE	31
<b>ORGANIC CHEMISTRY</b>		
1C.	FUNDAMENTAL PRINCIPLES	35
2C.	HYDROCARBON	38
3C.	ALKYL HALIDES	40
4C.	ALCOHOLS AND PHENOLS	42
5C.	ALDEHYDES AND KETONES	46
6C.	CARBOXYLIC ACIDS	50
7C.	AMINO ACIDS	53
8C.	MACROMOLECULES	59
9C.	ENVIRONMENTAL CHEMISTRY	63



# PHYSICAL CHEMISTRY

## 1A

## FUNDAMENTAL CONCEPTS

## 2011

- Q.1 In mass spectrometer, detector or collector measures the:**  
 A) Masses of isotopes  
 B) Percentages of isotopes  
 C) Relative abundances of isotopes  
 D) Mass numbers of isotopes
- Q.2 How many 'Cl' (chlorine) atoms are in two moles of chlorine?**  
 A)  $2 \times 6.02 \times 10^{23}$  atoms  
 B)  $35.5 \times 6.02 \times 10^{23}$  atoms  
 C)  $2 \times 10^{23}$  atoms  
 D)  $2 \times 6.02 \times 10^{23}$  atoms

## 2012

- Q.3 An organic compound has empirical formula  $C_3H_3O$ , if molar mass of compound is  $110.15 \text{ gmol}^{-1}$ . The molecular formula of this organic compound is (A, of C=12, H=1.008 and O=16)**  
 A)  $C_6H_6O_2$   
 B)  $C_3H_3O$   
 C)  $C_9H_9O_3$   
 D)  $C_6H_6O_3$
- Q.4 When 8 grams (4 moles) of  $H_2$  react with 2 moles of  $O_2$ , how many moles of water will be formed?**  
 A) Five  
 B) Four  
 C) Six  
 D) Three

## 2013

- Q.5 Hydrogen burns in chlorine to produce hydrogen chloride. The ratio of masses of reactants in chemical reaction is:**
- $$H_2 + Cl_2 \longrightarrow 2HCl$$
- A) 1:35.5  
 B) 2:35.5  
 C) 1:71  
 D) 2:70
- Q.6 A sample of Neon is found to exist as  $^{20}\text{Ne}$ ,  $^{21}\text{Ne}$ ,  $^{22}\text{Ne}$ . Mass spectrum of 'Ne' is as follow:**

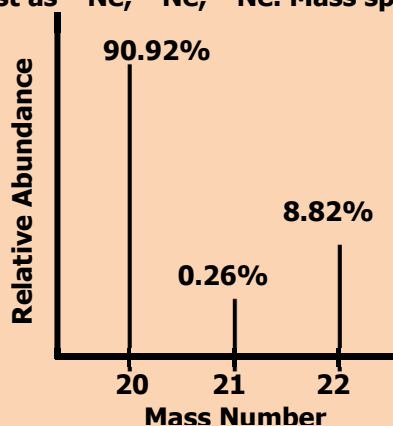

**What is the relative atomic mass (A, value) of Neon?**

- A) 20.18  
 B) 20.28  
 C) 20.10  
 D) 20.22

## 2014

- Q.7** A polymer of empirical formula  $\text{CH}_2$  has molar mass of  $28000 \text{ g mol}^{-1}$ . Its molecular formula will be  
 A) 100 times that of its empirical formula  
 B) 200 times that of its empirical formula  
 C) 500 times that of its empirical formula  
 D) 2000 times that of its empirical formula
- Q.8** The number of molecules in 9 g of ice ( $\text{H}_2\text{O}$ ) is  
 A)  $6.02 \times 10^{24}$   
 B)  $6.02 \times 10^{23}$   
 C)  $3.01 \times 10^{24}$   
 D)  $3.01 \times 10^{23}$

## 2015

- Q.9** How many moles of sodium are present in 0.1 g of sodium?  
 A)  $4.3 \times 10^{-3}$   
 B)  $4.03 \times 10^{-1}$   
 C)  $4.01 \times 10^{-2}$   
 D)  $4.3 \times 10^{-2}$
- Q.10** With the help of spectral data given calculate the mass of Neon and encircle the best option. (Percentage of  $^{20}\text{Ne}$ ,  $^{21}\text{Ne}$  and  $^{22}\text{Ne}$  are 90.92%, 0.26% and 8.82% respectively).  
 A) 22.18 amu  
 B) 21.18 amu  
 C) 20.18 amu  
 D) 22.20 amu

## 2016

- Q.11** The substance for the separation of isotopes is firstly converted into the:  
 A) Neutral state  
 B) Free state  
 C) Vapour state  
 D) Charged state
- Q.12** The number of moles of  $\text{CO}_2$  which contain 8.00 gm of oxygen is:  
 A) 0.75  
 B) 1.50  
 C) 0.25  
 D) 1.00

<b>ANSWERS</b>	<b>Q.1</b>	C	<b>Q.7</b>	D
	<b>Q.2</b>	D	<b>Q.8</b>	D
	<b>Q.3</b>	A	<b>Q.9</b>	A
	<b>Q.4</b>	B	<b>Q.10</b>	C
	<b>Q.5</b>	A	<b>Q.11</b>	C
	<b>Q.6</b>	B	<b>Q.12</b>	C

## 2A

## STATES OF MATTER

## 2011

- Q.1 Melting point of water is higher than petrol, because intermolecular forces in water are:**  
 A) Weaker than petrol  
 B) Stronger than petrol  
 C) Same as in petrol  
 D) Negligible
- Q.2 DNA molecule is double stranded, in which two chains of DNA are twisted around each other by:**  
 A) Hydrogen bonds  
 B) Vander Waal's force  
 C) Covalent bonds  
 D) Dative bonds

## 2012

- Q.3 The number of molecules in 22.4 dm<sup>3</sup> of H<sub>2</sub> gas at 0 °C and 1 atm are**  
 A)  $60.2 \times 10^{23}$   
 B)  $6.02 \times 10^{22}$   
 C)  $6.02 \times 10^{25}$   
 D)  $6.02 \times 10^{22}$
- Q.4 Correct order of boiling points of the given liquid is**  
 A) H<sub>2</sub>O > HF > HCl > NH<sub>3</sub>  
 B) HF > H<sub>2</sub>O > HCl > NH<sub>3</sub>  
 C) H<sub>2</sub>O > HF > NH<sub>3</sub> > HCl  
 D) HF > H<sub>2</sub>O > NH<sub>3</sub> > HCl

## 2013

- Q.5 The coordination number of Na<sup>+</sup> in NaCl crystal is:**  
 A) 6  
 B) 2  
 C) 4  
 D) 8
- Q.6 There are four gases H<sub>2</sub>, He, N<sub>2</sub> and CO<sub>2</sub> at 0 °C. Which gas shows greater non-ideal behavior?**  
 A) He  
 B) CO<sub>2</sub>  
 C) H<sub>2</sub>  
 D) N<sub>2</sub>

## 2014

- Q.7 Ice is less dense than water at:**  
 A) 0 °C  
 B) 4 °C  
 C) -4 °C  
 D) 2 °C
- Q.8 At a given temperature and pressure, the one which shows marked deviation from ideal behavior is**  
 A) N<sub>2</sub>  
 B) N<sub>3</sub>  
 C) CO<sub>2</sub>  
 D) He

## 2015

- Q.9 If the volume of a gas collected at a temperature of 600 °C and pressure of  $1.05 \times 10^5 \text{ Nm}^{-2}$  is 60 dm<sup>3</sup>, what would be the volume of gas at STP ( $P=1.01 \times 10^3 \text{ Nm}^{-2}$ ,  $T = 273 \text{ K}$ )?**  
 A) 25 cm<sup>3</sup>  
 B) 75 cm<sup>3</sup>  
 C) 100 cm<sup>3</sup>  
 D) 51 cm<sup>3</sup>

**Q.10** Which graph represents Boyle's law?

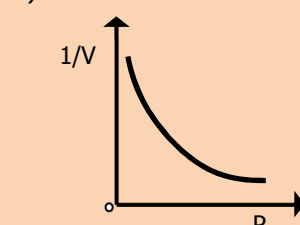
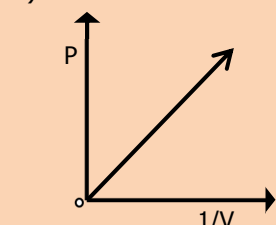
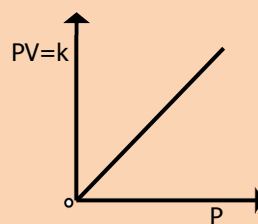
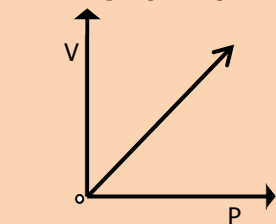

## 2016

**Q.11** London dispersion forces are the only forces present among the:

- A) Molecules of  $\text{H}_2\text{O}$  in liquid state  
 B) Molecules of  $\text{HCl}$  gas  
 C) Atoms of helium in gaseous state at high temperature  
 D) Molecules of solid chlorine

**Q.12** Electrical conductivity of graphite is greater in one direction than in other due to:

- A) Isomorphism  
 B) Cleavage plane  
 C) Anisotropy  
 D) Symmetry

<b>ANSWERS</b>	<b>Q.1</b>	B	<b>Q.7</b>	A
	<b>Q.2</b>	A	<b>Q.8</b>	C
	<b>Q.3</b>	D	<b>Q.9</b>	D
	<b>Q.4</b>	C	<b>Q.10</b>	B
	<b>Q.5</b>	A	<b>Q.11</b>	C
	<b>Q.6</b>	B	<b>Q.12</b>	C



## 3A

## ATOMIC STRUCTURE

## 2011

- Q.1 The elements for which the value of ionization energy is low, can:**  
 A) Gain electrons readily  
 B) Gains electron with difficulty  
 C) Loss electrons less readily  
 D) Lose electrons readily
- Q.2 The nature of cathode rays in discharge tube:**  
 A) Depends on the nature of gas taken in the discharge tube  
 B) Depends upon the nature of cathode in discharge tube  
 C) Is independent of the nature pf the gas in discharge tube  
 D) Depends upon the nature of anode in the discharge tube

## 2012

- Q.3 The relative energies of 4s, 4p and 3d orbitals are in the order**  
 A)  $3d < 4p < 4s$   
 B)  $4s < 3d < 4p$   
 C)  $4p < 4s < 3d$   
 D)  $4p < 3d < 4s$
- Q.4 With increase in the value of Principal Quantum Number 'n', the shape of the s-orbitals remains the same although their sizes**  
 A) Decrease  
 B) Increase  
 C) Remain the same  
 D) May or may not remain the same

## 2013

- Q.5 Correct order of energy in the given subshells is:**  
 A)  $5s > 3d > 3p > 4s$   
 B)  $5s > 3d > 4s > 3p$   
 C)  $3p > 3d > 5s > 4s$   
 D)  $3p > 3d > 4s > 5s$
- Q.60 Number of electrons in the outermost shell of chloride ion ( $\text{Cl}^-$ ) is:**  
 A) 17  
 B) 3  
 C) 1  
 D) 8

## 2014

- Q.7 According to the number of protons, neutrons and electrons given in the table, which one of the following options is correct?**

Species	Proton	Neutron	Electron
As	33	42	30
Ga	31	39	28
Ca	20	20	20

- A)  $\text{As}^{+3}$ ,  $\text{Ga}^{+3}$ , Ca  
 B)  $\text{As}^{+1}$ ,  $\text{Ga}^{+2}$ , Ca  
 C)  $\text{As}^{+3}$ ,  $\text{Ga}^{+3}$ ,  $\text{Ca}^{+2}$   
 D)  $\text{As}^{+1}$ , Ga,  $\text{Ca}^{+2}$

- Q.8** If the  $e/m$  value of electron is  $1.7588 \times 10^{11}$  coulombs  $\text{Kg}^{-1}$ , then what would be the mass of electron in grams (charge on electron is  $1.6022 \times 10^{-19}$  coulombs)?
- A)  $9.1095 \times 10^{-31}$  g  
 B)  $91.095 \times 10^{-31}$  g  
 C)  $9.1095 \times 10^{-28}$  g  
 D)  $0.919095 \times 10^{-33}$  g

## 2015

- Q.9** Which one of the following pairs has the same electronic configuration as possessed by Neon (Ne-10)?
- A)  $\text{Na}^+$ ,  $\text{Cl}^-$   
 B)  $\text{K}^+$ ,  $\text{Cl}^-$   
 C)  $\text{Na}^+$ ,  $\text{Mg}^{2+}$   
 D)  $\text{Na}^+$ ,  $\text{F}^-$
- Q.10** There are four orbitals s, p, d and f. Which order is correct with respect to the increasing energy of the orbitals?
- A)  $4s < 4p < 4d < 4f$   
 B)  $4p < 4s < 4f < 4d$   
 C)  $4s < 4f < 4p < 4d$   
 D)  $4f < 4s < 4d < 4p$

## 2016

- Q.11** Number of neutrons in  ${}^{66}_{30}\text{Zn}$  will be:
- A) 30  
 B) 35  
 C) 38  
 D) 36
- Q.12** The maximum number of electrons in electronic configuration can be calculated by using formula:
- A)  $2l + 1$   
 B)  $2n^2 + 2$   
 C)  $2n^2$   
 D)  $2n^2 + 1$

ANSWERS	Q.1	D	Q.7	A
	Q.2	C	Q.8	A
	Q.3	B	Q.9	D
	Q.4	B	Q.10	A
	Q.5	B	Q.11	C
	Q.6	D	Q.12	A

## 4A

## CHEMICAL BONDING

## 2011

- Q.1 The ability of an atom in a covalent bond to attract the bonding electrons is called:**  
 A) Ionization energy  
 B) Ionic bond energy  
 C) Electronegativity  
 D) Electron affinity
- Q.2 The paramagnetic character of a substance is due to:**  
 A) Bond pairs of electrons  
 B) Lone pairs of electrons  
 C) Unpaired electrons in atom or molecule  
 D) Paired electrons in valence shells of electrons

## 2012

- Q.3 The angle between unhybridized p-orbital and three  $sp^2$  hybrid orbitals of each carbon atom in ether is:**  
 A)  $120^\circ$   
 B)  $90^\circ$   
 C)  $109.5^\circ$   
 D)  $180^\circ$
- Q.4 In 'H-F' bond electronegativity difference is '1.9'. What is the type of this bond?**  
 A) Polar covalent bond  
 B) Non-polar covalent bond  
 C) Pi ( $\pi$ ) bond  
 D) Co-ordinate covalent bond

## 2013

- Q.5 According to valence shell electron pair repulsion theory, the repulsive forces between the electron pair of central atom of molecule are in the order:**  
 A) Lone Pair - Lone-Pair > Lone Pair - Bond Pair > Bond Pair - Bond Pair  
 B) Lone Pair - Bond Pair > Lone Pair - Lone Pair > Bond Pair - Bond Pair  
 C) Bond Pair - Bond Pair > Lone Pair - Lone Pair > Lone Pair - Bond Pair  
 D) One Pair - Bond Pair > Bond Pair - Bond Pair > Lone Pair - Lone Pair
- Q.6 In crystal lattice of ice, each O-atom of water molecule is attached to:**  
 A) Four H-atoms  
 B) Three H-atoms  
 C) One H-atom  
 D) Two H-atoms

## 2014

- Q.7 The suitable representation of dot structure of chlorine molecule is:**
- A)  $\text{:}\ddot{\text{Cl}}\text{:}\text{:}\ddot{\text{Cl}}\text{:}$
- B)  $\text{:}\ddot{\text{Cl}}\text{:}\text{:}\ddot{\text{Cl}}\text{:}$
- C)  $\ddot{\text{Cl}}\parallel\ddot{\text{Cl}}$
- D)  $\ddot{\text{Cl}}\text{:}\ddot{\text{Cl}}$

- Q.8** When the two partially filled atomic orbitals overlap in such a way that the probability of finding electron is maximum around the line joining the two nuclei, the result is the formation of
- A) Sigma Bond  
B) Pi-Bond  
C) Hydrogen Bond  
D) Metallic Bond

## 2015

- Q.9** Which one of the following hydrogen bonds is stronger than others?
- A)  $\text{N}^{\delta-}-\text{H}^{\delta+} \cdots \cdots \text{N}^{\delta-}-\text{H}^{\delta+}$   
B)  $\text{F}^{\delta-}-\text{H}^{\delta+} \cdots \cdots \text{F}^{\delta-}-\text{H}^{\delta+}$   
C)  $\text{O}^{\delta-}-\text{H}^{\delta+} \cdots \cdots \text{O}^{\delta-}-\text{H}^{\delta+}$   
D)  $\text{N}^{\delta-}-\text{H}^{\delta+} \cdots \cdots \text{O}^{\delta-}-\text{H}^{\delta+}$

- Q.10** Which of the following is the correct dot and cross diagram of bonding between two chlorine atoms?

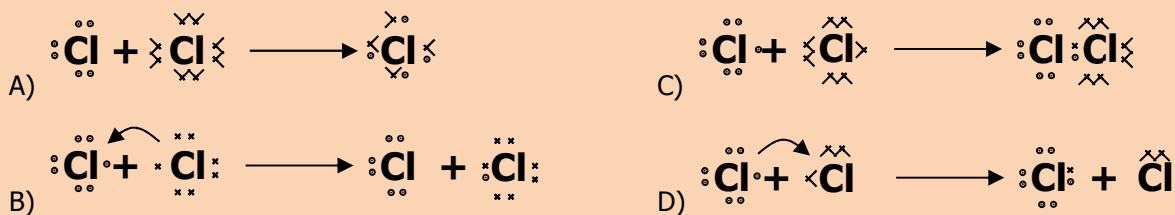

## 2016

Q.11

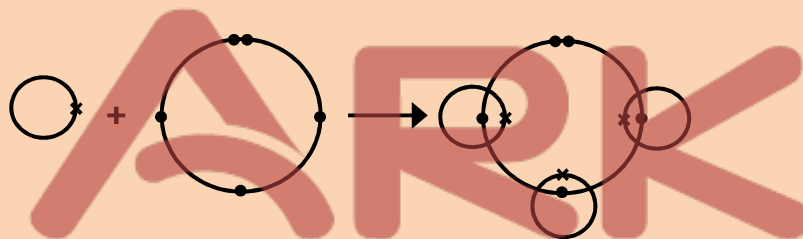

Choose the right molecule.

- A)  $\text{CH}_3$   
B)  $\text{CO}$   
C)  $\text{H}_2\text{O}$   
D)  $\text{NH}_3$

Q.12

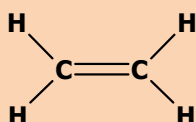
Calculate the number of  $\sigma$  bonds and  $\pi$  bonds in the molecule.

- A)  $1\pi$  and  $5\sigma$  bonds  
B)  $2\pi$  and  $4\sigma$  bonds  
C)  $3\pi$  and  $3\sigma$  bonds  
D)  $6\pi$  and  $6\sigma$  bonds

<b>ANSWERS</b>	<b>Q.1</b>	C	<b>Q.7</b>	B
	<b>Q.2</b>	C	<b>Q.8</b>	A
	<b>Q.3</b>	B	<b>Q.9</b>	B
	<b>Q.4</b>	A	<b>Q.10</b>	C
	<b>Q.5</b>	A	<b>Q.11</b>	D
	<b>Q.6</b>	A	<b>Q.12</b>	A

## 5A

## CHEMICAL ENERGETICS

## 2011

- Q.1 Lattice energy of an ionic crystal is the enthalpy of:**  
 A) Combustion  
 B) Dissociation  
 C) Dissolution  
 D) Formation
- Q.2 In standard enthalpy of atomization, heat of the surrounding:**  
 A) Remains unchanged  
 B) Increases  
 C) Increases than decreases  
 D) Decreases

## 2012

- Q.3 'ΔH' will be given a negative sign in**  
 A) Exothermic reactions  
 B) Decomposition reactions  
 C) Dissociation reaction  
 D) Endothermic reactions
- Q.4 Lattice energy of an ionic crystal is the enthalpy of**  
 A) Combustion  
 B) Dissociation  
 C) Dissolution  
 D) Formation

## 2013

- Q.5 Heat of formation (ΔH<sub>f</sub><sup>o</sup>) for CO<sub>2</sub> is:**  
 A) -394 kJ/mole  
 B) +394 kJ/mole  
 C) -294 kJ/mole  
 D) -390 kJ/mole
- Q.6 Reactants have high energy than products in:**  
 A) Exothermic reactions  
 B) Endothermic reactions  
 C) Photochemical reactions  
 D) Non-spontaneous reactions

## 2014

- Q.7**  $2\text{H}_2 + \text{O}_2 \longrightarrow 2\text{H}_2\text{O}$        $\Delta\text{H} = +285.5 \text{ kJ mol}^{-1}$   
**What will be the enthalpy change in the above reaction?**  
 A) 205.5 kJ/mol  
 B) Zero kJ/mol  
 C) -205.5 kJ/mol  
 D) 1 kJ/mol
- Q.8 Combustion of graphite to form CO<sub>2</sub> can be done by two ways. Reactions are given as follows:**
- |                                                                 |                                               |
|-----------------------------------------------------------------|-----------------------------------------------|
| $\text{C} + \text{O}_2 \longrightarrow \text{CO}_2$             | $\Delta\text{H} = -393.7 \text{ kJ mol}^{-1}$ |
| $\text{C} + \frac{1}{2}\text{O}_2 \longrightarrow \text{CO}$    | $\Delta\text{H} = ?$                          |
| $\text{CO} + \frac{1}{2}\text{O}_2 \longrightarrow \text{CO}_2$ | $\Delta\text{H} = -283 \text{ kJ mol}^{-1}$   |
- What will be enthalpy of formation of CO?**  
 A) -676 kJ mol<sup>-1</sup>  
 B) -110 kJ mol<sup>-1</sup>  
 C) 110 kJ mol<sup>-1</sup>  
 D) 676 kJ mol<sup>-1</sup>

## 2015

**Q.9** The equation that represents standard enthalpy of atomization of hydrogen is:

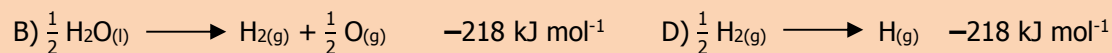
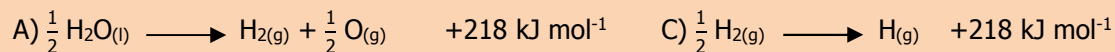

**Q.10** Standard enthalpy of combustion of graphite at 25 °C is  $-393.51 \text{ kJ mol}^{-1}$  and that of diamond is  $-395.41 \text{ kJ mol}^{-1}$ . The enthalpy change for graphite is:

A)  $-1.91$

C)  $-2.1$

B)  $+2.1$

D)  $+1.91$

## 2016

**Q.11**  $\frac{1}{2} \text{H}_2(g) \longrightarrow \text{H}(g) \quad \Delta H = 218 \text{ kJ mol}^{-1}$

In this reaction,  $\Delta H$  will be called:

A) Enthalpy of atomization

C) Enthalpy of formation

B) Enthalpy of decomposition

D) Enthalpy of the dissociation

**Q.12**  $\text{Mg} + \frac{1}{2} \text{O}_2(g) \longrightarrow \text{MgO}(g) + -692 \text{ kJ mol}^{-1}$  at STP.

Enthalpy of the above reaction will be called:

A)  $\Delta H^\circ_{\text{at}}$

C)  $\Delta H^\circ_{\text{sol}}$

B)  $\Delta H^\circ_{\text{s}}$

D)  $\Delta H^\circ_{\text{i}}$

<b>ANSWERS</b>	<b>Q.1</b>	D	<b>Q.7</b>	C
	<b>Q.2</b>	D	<b>Q.8</b>	B
	<b>Q.3</b>	A	<b>Q.9</b>	C
	<b>Q.4</b>	D	<b>Q.10</b>	D
	<b>Q.5</b>	A	<b>Q.11</b>	A
	<b>Q.6</b>	A	<b>Q.12</b>	D

## 6A

## SOLUTIONS

## 2011

**Q.1 Mole fraction of any compound is the ratio of moles of all components in a:**

- A) Compound  
B) Solution  
C) Molecule  
D) Solid

**Q.2 Molarity is defined as the number of moles of any substance dissolved:**

- A) Per  $\text{dm}^3$  of water  
B) In one gram of water  
C) Per  $\text{m}^3$  of water  
D) In 100 ml of water

## 2012

**Q.3 As number of solute particles increases, freezing point of the solution:**

- A) Remains the same  
B) Increases  
C) First increases, then decreases  
D) Decreases

**Q.4 Boiling point constants help us to determine**

- A) Molar masses  
B) Volumes  
C) Pressures  
D) Masses

## 2013

**Q.5 If 18.0 g of glucose is dissolved in 1 kg of water, boiling point of this solution should be:**

- A) 100.52 °C  
B) 100.00 °C  
C) 100.052 °C  
D) Less than 100 °C

**Q.6 Molal freezing point constant of water is:**

- A) 1.86  
B) 2.86  
C) 11.86  
D) 0.52

## 2014

**Q.7 The vapor pressure lines for pure as well as solutions of different concentrations are shown. Which line represents pure water?**

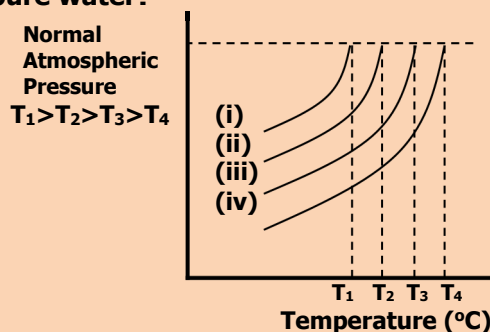

- A) (i)  
B) (ii)  
C) (iii)  
D) (iv)

- Q.8** One mole of glucose was dissolved in 1 kg of water, ethanol, ether and benzene separately and the molal boiling point constant of each individual solution was found to be 0.52, 1.75, 2.16 and 2.70 in the units of  $^{\circ}\text{C kg mol}^{-1}$  respectively. Which of the following figures shows benzene as solvent in solution?

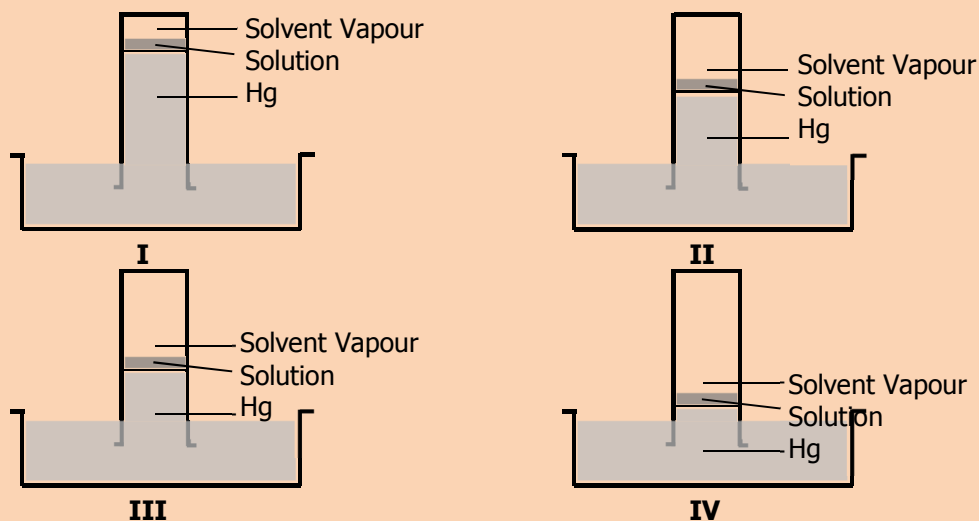

- A) I  
B) II

- C) III  
D) IV

## 2015

- Q.9** 10.0 grams of glucose are dissolved in water to make  $100\text{ cm}^3$  of its solution, its molarity is:  
A) 0.55  
B) 0.1  
C) 10  
D) 1
- Q.10** Given solution contains 16.0 g of  $\text{CH}_3\text{OH}$ , 92.0 g of  $\text{C}_2\text{H}_5\text{OH}$  and 36 g of water. Which statement about mole fraction of the components is true?  
A) Mole fraction of  $\text{CH}_3\text{OH}$  is highest among all components  
B) Mole fraction of  $\text{C}_2\text{H}_5\text{OH}$  and  $\text{H}_2\text{O}$  is the same  
C) Mole fraction of  $\text{CH}_3\text{OH}$  and  $\text{C}_2\text{H}_5\text{OH}$  is same  
D) Mole fraction of  $\text{H}_2\text{O}$  is the lowest among all

## 2016

- Q.11** Freezing point will also be defined as that temperature at which its solid and liquid phases have the same:  
A) Concentration  
B) Ratio between the particles  
C) Vapour pressure  
D) Attraction between the phases
- Q.12** What mass of NaOH is present in 0.5 mol of sodium hydroxide?  
A) 40 gm  
B) 2.5 gm  
C) 15 gm  
D) 20 gm

<b>ANSWERS</b>	<b>Q.1</b>	B	<b>Q.5</b>	C	<b>Q.9</b>	A
	<b>Q.2</b>	A	<b>Q.6</b>	A	<b>Q.10</b>	B
	<b>Q.3</b>	D	<b>Q.7</b>	A	<b>Q.11</b>	C
	<b>Q.4</b>	A	<b>Q.8</b>	A	<b>Q.12</b>	D



7A

## ELECTROCHEMISTRY

## 2011

- Q.1 In electrolytic cell, a salt bridge is used in order to:**
- A) Pass the electric current  
B) Prevent the flow of ions  
C) Mix solution of two half cells  
D) Allow movement of ions b/w two half cells
- Q.2 In all oxidation reactions, atoms of an element in a chemical species lose electrons and increase their:**
- A) Oxidation states  
B) Reductions  
C) Electrode  
D) Negative charges

## 2012

- Q.3 In electrolysis of aqueous  $\text{CuCl}_2$ , the metal deposited at cathode is**
- A) Sodium  
B) Aluminium  
C) Lead  
D) Copper
- Q.4 In  $\text{MgCl}_2$ , the oxidation state of 'Cl' is**
- A) Zero  
B) +2  
C) -2  
D) -1

## 2013

- Q.5 In the figure given below, the electron flow in external circuit is from:**

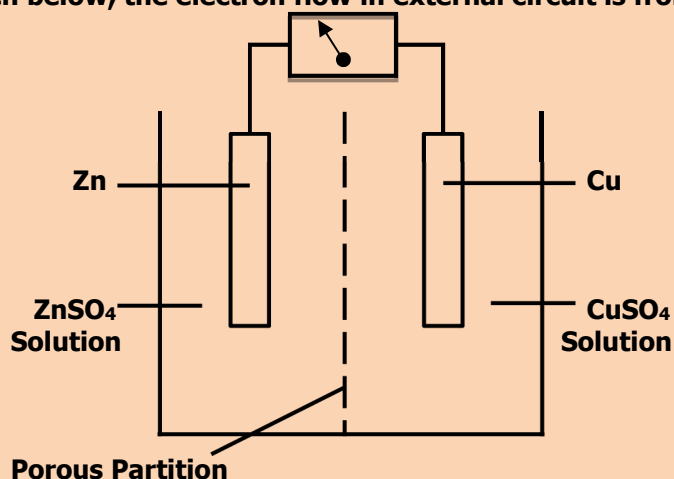

- A) Copper to zinc electrode  
B) Right to left  
C) Porous partition to zinc electrode  
D) Zinc to copper electrode
- Q.6 Which one of the following is a redox reaction?**
- A)  $\text{NaCl} + \text{AgNO}_3 \longrightarrow \text{NaNO}_3 + \text{AgCl}$   
B)  $2\text{Cl}^- \longrightarrow \text{Cl}_2 + 2\text{e}^-$   
C)  $2\text{Na} + \text{Cl}_2 \longrightarrow 2\text{NaCl}$   
D)  $\text{Na}^+ + 1\text{e}^- \longrightarrow \text{Na}$

## 2014

**Q.7** In  $\text{SO}_4^{2-}$  the oxidation number of Sulphur is

- A) -8  
B) +8  
C) -6  
D) +6

**Q.8** Coinage metals Cu, Ag, and Au are the least reactive because they have:

- A) Negative reduction potential  
B) Positive reduction potential  
C) Negative oxidation potential  
D) Positive oxidation potential

## 2015

**Q.9** Study the following facts

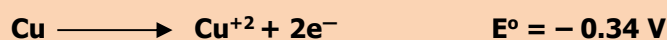
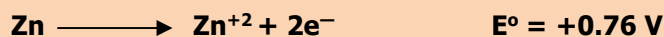

- A)  $\text{Cu} + \text{Zn}^{2+} \longrightarrow \text{Cu}^{2+} + \text{Zn}$   
B)  $\text{Cu}^{2+} + \text{Zn}^{2+} \longrightarrow \text{Cu} + \text{Zn}$   
C)  $\text{Cu}^{2+} + \text{Zn} \longrightarrow \text{Cu} + \text{Zn}^{2+}$   
D)  $\text{Cu}^{2+} + \text{Zn}^{2+} \longrightarrow \text{Cu} + \text{Zn}^{2+}$

**Q.10** Keeping in mind the electrode potential, which one of the following reactions is feasible?

- A)  $\text{Zn}^{2+} + \text{Cu} \longrightarrow \text{Cu}^{2+} + \text{Zn}$   
B)  $\text{Zn} + \text{MgSO}_4 \longrightarrow \text{ZnSO}_4 + \text{Mg}$   
C)  $\text{Fe} + \text{CuSO}_4 \longrightarrow \text{FeSO}_4 + \text{Cu}$   
D)  $\text{Cd} + \text{MgSO}_4 \longrightarrow \text{CdSO}_4 + \text{Mg}$

## 2016

**Q.11**

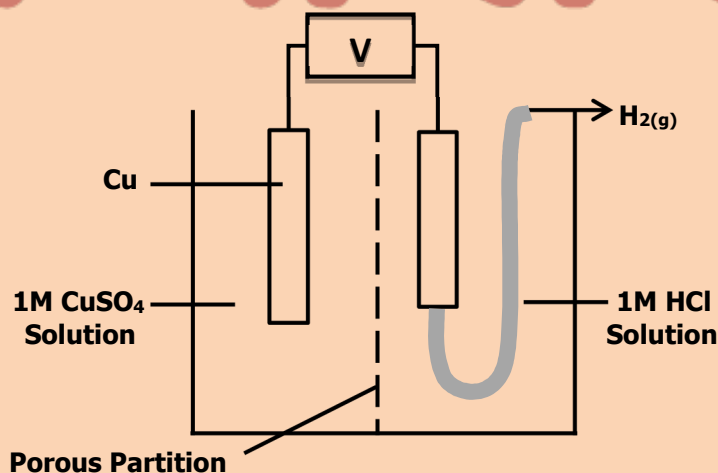

The diagram shows a galvanic cell. The current will flow from:

- A) Hydrogen electrode to copper electrode  
B) Copper electrode to hydrogen electrode  
C) Hydrogen electrode to HCl solution  
D)  $\text{CuSO}_4$  solution to hydrogen electrode

**Q.12** Study the following redox reaction:



- A) Manganese is oxidized from +7 to +2  
B) Chlorine ions are reduced from -1 to zero  
C) Chlorine is reduced from zero to -1  
D) Manganese is reduced from +7 to +2

<b>ANSWERS</b>	<b>Q.1</b>	D	<b>Q.7</b>	D
	<b>Q.2</b>	A	<b>Q.8</b>	B
	<b>Q.3</b>	D	<b>Q.9</b>	C
	<b>Q.4</b>	D	<b>Q.10</b>	C
	<b>Q.5</b>	D	<b>Q.11</b>	A
	<b>Q.6</b>	C	<b>Q.12</b>	D



## 8A

## CHEMICAL EQUILIBRIUM

## 2011

- Q.1 In 'AgCl' solution. Some salt of NaCl is added, 'AgCl' will be precipitated due to:**
- A) Solubility  
B) Electrolyte  
C) Unsaturation effect  
D) Common ion effect
- Q.2 'Ka' for an acid is higher, the stronger is the acid; relate the strength an acid with 'pKa'**
- A) Higher pKa, weaker the acid  
B) Lower pKa, stronger the acid  
C) pKa has no relation with acid strength  
D) Both A and B

## 2012

- Q.3 Formation of NH<sub>3</sub> is reversible and exothermic process, what will happen on cooling?**
- A) More reactant will form  
B) More N<sub>2</sub> will be formed  
C) More H<sub>2</sub> will be formed  
D) More product (NH<sub>3</sub>) will be formed
- Q.4 A buffer solution is that which resists/minimizes the change in**
- A) pOH  
B) pH  
C) pKa  
D) pKb

## 2013

- Q.5 The chemical substance, when dissolved in water, gives "H<sup>+</sup>" is called:**
- A) Acid  
B) Base  
C) Amphoteric  
D) Neutral
- Q.6 The 'pH' of our blood is:**
- A) 6.7 – 8  
B) 7.9  
C) 7.5  
D) 7.35 – 7.4

## 2014

- Q.7 The value of equilibrium constant (K<sub>c</sub>) for the reaction  $2\text{HF}_{(s)} \rightleftharpoons \text{H}_{2(g)} + \text{F}_{2(g)}$  is  $10^{-13}$  at 2000 °C. Calculate the value of K<sub>p</sub> for this reaction:**
- A)  $2 \times 10^{-13}$   
B)  $10^{-13}$   
C)  $186 \times 10^{-13}$   
D)  $3.48 \times 10^{-9}$
- Q.8 What will be the pH of a solution of NaOH with a concentration of  $10^{-3}$  M?**
- A) 3  
B) 14  
C) 11  
D) 7

## 2015

**Q.9** What is the correct relation between pH and pK?

A)  $\text{pH} = \text{pKa} + \log \left[ \frac{\text{Acid}}{\text{Base}} \right]$                       C)  $\text{pH} = \text{pKa} - \log \left[ \frac{\text{Base}}{\text{Acid}} \right]$

B)  $\text{pH} = \text{pKa} - \log \left[ \frac{\text{Acid}}{\text{Base}} \right]$                       D)  $\text{pH} = \text{pKa} + \log \left[ \frac{\text{Base}}{\text{Acid}} \right]$

**Q.10** Which one of the following is the correct presentation for  $K_{\text{sp}}$ ?



A)  $K_{\text{sp}} = \frac{[\text{AgCl}]}{[\text{Ag}^{+1}] [\text{Cl}^{-1}]}$

C)  $K_{\text{sp}} = \frac{[\text{Ag}^{+1}] [\text{Cl}^{-1}]}{[\text{AgCl}]}$

B)  $K_{\text{sp}} = [\text{Ag}^{+1}] [\text{Cl}^{-1}]$

D)  $K_{\text{sp}} = [\text{AgCl}]$

## 2016

**Q.11** Human blood maintains its pH between:

- A) 6.50 - 7.00  
B) 7.20 - 7.25

- C) 7.50 - 7.55  
D) 7.35 - 7.40

**Q.12** Value of  $K_{\text{sp}}$  for  $\text{PbSO}_4$  system at 25 °C is equal to:

- A)  $1.6 \times 10^{-5} \text{ mol}^2\text{dm}^{-6}$   
B)  $1.6 \times 10^{-6} \text{ mol}^2\text{dm}^{-6}$

- C)  $1.6 \times 10^{-8} \text{ mol}^2\text{dm}^{-6}$   
D)  $1.6 \times 10^{-7} \text{ mol}^2\text{dm}^{-6}$

<b>ANSWERS</b>	<b>Q.1</b>	D	<b>Q.7</b>	B
	<b>Q.2</b>	D	<b>Q.8</b>	C
	<b>Q.3</b>	D	<b>Q.9</b>	B
	<b>Q.4</b>	B	<b>Q.10</b>	B
	<b>Q.5</b>	A	<b>Q.11</b>	D
	<b>Q.6</b>	D	<b>Q.12</b>	C

## 9A

## REACTION KINETICS

## 2011

- Q.1** It is experimentally found that a catalyst is used to:
- A) Lower the activation energy  
B) Increase the activation energy  
C) Lower the pH  
D) Decrease the temp of the reaction
- Q.2** According to collision theory of bimolecular reaction in gas phase, the minimum amount of energy required for an effective collision is known as:
- A) Heat of reaction  
B) Rate of reaction  
C) Has no effect on the reaction  
D) Energy of activation

## 2012

- Q.3** In some reactions, a product formed acts as a catalyst. The phenomenon is called
- A) Negative Catalysis  
B) Activation of Catalyst  
C) Heterogeneous catalysis  
D) Autocatalysis
- Q.4** The reaction rate in forward direction decreases with the passage of time because
- A) Concentration of reactants decrease  
B) Concentration of product decreases  
C) The order of reaction changes  
D) Temperature of the system changes

## 2013

- Q.5** By considering Arrhenius equation, the graph between  $\frac{1}{T}$  and 'log K' given a curve of the type:

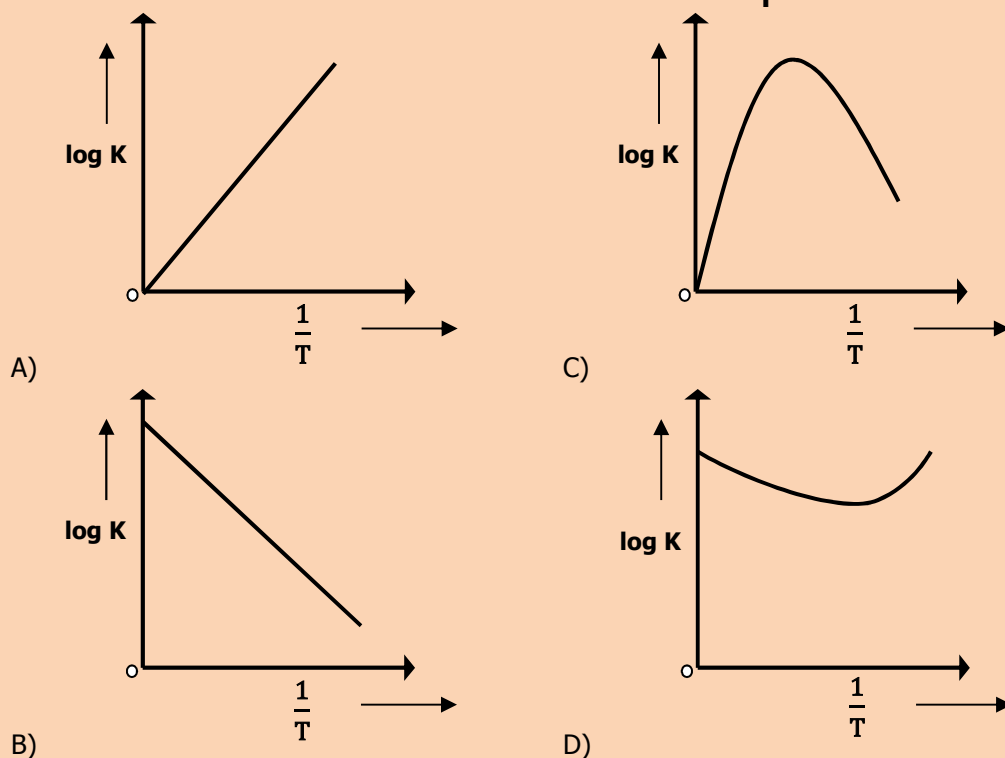

- Q.6 In zero order reactions, the rate is independent of:**
- A) Concentration of the product  
 B) Concentration of the reactant  
 C) Temperature of the reaction  
 D) Surface area of the product

## 2014

- Q.7 If the reactant or product of a chemical reaction can absorb ultraviolet, visible or infrared radiation, then the rate of a chemical reaction can best be measured by which one of the following methods?**
- A) Chemical method  
 B) Spectrometry  
 C) Graphical method  
 D) Differential method
- Q.8 For the reaction  $2\text{NO} + \text{O}_2 \rightleftharpoons 2\text{NO}_2$ , the rate equation for the forward reaction is**
- A) Rate =  $k [\text{NO}] [\text{O}_2]$   
 B) Rate =  $k [\text{NO}]^2 [\text{O}_2]$   
 C) Rate =  $k [\text{NO}_2]^2$   
 D) Rate =  $k [\text{NO}_2]$

## 2015

- Q.9 The half-life of  $\text{N}_2\text{O}_5$  at  $0^\circ\text{C}$  is 24 minutes. How long will it take for sample of  $\text{N}_2\text{O}_5$  to decay to 25% of its original concentration?**
- A) 24 minutes  
 B) 72 minutes  
 C) 120 minutes  
 D) 48 minutes
- Q.10 When the change in concentration is  $6 \times 10^{-4} \text{ mol dm}^{-3}$  and time for that change is 10 seconds, the rate of reaction will be**
- A)  $6 \times 10^{-3} \text{ mol dm}^{-3} \text{ sec}^{-1}$   
 B)  $6 \times 10^{-4} \text{ mol dm}^{-3} \text{ sec}^{-1}$   
 C)  $6 \times 10^{-2} \text{ mol dm}^{-3} \text{ sec}^{-1}$   
 D)  $6 \times 10^{-5} \text{ mol dm}^{-3} \text{ sec}^{-1}$

## 2016

- Q.11  $2\text{A} + \text{B} \longrightarrow \text{Product}$**   
**If the reactant 'B' is in excess, the order of reaction with respect to 'A' in given rate law, Rate =  $k[\text{A}]^2[\text{B}]$  is:**
- A) 2<sup>nd</sup> order reaction  
 B) 1<sup>st</sup> order reaction  
 C) Pseudo 1<sup>st</sup> order reaction  
 D) 3<sup>rd</sup> order reaction
- Q.12 The rate constant 'k' is  $0.693 \text{ min}^{-1}$ . The half-life for the 1<sup>st</sup> order reaction will be:**
- A) 1 min  
 B) 2 min  
 C) 0.693 min  
 D) 4 min

<b>ANSWERS</b>	<b>Q.1</b>	A	<b>Q.7</b>	B
	<b>Q.2</b>	D	<b>Q.8</b>	B
	<b>Q.3</b>	D	<b>Q.9</b>	D
	<b>Q.4</b>	A	<b>Q.10</b>	D
	<b>Q.5</b>	B	<b>Q.11</b>	A
	<b>Q.6</b>	B	<b>Q.12</b>	A



INORGANIC CHEMISTRY

---



## 1B

## PERIODS

## 2011

**Q.1 Carbon exists as allotropes, which are different crystalline or molecular forms of the same substance. Graphite and diamond are allotropes of carbon. Diamond is a non-conductor whereas graphite is a good conductor because:**

- A) Graphite has a layered structure  
 B) In graphite, all valence electrons are tetrahedrally bound  
 C) In graphite one of valence electron is free to move  
 D) Graphite is soft and greasy

**Q.2 The diagram below is a plot of melting points of elements of second period against their atomic numbers. Lithium and fluorine are placed at the extreme ends of the plot, on the basis of melting points where will you place Carbon among the empty slots on the plot?**

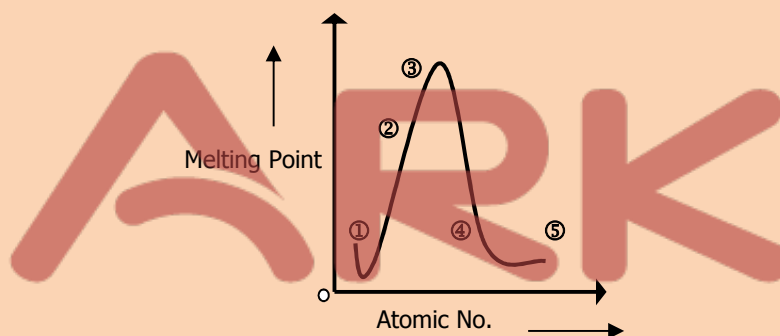

- A) 1  
 B) 2  
 C) 4  
 D) 3

## 2012

**Q.3 Which one remains same along a period?**

- A) Atomic radius  
 B) Melting point  
 C) Number of shells (orbits)  
 D) Electrical conductivity

**Q.4 More the ionization energy of an element:**

- A) More the electropositivity  
 B) More the reducing power  
 C) Less the metallic character  
 D) Bigger the atomic radius

## 2013

**Q.5 What is the trend of melting and boiling point of the elements of short periods as we move from left to right in a periodic table?**

- A) Melting and boiling points first decrease then increase  
 B) Melting and boiling points increase gradually  
 C) Melting and boiling points first increase then decrease  
 D) Melting and boiling points decrease gradually

- Q.6 Along a period, atomic radius decreases. This gradual decrease in radius is due to:**  
 A) Increase in number of electrons in valence shells      C) Decrease in number of shells  
 B) Increase in number of protons in the nucleus      D) Increase in number of shells

## 2014

- Q.7 The trends, in melting points of the elements of 3rd period, are depicted in figure below.**

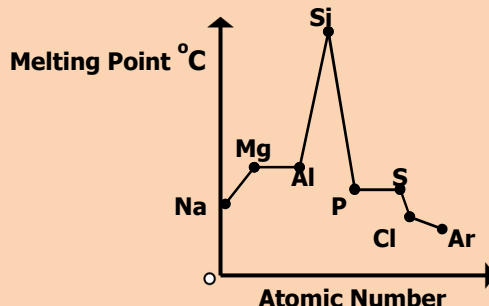

**The sharp decrease observed from 'Si' to 'P' is due to**

- A) Decrease in atomic radius from 'Si' to 'P'      C) Different universities of two elements  
 B) Change in bonding and structure of two elements      D) Increase in electron density from 'Si' to 'P'
- Q.8 Arrange the following elements according to the trend of ionization energies. (C, N, Ne, B)**  
 A) Ne < N < C < B      C) B < C < N < Na  
 B) B < N < C < Na      D) Ne < B < C < N

## 2015

- Q.9 Which one of the following will have the smallest radius?**

- A) Al<sup>3+</sup>      C) Mg<sup>2+</sup>  
 B) Si<sup>4+</sup>      D) Na<sup>+</sup>

- Q.10 Keeping in view the size of atoms, which order is correct?**

- A) N > C      C) Ar > Cl  
 B) P > Si      D) Li > Be

## 2016

- Q.11 Melting points of group II-A elements are higher than those of group I-A because:**

- A) Atoms of II-A elements have smaller size      C) Atoms of II-A elements provide two binding electrons  
 B) II-A elements are more reactive      D) I-A elements have smaller atomic radius

- Q.12 The ionic radius of fluoride ion is:**

- A) 72 pm      C) 136 pm  
 B) 95 pm      D) 157 pm

### ANSWERS

<b>Q.1</b>	C	<b>Q.5</b>	C	<b>Q.9</b>	B
<b>Q.2</b>	D	<b>Q.6</b>	D	<b>Q.10</b>	D
<b>Q.3</b>	C	<b>Q.7</b>	B	<b>Q.11</b>	C
<b>Q.4</b>	C	<b>Q.8</b>	C	<b>Q.12</b>	C

## 2B

## GROUPS

## 2011

- Q.1** When elements of group II-A (alkaline earth metals) are exposed to air, they quickly become coated with a layer of oxide. What is the purpose of this oxide layer?
- A) The oxide layer exposes the metal to Atmospheric attack  
 B) The oxide layer increases the reactivity of metal  
 C) The oxide layer protects the metal from further atmospheric attack  
 D) The oxide layer gives the metal a shiny silvery appearance
- Q.2** In silicon dioxide each silicon atom is tetrahedrally bonded to four oxygen atoms and each oxygen atom is bonded to two silicon atoms. The ratio of silicon to oxygen atoms is:
- A) 2:2  
 B) 1:2  
 C) 2:1  
 D) 1:4

## 2012

- Q.3** Alkaline earth metal hydroxides decompose on heating. Which of the following reactions is a correct representation of this decomposition?
- A)  $M(OH)_{2(s)} \longrightarrow MO_{(s)} + H_2O_{(l)}$   
 B)  $MOH_{(s)} \longrightarrow M_2O_{(s)} + H_2O_{(l)}$   
 C)  $2MOH_{2(s)} \longrightarrow 2MO_{(s)} + H_{2(l)}$   
 D)  $4MOH_{(s)} \longrightarrow 4M_{(s)} + 2H_2O_{(l)} + O_2$
- Q.4** Carbon has the unique ability to form long chains by bonding with other carbon atoms. This property of self-linking in carbon is known as:
- A) Condensation  
 B) Polymerization  
 C) Cyclization  
 D) Catenation

## 2013

- Q.5** Alkaline earth metal oxides react with water to give hydroxides. The solubility of alkaline earth metal oxides in water increases as we move from top to bottom in a group. Which of the following alkaline earth metal oxides is least soluble in water?
- A) MgO  
 B) CaO  
 C) BaO  
 D) SrO
- Q.6** The electronic structure of carbon monoxide is represented as:
- A)  $:\text{C} \equiv \text{O}:$   
 B)  $:\text{C} \equiv \ddot{\text{O}}:$   
 C)  $\text{C} \equiv \ddot{\text{O}}:$   
 D)  $\dot{\text{C}} \equiv \ddot{\text{O}}$

## 2014

- Q.7** Radon is \_\_\_\_\_ emitter and being radioactive is used in \_\_\_\_\_ treatment in radiotherapy:
- A)  $\beta$ , cancer  
 B)  $\alpha$ , cancer  
 C)  $\alpha$ , kidney stone  
 D)  $\beta$ , kidney stone

- Q.8** Which one of the following noble gases is used for providing an inert atmosphere for welding?  
 A) Helium  
 B) Neon  
 C) Argon  
 D) Krypton

## 2015

- Q.9** On the basis of oxidizing power of halogens, which reaction is possible?  
 A)  $I_2 + 2Cl^- \longrightarrow Cl_2 + 2I^-$   
 B)  $Br_2 + 2I^- \longrightarrow I_2 + 2Br^-$   
 C)  $Cl_2 + 2F^- \longrightarrow F_2 + 2Cl^-$   
 D)  $I_2 + 2Br^- \longrightarrow Br_2 + 2I^-$

- Q.10** Which one of the following gases is used as mixture for breathing by sea divers?  
 A) Oxygen and Nitrogen  
 B) Nitrogen and Helium  
 C) Helium and Oxygen  
 D) Helium and Hydrogen

## 2016

- Q.11**  $2NaOH_{(aq)} + Cl_{2(g)} \longrightarrow NaCl + NaClO + H_2O$  proceed at:  
 A) 500 °C  
 B) 200 °C  
 C) -10 °C  
 D) 15 °C

- Q.12** Which halogen molecule 'X<sub>2</sub>' has lowest dissociation energy?  
 A) Cl<sub>2</sub>  
 B) Br<sub>2</sub>  
 C) I<sub>2</sub>  
 D) F<sub>2</sub>

<b>ANSWERS</b>	Q.1	C	Q.7	B
	Q.2	B	Q.8	A
	Q.3	A	Q.9	B
	Q.4	D	Q.10	C
	Q.5	A	Q.11	D
	Q.6	A	Q.12	D

## 3B

## TRANSITION ELEMENTS

## 2011

**Q.1 Hydrogenation of unsaturated oils is done by using:**

- A) Finally divided nickel  
 B) Finally divided iron  
 C) Vanadium pentaoxide  
 D) Copper

**Q.2 Pick the correct statement:**

- A) Chelates are usually more stable than ordinary complexes  
 B) Ordinary complexes are more stable than chelates  
 C) Monodentate ligands form the chelates  
 D) Chelates have no ring structures

## 2012

**Q.3 Oxidation state of 'Mn' in  $\text{KMnO}_4$ ,  $\text{K}_2\text{MnO}_4$ ,  $\text{MnO}_2$  and  $\text{MnSO}_4$  is in the order:**

- A) +7, +6, +2, +4  
 B) +6, +7, +2, +4  
 C) +7, +6, +4, +2  
 D) +4, +6, +7, +2

**Q.4 Which pair of transition elements shows abnormal electronic configuration?**

- A) Sc and Zn  
 B) Cu and Sc  
 C) Zn and Cu  
 D) Cu and Cr

## 2013

**Q.5 Which one pair has the same oxidation state of 'Fe'?**

- A)  $\text{FeSO}_4$  and  $\text{FeCl}_3$   
 B)  $\text{FeCl}_2$  and  $\text{FeCl}_3$   
 C)  $\text{FeSO}_4$  and  $\text{FeCl}_2$   
 D)  $\text{Fe}_2(\text{SO}_4)_3$  and  $\text{FeSO}_4$

**Q.6 Oxidation state of 'Fe' in  $\text{K}_3[\text{Fe}(\text{CN})_6]$  is:**

- A) +2  
 B) +3  
 C) -6  
 D) -3

## 2014

**Q.7 Electronic configuration of Manganese (Mn) is**

- A) Mn (Ar)  $\begin{array}{c} \text{3d} \\ \uparrow \uparrow \uparrow \uparrow \uparrow \\ \text{3d} \end{array} \begin{array}{c} \text{4s} \\ \uparrow \downarrow \\ \text{4s} \end{array}$       C) Mn (Ar)  $\begin{array}{c} \text{3d} \\ \uparrow \downarrow \uparrow \downarrow \uparrow \uparrow \\ \text{3d} \end{array} \begin{array}{c} \text{4s} \\ \uparrow \downarrow \\ \text{4s} \end{array}$
- B) Mn (Ar)  $\begin{array}{c} \uparrow \downarrow \uparrow \downarrow \uparrow \downarrow \uparrow \downarrow \\ \text{3d} \end{array} \begin{array}{c} \uparrow \\ \text{4s} \end{array}$       D) Mn (Ar)  $\begin{array}{c} \uparrow \downarrow \uparrow \downarrow \uparrow \downarrow \uparrow \uparrow \\ \text{3d} \end{array} \begin{array}{c} \uparrow \\ \text{4s} \end{array}$

**Q.8 The percentage of carbon in different types of iron products is in the order of**

- A) Cast Iron > Wrought Iron > Steel  
 B) Wrought Iron > Steel > Cast Iron  
 C) Cast Iron > Steel > Wrought Iron  
 D) Cast Iron > Steel > Wrought Iron

## 2015

- Q.9**  $[\text{Ti}(\text{H}_2\text{O})_6]^{+3}$  transmits  
 A) Yellow and Red light  
 B) Yellow and Blue light  
 C) Red and white light  
 D) Red and blue light
- Q.10** Electronic configuration of Gold [Au79] is  
 A)  $[\text{Xe}] 4f^{14}, 5d^{10}, 6s^1$   
 B)  $[\text{Xe}] 4f^{10}, 5d^{10}, 6s^2$   
 C)  $[\text{Xe}] 4f^{14}, 5d^9, 6s^2$   
 D)  $[\text{Xe}] 4f^{14}, 5d^{10}, 6s^2$

## 2016

- Q.11** The anomalous electronic configuration shown by chromium and copper among 3-d series of elements is due to:  
 A) Colour of ions of these metals  
 B) Variable oxidation states of metals  
 C) Stability associated with this configuration  
 D) Complex formation tendency of metals
- Q.12** Which element of 3d series of periodic table shows the electronic configuration of  $3d^6, 4s^2$ ?  
 A) Copper  
 B) Cobalt  
 C) Zinc  
 D) Nickel

<b>ANSWERS</b>	<b>Q.1</b>	A	<b>Q.7</b>	A
	<b>Q.2</b>	A	<b>Q.8</b>	C
	<b>Q.3</b>	C	<b>Q.9</b>	D
	<b>Q.4</b>	D	<b>Q.10</b>	A
	<b>Q.5</b>	C	<b>Q.11</b>	C
	<b>Q.6</b>	A	<b>Q.12</b>	D

## 4B

# ELEMENTS OF BIOLOGICAL IMPORTANCE

## 2011

- Q.1 In contact process, the catalyst used for the conversion of Sulphur dioxide to Sulphur trioxide is:**
- A) Magnesium oxide  
B) Aluminum oxide  
C) Silicon dioxide  
D) Vanadium pentoxide
- Q.2 The unpolluted natural rain water is slightly acidic due to the reaction of rain water with:**
- A) Sulphur dioxide  
B) Oxides of nitrogen  
C) Carbon dioxide  
D) Hydrogen present in air
- Q.3 In the Haber's process for the manufacturing of ammonia, nitrogen is taken from:**
- A) Proteins occurring in living bodies  
B) Ammonium salts obtained industrially  
C) Air  
D) Mineral containing nitrates
- Q.4 In comparison with oxygen gas, a strong triple bond is present between two nitrogen atoms in a molecule and therefore nitrogen gas is:**
- A) Highly reactive gas  
B) Completely inert like noble gases  
C) Very less reactive gas  
D) Moderately reactive gas

## 2012

- Q.5 The acid rain water has pH:**
- A) Below 5  
B) 7  
C) Between 5 and 7  
D) Between 7 and 14
- Q.6 In Contact Process for manufacturing sulphuric acid, Sulphur trioxide (SO<sub>3</sub>) is not absorbed in water because**
- A) The reaction does not go to completion  
B) The reaction is highly exothermic  
C) The reaction is quite slow  
D) SO<sub>3</sub> is insoluble in water
- Q.7 In modern Haber Process Plants, the temperature maintained during the process is**
- A) 670 – 770 K (400 °C – 500 °C)  
B) 270 – 370 K (0 °C – 100 °C)  
C) 370 – 470 K (100 °C – 200 °C)  
D) 570 – 600 K (300 °C – 380 °C)
- Q.8 In the Haber process for manufacturing of ammonia, Nitrogen is taken from**
- A) Proteins occurring in living bodies  
B) Ammonium salts obtained industrially  
C) Air  
D) Minerals containing nitrates

## 2013

- Q.9 The nature of an aqueous solution of ammonia (NH<sub>3</sub>) is:**
- A) Amphoteric  
B) Neutral  
C) Acidic  
D) Basic

- Q.10** Unpolluted rain water has a pH of:  
 A) 4.9  
 B) 5.6  
 C) 5.3  
 D) 7.0
- Q.11** In comparison with oxygen gas, a strong triple bond is present between two nitrogen atoms in a molecule and therefore nitrogen gas is:  
 A) Highly reactive gas  
 B) Completely inert like noble gases  
 C) Moderately reactive gas  
 D) Very less reactive gas
- Q.12** The catalyst used in the Haber's process is:  
 A) Magnesium oxide  
 B) Aluminium oxide  
 C) Silicon oxide  
 D) Iron crystals with metal oxide promoters

## 2014

- Q.13** Which one of the following is correct equation of 1<sup>st</sup> ionization of sulphuric acid?  
 A)  $\text{H}_2\text{SO}_4(\text{aq}) + \text{H}_2\text{O}(\text{l}) \longrightarrow 2\text{H}^+ + \text{SO}_4^{2-}$   
 B)  $\text{H}_2\text{SO}_4(\text{aq}) + \text{H}_2\text{O}(\text{l}) \longrightarrow \text{H}^+(\text{aq}) + \text{HSO}_4^-$   
 C)  $\text{H}_2\text{SO}_4(\text{aq}) + \text{H}_2\text{O}(\text{l}) \longrightarrow 2\text{H}^+ + \text{SO}_4^{2-}$   
 D)  $\text{H}_2\text{SO}_4(\text{aq}) + \text{H}_2\text{O}(\text{l}) \longrightarrow \text{H}_3\text{O}^+ + \text{SO}_4^{2-}$
- Q.14** Which one of the following is the correct chemical reaction for Ammonia formation by Haber process?  
 A)  $\text{N}_2(\text{g}) + 3\text{H}_2(\text{g}) \longrightarrow 2\text{NH}_3(\text{g})$   
 B)  $2\text{N}(\text{g}) + 3\text{H}_2(\text{g}) \rightleftharpoons \text{NH}_3(\text{g})$   
 C)  $2\text{N}(\text{g}) + 3\text{H}_2(\text{g}) \longrightarrow 2\text{NH}_3(\text{g})$   
 D)  $\text{N}_2(\text{g}) + 3\text{H}_2(\text{g}) \rightleftharpoons 2\text{NH}_3(\text{g})$
- Q.15** The pH of acid rain is  
 A) 7  
 B) Between 5 and 7  
 C) Below 5  
 D) Between 7 and 14
- Q.16** Which one of the following products is obtained when sulphur trioxide is absorbed in concentrated sulphuric acid?  
 A) Oleum  
 B) Aqua Regia  
 C) Hydrogen sulphide  
 D) Sulphate ion

## 2015

- Q.17** About 80% of ammonia is used for the production of  
 A) Explosives  
 B) Fertilizers  
 C) Nylon  
 D) Polymers
- Q.18** Urea is the most widely used nitrogen fertilizer in Pakistan. Its composition is  
 A)  $\text{NH}_2\text{CO}$   
 B)  $\text{N}_2\text{H}_5\text{CO}_2$   
 C)  $\text{N}_2\text{H}_4\text{CO}_2$   
 D)  $\text{N}_2\text{H}_4\text{CO}$
- Q.19** During the manufacture of nitric acid, nitric oxide is oxidized to nitrogen dioxide. This reaction is given as:



According to Le Chatelier's Principle

- A) Reaction must not be temperature dependent  
 B) Reaction must be carried out at room temperature  
 C) Reaction must be carried out at low temperature  
 D) Reaction must be carried out at high temperature
- Q.20** What is the percentage of nitrogen in  $\text{NH}_3\text{NO}_3$ ?  
 A) 65%  
 B) 35%  
 C) 20%  
 D) 58%



## 2016

**Q.21** The %age of nitrogen in ammonium nitrate is:

- A) 46% C) 33%  
B) 82% D) 13%

**Q.22** Which one of the following is anhydride of sulphuric acid?

- A) Sulphur (II) oxide C) Iron pyrite  
B) Sulphur (VI) oxide D) Sulphur (VI) oxide

**Q.23** During contact process of  $\text{H}_2\text{SO}_4$  synthesis, the following reaction occurs:

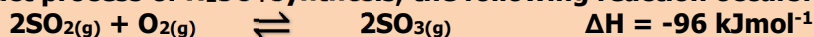

Which step is used to increase the yield of  $\text{SO}_3$ ?

- A) Temperature is raised to very high degree C) Both temperature and pressure are kept very low  
B)  $\text{SO}_3$  formed is removed very quickly D) An excess of air is used to drive the equilibrium to the right side

**Q.24** Synthesis of ammonia by Haber's process is a reversible reaction. What should be done to increase the yield of ammonia in the following reaction?

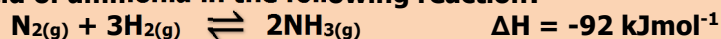

- A) Pressure should be decreased C) Pressure should be increased  
B) Ammonia should remain in reaction mixture D) Concentration of nitrogen should be decreased

<b>ANSWERS</b>	<b>Q.1</b>	D	<b>Q.7</b>	A	<b>Q.13</b>	B	<b>Q.19</b>	C
	<b>Q.2</b>	A	<b>Q.8</b>	C	<b>Q.14</b>	D	<b>Q.20</b>	B
	<b>Q.3</b>	C	<b>Q.9</b>	A	<b>Q.15</b>	C	<b>Q.21</b>	C
	<b>Q.4</b>	B	<b>Q.10</b>	B	<b>Q.16</b>	A	<b>Q.22</b>	D
	<b>Q.5</b>	A	<b>Q.11</b>	D	<b>Q.17</b>	B	<b>Q.23</b>	D
	<b>Q.6</b>	B	<b>Q.12</b>	D	<b>Q.18</b>	D	<b>Q.24</b>	C



ARK  
ORGANIC CHEMISTRY

---

## 1C

## FUNDAMENTAL PRINCIPLES

## 2011

- Q.1** The compound with an atom, which has unshared pair of electrons is called:  
 A) Nucleophile  
 B) Electrophile  
 C) Protophile  
 D) None of the above
- Q.2** 1-chloropropane and 2-chloropropane are isomers of each other, the type of isomerism in these two is called:  
 A) Cis-trans isomerism  
 B) Chain isomerism  
 C) Position isomerism  
 D) Functional group isomerism

## 2012

- Q.3** Ethene on polymerization, gives the product polyethene. This reaction may be called as  
 A) Addition  
 B) Condensation  
 C) Substitution  
 D) Pyrolysis
- Q.4** In the following, which one is free radical?  
 A)  $\text{Cl}^-$   
 B)  $\text{Cl}^+$   
 C)  $\text{Cl}_2$   
 D)  $\text{Cl}^\bullet$

## 2013

- Q.5** The cis-isomerism is shown by:

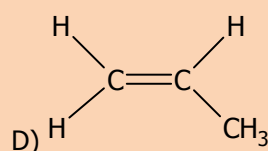
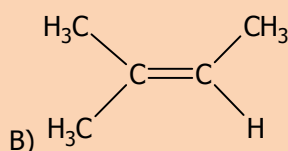
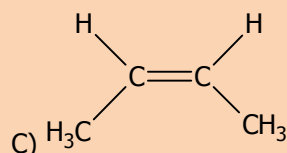
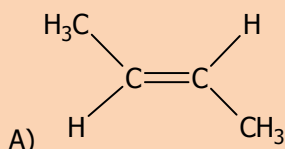

- Q.6** Select the nucleophile from the following examples:  
 A)  $\text{NO}_2$   
 B)  $\text{NH}_3$   
 C)  $\text{NO}_2^+$   
 D)  $\text{N}^+\text{H}_4$

## 2014

- Q.7** Which one of the following compound is a ketone?  
 A)  $\text{CH}_3 - \text{O} - \text{CH}_2 - \text{CH}_3$   
 B)  $\text{CH}_3 - \text{CO} - \text{CH}_2 - \text{CH}_3$   
 C)  $\text{CH}_3\text{COCO}(\text{OH})$   
 D)  $\text{CH}_3 - \text{CH}_2\text{CHO}$



<b>ANSWERS</b>	<b>Q.1</b>	A	<b>Q.7</b>	B
	<b>Q.2</b>	C	<b>Q.8</b>	A
	<b>Q.3</b>	A	<b>Q.9</b>	A
	<b>Q.4</b>	D	<b>Q.10</b>	C
	<b>Q.5</b>	C	<b>Q.11</b>	B
	<b>Q.6</b>	B	<b>Q.12</b>	C



## 2C

## HYDROCARBONS

## 2011

**Q.1 Benzene in the presence of  $\text{AlCl}_3$  produces acetophenone when reacts with:**

- A) Acetyl chloride  
 B) Acetic acid  
 C) Ethyl benzene  
 D) Ethanoic acid

**Q.2 The substitution of a '-H' by '-NO<sub>2</sub>' group in benzene is called:**

- A) Nitration  
 B) Ammunolusis  
 C) Sulphonation  
 D) Reduction of benzene

## 2012

**Q.3 The introduction of  $\text{R}-\overset{\text{O}}{\parallel}{\text{C}}^+$  group in benzene is called**

- A) Acylation  
 B) Carbonyl reduction  
 C) Alkylation  
 D) Formylation

**Q.4 In the reaction of ethane with bromine the intermediate formed is**

- A)  $\begin{array}{c} \text{H}_2\text{C} \quad \text{CH}_2 \\ \diagdown \quad / \\ \text{Br}^+ \end{array}$   
 B)  $\begin{array}{c} \text{H}_2\text{C} \quad \text{CH}_2 \\ | \\ \text{Br} \end{array}$   
 C)  $\begin{array}{c} \text{H}_2\text{C} \quad \text{CH}_2^+ \\ | \\ \text{Br} \end{array}$   
 D)  $\text{H}_2\text{C}=\text{CHBr}$

## 2013

**Q.5 The introduction of an alkyl group in benzene takes place in the presence of  $\text{AlCl}_3$  and:**

- A)  $\text{R}-\overset{\text{O}}{\parallel}{\text{C}}-\text{OH}$   
 B)  $\text{R}-\text{Cl}$   
 C)  $\text{R}-\overset{\text{O}}{\parallel}{\text{C}}-\text{Cl}$   
 D)  $\text{R}-\overset{\text{O}}{\parallel}{\text{C}}-\text{O}^-$

**Q.6 What is the product formed when propene reacts with  $\text{HBr}$ ?**

- A)  $\text{H}_3\text{C}-\text{CH}_2-\text{CH}_2\text{Br}$   
 B)  $\text{BrH}_2\text{C}-\text{CH}=\text{CH}_2\text{Br}$   
 C)  $\begin{array}{c} \text{H}_2\text{C} \quad \text{CH} \quad \text{CH}_3 \\ | \quad | \\ \text{Br} \quad \text{Br} \end{array}$   
 D)  $\begin{array}{c} \text{H}_3\text{C} \quad \text{CH} \quad \text{CH}_3 \\ | \\ \text{Br} \end{array}$

## 2014

**Q.7 Addition of unsymmetrical reagent to an unsymmetrical alkene is governed by:**

- A) Cannizzaro's Reaction  
 B) Kirchhoff Rule  
 C) Aldol Condensation  
 D) Markownikov's Rule

**Q.8 Ethylene glycols are used as**

- A) Anesthetic  
 B) Knocking agent  
 C) Freezing agent  
 D) Anti-freezing agent

## 2015

**Q.9 Order of reactivity of alkenes with hydrogen halide is:**

- A) HBr > HI > HCl  
 B) HI > HBr > HF  
 C) HF > HI > HCl  
 D) HI > HBr > HCl

**Q.10 The given three hydrocarbons are**

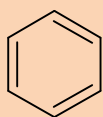

**Benzene**

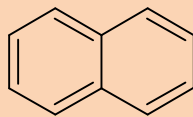

**Naphthalene**

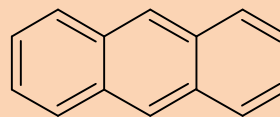

**Anthracene**

- A) Alicyclic hydrocarbons  
 B) Aromatic hydrocarbons  
 C) Acyclic Hydrocarbons  
 D) Heterocyclic hydrocarbons

## 2016

**Q.11 Which one of the following reactions shows combustion of a saturated hydrocarbon?**

- A)  $C_2H_4 + 3O_2 \longrightarrow 2CO_2 + 2H_2O$   
 B)  $CH_4 + 2O_2 \longrightarrow CO_2 + 2H_2O$   
 C)  $CH_4 + \frac{1}{2} O_2 \xrightarrow[400^\circ C, 200 \text{ atm}]{Cu} CH_3OH$   
 D)  $C_2H_2 + \frac{5}{2} O_2 \longrightarrow 2CO_2 + H_2O$

**Q.12 The average bond energy of C-Br is:**

- A) 228 kJmol<sup>-1</sup>  
 B) 200 kJmol<sup>-1</sup>  
 C) 250 kJmol<sup>-1</sup>  
 D) 290 kJmol<sup>-1</sup>

<b>ANSWERS</b>	<b>Q.1</b>	A	<b>Q.7</b>	D
	<b>Q.2</b>	A	<b>Q.8</b>	D
	<b>Q.3</b>	A	<b>Q.9</b>	D
	<b>Q.4</b>	A	<b>Q.10</b>	B
	<b>Q.5</b>	B	<b>Q.11</b>	B
	<b>Q.6</b>	D	<b>Q.12</b>	D

## 3C

## ALKYL HALIDES

## 2011

- Q.1** When purely alcoholic solution of sodium/potassium hydroxide and halogenoalkanes are reacted an alkene is formed, what is the mechanism of reaction?
- A) Elimination  
B) Dehydration  
C) Debromination  
D) Reduction of benzene
- Q.2** The organic compound carbon tetrachloride is used as:
- A) Lubricant  
B) Solvent  
C) Oxidant  
D) Plastic

## 2012

- Q.3** The alkaline hydrolysis of bromoethane shown below gives alcohol as the product:



The reagent and the condition used in this reaction may be:

- A)  $\text{H}_2\text{O}$  at room temperature  
B) Ethanol, heat  
C)  $\text{KOH}$  in alcohol  
D) Dilute  $\text{NaOH}_{(\text{aq})}$  warm
- Q.4** In substitution reactions, dihaloalkane or secondary halogenoalkane give / show:
- A)  $\text{S}_{\text{N}}1$  Mechanism  
B)  $\text{S}_{\text{N}}2$  Mechanism  
C) Both  $\text{E}_1$  and  $\text{E}_2$   
D) Both  $\text{S}_{\text{N}}1$  and  $\text{S}_{\text{N}}2$

## 2013

- Q.5** The order of reactivity of alkyl halides towards nucleophile is:
- A)  $\text{RI} > \text{RBr} > \text{RF} > \text{RCl}$   
B)  $\text{RI} > \text{RBr} > \text{RCl} > \text{RF}$   
C)  $\text{RF} > \text{RCl} > \text{RBr} > \text{RI}$   
D)  $\text{RF} > \text{RBr} > \text{RCl} > \text{RI}$
- Q.6** Consider the reaction given below:
- $$\text{H}_3\text{C}-\text{CH}_2-\text{CH}_2-\text{CH}_2\text{Br} \begin{cases} \longrightarrow \text{H}_3\text{C}-\text{CH}_2-\text{CH}_2-\text{CH}_2\text{OH} \\ \longrightarrow \text{H}_3\text{C}-\text{CH}_2-\text{CH}=\text{CH}_2 \end{cases}$$

Which statement is true?

- A) Reagent for I is  $\text{KOH}$  in alcohol  
B) Reagent for II is  $\text{KOH}$  in aqueous medium  
C) Reaction I is Debromination  
D) Reaction II is elimination

## 2014

- Q.7** The halothane used in hospitals as an anesthetic is chemically
- A) 1-Bromo-1-chloro-2, 2, 2-trifluoroethane  
B) 2-Bromo-2-chloro-1, 1, 1-trifluoroethane  
C) 1, 1, 1-Trifluoro-2-bromo-2-chloroethane  
D) 2-Chloro-2-bromo-1, 1, 1-trifluoroethane



**Q.8** If halogenoalkanes are mixed with an excess of ethanoic ammonia and heated under pressure, amine are formed. Which amine is formed in the following reaction?

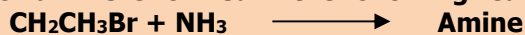

- A)  $\text{CH}_3\text{—CH}_2\text{—NH—CH}_2\text{—CH}_3$       C)  $\text{CH}_3\text{—CH}_2\text{—CH}_2\text{—NH}_2$   
 B)  $\text{CH}_3\text{—CH}_2\text{—NH}_2$       D)  $\text{H}_2\text{N—CH}_2\text{—CH}_2\text{—NH}_2$

## 2015

**Q.9** The IUPAC name of the given compound is

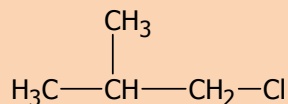

- A) 1-Chloro-2-methylpropane      C) Isobutyl chloride  
 B) 1-Chloro-2-methylbutane      D) 2-Methyl-3-chloropropane

**Q.10** In the below reaction, the configuration of product is

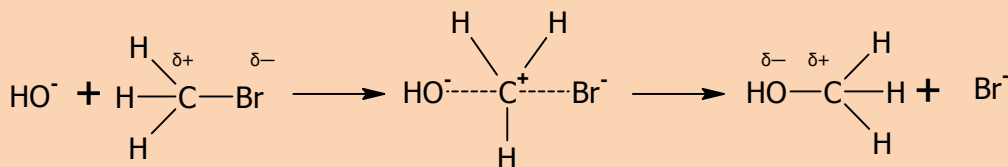

- A) 100% same of the configuration of reactant      C) 50% inverted  
 B) 50% retained      D) 100% opposite from configuration of reactant

## 2016

**Q.11** Consider the reaction given below:



Mechanism followed by the reaction is:

- A) E2      C) S<sub>N</sub>1  
 B) E1      D) S<sub>N</sub>2

**Q.12** Which one of the following is NOT a nucleophile:

- A)  $\text{NH}_2^-$       C)  $\text{BF}_3$   
 B)  $\text{H}_2\text{O}$       D)  $\text{CH}_3^-$

<b>ANSWERS</b>	<b>Q.1</b>	A	<b>Q.7</b>	B
	<b>Q.2</b>	B	<b>Q.8</b>	B
	<b>Q.3</b>	D	<b>Q.9</b>	A
	<b>Q.4</b>	D	<b>Q.10</b>	D
	<b>Q.5</b>	B	<b>Q.11</b>	A
	<b>Q.6</b>	D	<b>Q.12</b>	C

## 4C

## ALCOHOLS AND PHENOLS

## 2011

- Q.1** An alcohol is converted to an aldehyde with same number of carbon atoms as that of alcohol in the presence of  $K_2Cr_2O_7/H_2SO_4$  the alcohol is:
- A)  $CH_3Cl(CH_2)_2OH$   
 B)  $CH_3CH_2CH_2OH$   
 C)  $(CH_3)_3COH$   
 D)  $(CH_3)_3CHOH$
- Q.2** Which of the following is a secondary alcohol?
- A)  $\begin{array}{c} H_3C-CH-OH \\ | \\ CH_3 \end{array}$   
 B)  $H_3C-CH_2-CH_2-OH$   
 C)  $\begin{array}{c} H_3C-CH-CH_2-OH \\ | \\ CH_3 \end{array}$   
 D)  $\begin{array}{c} H_3C-CH-CH_2-C-CH_3 \\ | \quad \quad | \\ CH_3 \quad \quad OH \end{array}$
- Q.3** Which enzyme is involved in the fermentation of glucose:
- A) Zymase  
 B) Invertase  
 C) Urease  
 D) Diastase
- Q.4** Relative acidic strength of alcohol, phenol, water and carboxylic acid is:
- A) Carboxylic acid > Alcohol > Phenol > Water  
 B) Carboxylic acid > Phenol > Water > Alcohol  
 C) Phenol > Carboxylic acid > Alcohol > Water  
 D) Water > Alcohol > Phenol > Carboxylic acid

## 2012

- Q.5** The dehydration of ethyl alcohol with concentrated  $H_2SO_4$  at  $140^\circ C$  gives:
- A) Ethene  
 B) Diethyl ether  
 C) Alcohol  
 D) Carboxylic acid
- Q.6** Ethanol can be converted in to ethanoic acid by:
- A) Oxidation  
 B) Fermentation  
 C) Hydration  
 D) Hydrogenation
- Q.7** The following structure is of:
- $$\begin{array}{c} R \\ | \\ R-C-OH \\ | \\ R \end{array}$$
- A) Secondary alcohol  
 B) Primary alcohol  
 C) Tertiary alcohol  
 D) Carboxylic acid
- Q.8** When ethanol is warmed with ethanoic acid in the presence of strong acid catalyst, an ester ethyl ethanoate is formed.
- $$CH_3CH_2OH + CH_3CO_2H \longrightarrow CH_3CO_2CH_2CH_3$$
- During this reaction:
- A) Alcohol is reduced  
 B) O-H bond in ethanoic acid is broken  
 C) O-H bond in ethanol is broken  
 D) Acid is oxidized

## 2013

**Q.9 Consider the following reaction:**



**What product(s) may be formed?**

- A)  $\text{C}_2\text{H}_5\text{Cl}$  only  
 B)  $\text{C}_2\text{H}_5\text{Cl}$  and  $\text{HCl}$   
 C)  $\text{C}_2\text{H}_5\text{Cl}$ ,  $\text{POCl}_3$  and  $\text{HCl}$   
 D)  $\text{C}_2\text{H}_5\text{Cl}$  and  $\text{POCl}_3$

**Q.10**

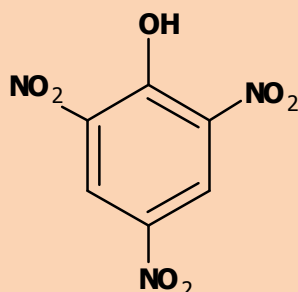

is named as:

- A) Picric acid  
 B) Nitro phenol  
 C) Benzoic acid  
 D) Malonic acid

**Q.11 Aqueous phenol decolorizes bromine water to form a white precipitate. What is the structure of the white precipitate formed?**

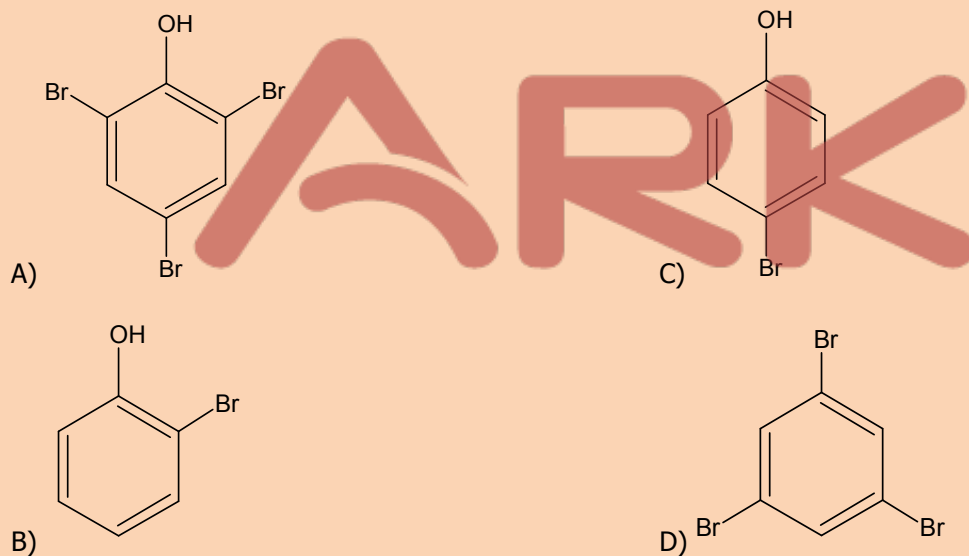

**Q.12 The relative strength of carboxylic acid, water, ethanol and phenol has the following order of increasing acid strength:**

- A) Carboxylic Acid > Phenol > Ethanol > Water  
 B) Carboxylic Acid > Phenol > Water > Ethanol  
 C) Phenol > Carboxylic Acid > Ethanol > Water  
 D) Water > Ethanol > Phenol > Carboxylic Acid

## 2014

**Q.13 Primary, secondary and tertiary alcohols can be identified and distinguished by**

- A) Lucas test  
 B) Iodoform test  
 C) Baeyer's test  
 D) Silver mirror test

**Q.14 Which one of the following alcohol is indicated by formation of yellow crystals in Iodoform test?**

- A) Methanol  
 B) Ethanol  
 C) Butanol  
 D) Propanol

**Q.15 The formula of 2, 4, 6-tribromo phenol is**

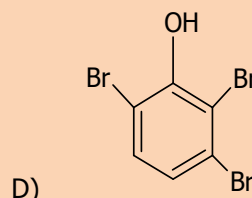
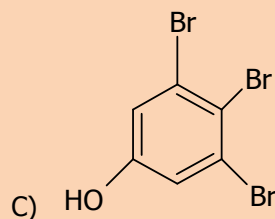
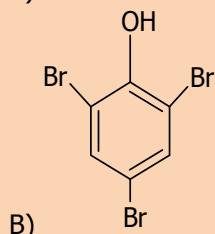
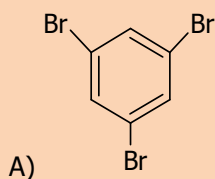

**Q.16 Which one of the following groups is indicated when HCl is formed by reaction of ethanol with phosphorous pentachloride?**

- A) Amino group  
B) Hydroxyl group

- C) Halide group  
D) Hydride group

## 2015

**Q.17 Which one of the following was used as one of the earliest antiseptic and disinfectant?**

- A) Phenol  
B) Ether

- C) Ethanol  
D) Methanol

**Q.18 Which one of the following is NOT able to denature the ethanol?**

- A) Methanol  
B) Lactic acid

- C) Pyridine  
D) Acetone

**Q.19 How will you distinguish between methanol and ethanol?**

- A) By Lucas test  
B) By silver mirror test

- C) By oxidation  
D) By Iodoform test

**Q.20 To produce absolute alcohol (100%) from rectified spirit (95.6% alcohol), the remaining 4.4% water must be removed by a drying agent such as**

- A) Calcium oxide  
B) Calcium chloride

- C) Calcium carbonate  
D) Carbon monoxide

## 2016

**Q.21 Which one of the following is an appropriate indication of positive iodoform test?**

- A) Formation of H<sub>2</sub>O  
B) Release of H<sub>2</sub> gas

- C) Brick red precipitate  
D) Yellow crystal

**Q.22**

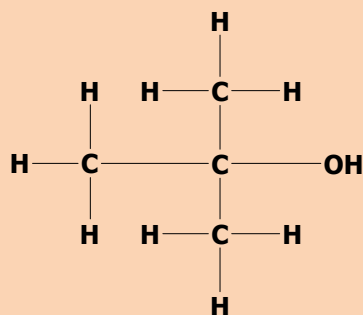

**Which one of the following is the proper classification of above formula:**

- A) Primary  
B) Secondary

- C) Tertiary  
D) Polyhydride

**Q.23** Which one of the following is an appropriate structure of product of bromination?

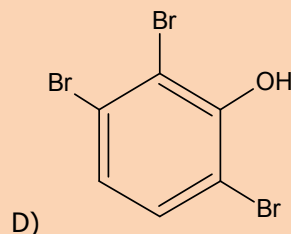
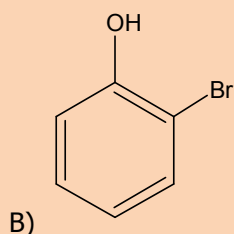
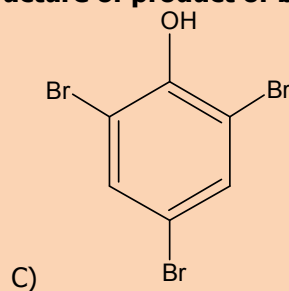
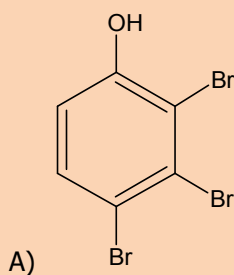

**Q.24**

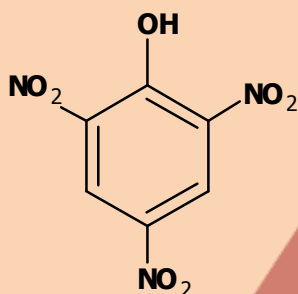

Which one of the following is an appropriate name of above compound?

- A) 1,3,6-Trinitrophenol  
B) m-Nitrophenol

- C) Tartaric acid  
D) Picric acid

<b>ANSWERS</b>	<b>Q.1</b>	B	<b>Q.7</b>	A	<b>Q.13</b>	A	<b>Q.19</b>	D
	<b>Q.2</b>	A	<b>Q.8</b>	C	<b>Q.14</b>	B	<b>Q.20</b>	A
	<b>Q.3</b>	A	<b>Q.9</b>	B	<b>Q.15</b>	B	<b>Q.21</b>	D
	<b>Q.4</b>	B	<b>Q.10</b>	A	<b>Q.16</b>	B	<b>Q.22</b>	C
	<b>Q.5</b>	B	<b>Q.11</b>	A	<b>Q.17</b>	A	<b>Q.23</b>	C
	<b>Q.6</b>	A	<b>Q.12</b>	B	<b>Q.18</b>	B	<b>Q.24</b>	D

## 5C

## ALDEHYDES AND KETONES

2011

Q.1 Consider the following reaction:



This reaction represents one of the following tests.

- A) Fehling test  
 B) Benedict test  
 C) Ninhydrin test  
 D) Tollens test

Q.2 In the below reaction, the nucleophile is:



- A) CN<sup>-</sup>  
 B) HCl  
 C) Cl  
 D) OH

Q.3 Which one of the following compound belongs to the homologous series of aldehydes?

- A)  $\begin{array}{c} \text{O} \\ || \\ \text{H}-\text{C}-\text{Cl} \end{array}$   
 B)  $\begin{array}{c} \text{O} \\ || \\ \text{H}-\text{C}-\text{NH}_2 \end{array}$   
 C)  $\begin{array}{c} \text{O} \\ || \\ \text{H}-\text{C}-\text{H} \end{array}$   
 D)  $\begin{array}{c} \text{O} \\ || \\ \text{H}-\text{C}-\text{OC}_2\text{H}_5 \end{array}$

2012

Q.4 Formaldehyde reacts with HCN (NaCN + HCl) to give a compound:

- A)  $\begin{array}{c} \text{H}_3\text{C} \quad \text{OH} \\ \diagdown \quad / \\ \text{C} \\ / \quad \diagdown \\ \text{H} \quad \text{CN} \end{array}$   
 B)  $\begin{array}{c} \text{H} \quad \text{OH} \\ \diagdown \quad / \\ \text{C} \\ / \quad \diagdown \\ \text{H} \quad \text{CN} \end{array}$   
 C)  $\begin{array}{c} \text{H}_3\text{C} \quad \text{OH} \\ \diagdown \quad / \\ \text{C} \\ / \quad \diagdown \\ \text{H}_3\text{C} \quad \text{CN} \end{array}$   
 D)  $\begin{array}{c} \text{O} \\ || \\ \text{H}_3\text{C}-\text{C}-\text{CN} \end{array}$

Q.5 Iodoform test will not be positive with:

- A)  $\text{H}_3\text{C}-\text{CH}_2-\overset{\text{O}}{\parallel}{\text{C}}-\text{CH}_2-\text{CH}_3$   
 B)  $\text{H}_3\text{C}-\text{CH}_2-\overset{\text{O}}{\parallel}{\text{C}}-\text{CH}_3$   
 C)  $\text{C}_2\text{H}_5\text{OH}$   
 D)  $\text{H}_3\text{C}-\overset{\text{O}}{\parallel}{\text{C}}-\text{H}$

**Q.6** When  $\text{CH}_3\text{—CH}_2\text{—OH}$  is oxidized in the presence of  $\text{K}_2\text{Cr}_2\text{O}_7$  and  $\text{H}_2\text{SO}_4$ , the product formed is

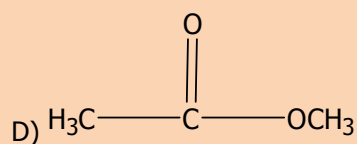
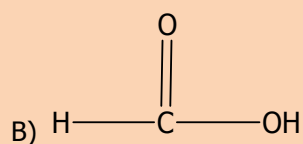
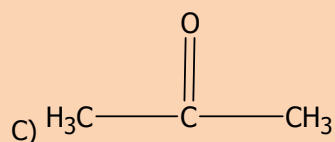
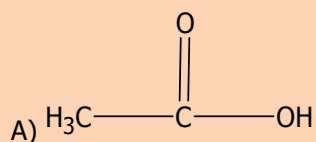

## 2013

**Q.7** Which group gives a yellow precipitate of triiodo methane when warmed with alkaline aqueous iodine?

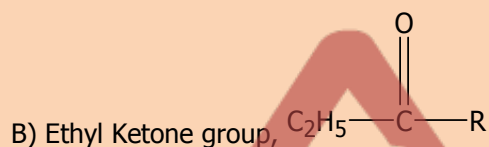
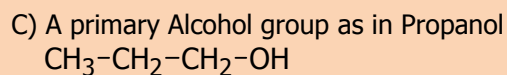
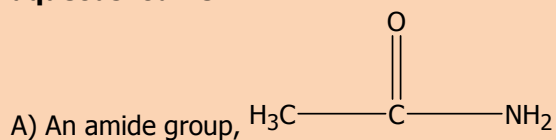

**Q.8** What is the structure of alcohol which on oxidation with acidified  $\text{Na}_2\text{Cr}_2\text{O}_7$  gives

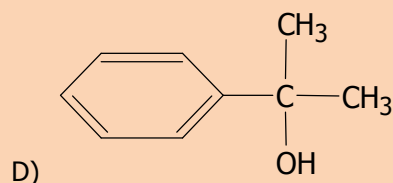
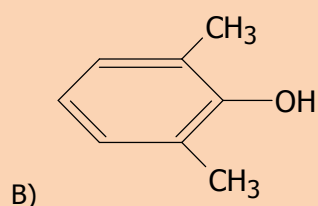
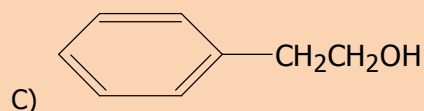
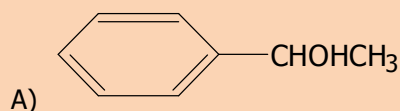
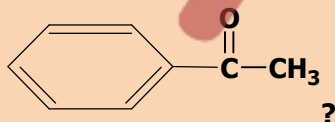

**Q.9** Which of the following is the structure of ketone?

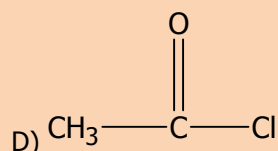
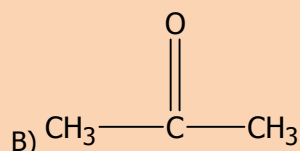
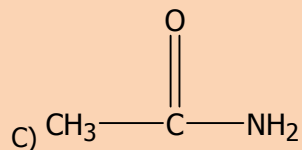
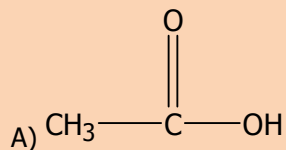

## 2014

**Q.10** A student mixed ethyl alcohol with small amount of sodium dichromate and added it to the hot solution of dilute sulphuric acid. A vigorous reaction took place. He distilled the product formed immediately. What was the product?

- A) Acetone  
B) Acetic acid  
C) Dimethyl ether  
D) Acetaldehyde

**Q.11** The structural formula of the product of reaction of acetone with 2, 4-dinitrophenyl hydrazine is:

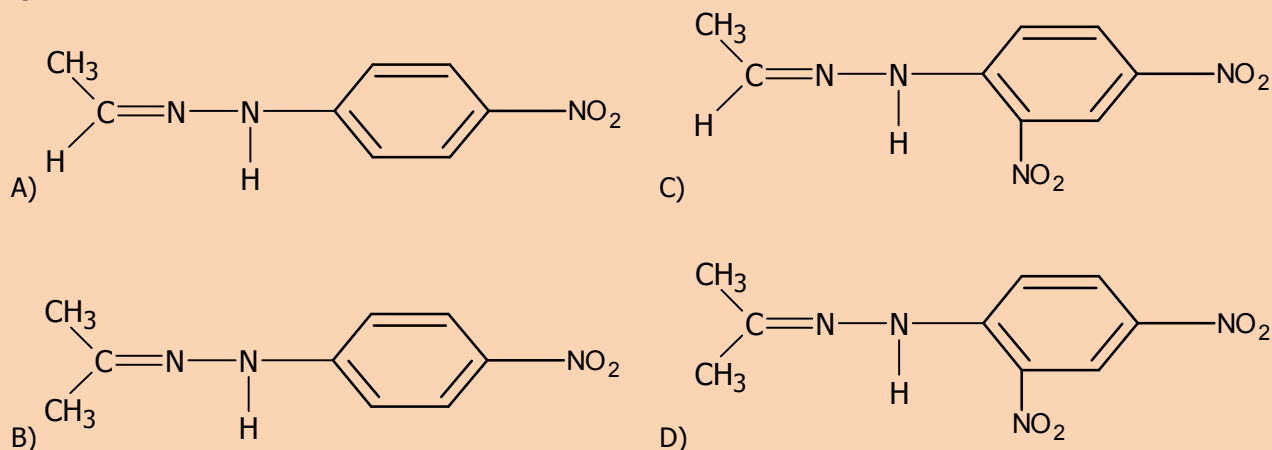

**Q.12** For the reaction:

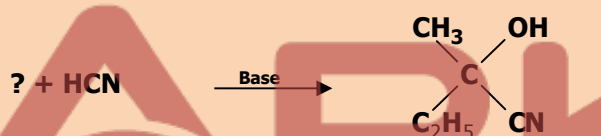

- A)  $\text{C}_2\text{H}_5\text{COCH}_3$   
B)  $\text{C}_2\text{H}_5\text{CH}(\text{CH}_3)\text{OH}$   
C)  $\text{CH}_3\text{COCH}_3$   
D)  $\text{C}_2\text{H}_5\text{CH}_2\text{CHO}$

## 2015

**Q.13** Which one of the following is also called silver mirror test?

- A) Fehling's solution test  
B) Iodoform test  
C) Tollen's reagent  
D) Benedict's solution tests

**Q.14** When acetaldehyde reacts with 2,4-dinitrophenylhydrazine (2,4-DNPH), which one of the following products is formed?

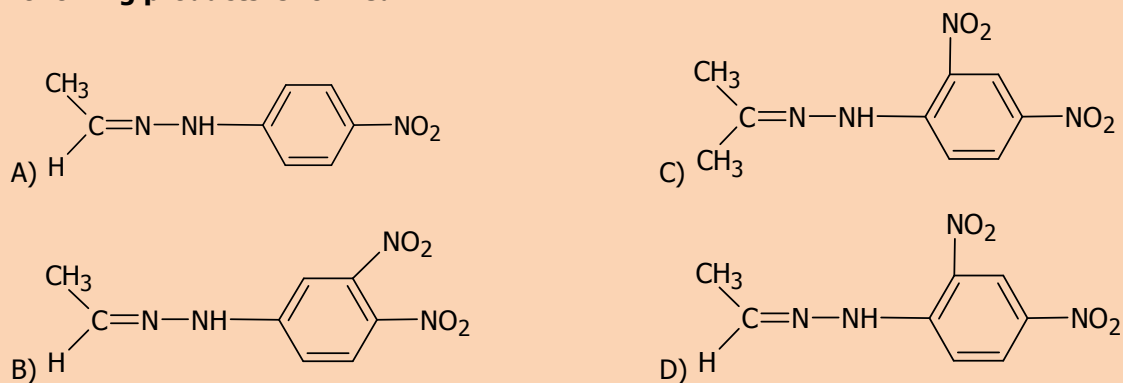

**Q.15** Both aldehydes and ketones are planer to the neighborhoods of carbonyl ( $\text{C}=\text{O}$ ) group. Which one of the following bonds is distorted towards the oxygen atoms?

- A)  $\pi$ -bond of C and O  
B) Sigma bond of C and H  
C) Sigma bond of C and O  
D) Sigma bond of C and C



## 2016

Q.16

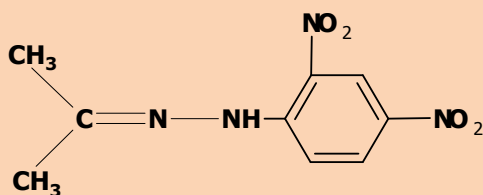

It is the general formula of:

- A) 2, 4-Dinitrophenyl hydrazine  
 B) 1, 3-Dinitrophenyl hydrazone  
 C) Phenyl hydrazone  
 D) 2, 4-Dinitrophenyl hydrazone

Q.17

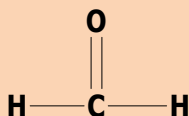

Which one of the following is the IUPAC name of above given structure:

- A) Propionaldehyde  
 B) Methanone  
 C) Acetaldehyde  
 D) Methanal

Q.18

Which one of the following test is given by both aldehyde and ketone?

- A) Silver mirror test  
 B) Fehling's solution test  
 C) 2, 4 DNPH test  
 D) Benedict's solution test

<b>ANSWERS</b>	Q.1	D	Q.7	D	Q.13	C
	Q.2	A	Q.8	A	Q.14	D
	Q.3	C	Q.9	B	Q.15	A
	Q.4	B	Q.10	D	Q.16	D
	Q.5	A	Q.11	D	Q.17	D
	Q.6	A	Q.12	A	Q.18	C

## 6C

## CARBOXYLIC ACIDS

## 2011

- Q.1**  $\text{CH}_3\text{COOH} + \text{PCl}_5 \longrightarrow ?$   
**The products of the above reaction are:**  
 A)  $\text{CH}_3\text{COI} + \text{POCl}_3 + \text{HCl}$   
 B)  $\text{CH}_3\text{COI} + \text{POCl}_2 + \text{HCl}$   
 C)  $\text{CH}_3\text{Cl} + \text{POCl}_3 + \text{HCl}$   
 D)  $\text{CH}_3\text{COCl} + \text{POCl}_3 + \text{H}_2$
- Q.2**  $\text{CH}_3\text{CN} + \text{HCl} \longrightarrow \text{A} + \text{B}$  (in the presence of water)  
**In the above reaction, A and B are:**  
 A) Acetic acid and acid amide  
 B) Acetic acid and ammonia  
 C) Acetic acid and methyl chloride  
 D) Acetic acid and ammonium chloride
- Q.3** Consider the following reaction:  
 $\text{CH}_3\text{COOH} + \text{Mg (metal)} \longrightarrow ?$   
**What product will form?**  
 A) Magnesium formate  
 B) Magnesium acetate  
 C) Magnesium ion  
 D) Carboxylate ion

## 2012

- Q.4** In the below reaction the nucleophile which attacks on the carbon atom of acid is:  

$$\text{CH}_3\text{COOH} + \text{PCl}_5 \longrightarrow \text{H}_3\text{C}-\overset{\text{O}}{\parallel}{\text{C}}-\text{Cl} + \text{POCl}_3 + \text{HCl}$$
  
 A)  $\text{OH}^-$   
 B) P  
 C)  $\text{Cl}^-$   
 D)  $\text{H}^-$
- Q.5** When ethanol chloride reacts with methylamine, an amide is formed. What is the structure of the amide formed?  
 A)  $\text{H}_3\text{C}-\text{CH}_2-\overset{\text{O}}{\parallel}{\text{C}}-\text{NH}_2$   
 B)  $\text{H}_3\text{C}-\text{CH}_2-\overset{\text{O}}{\parallel}{\text{C}}-\text{NHCH}_3$   
 C)  $\text{H}_3\text{C}-\overset{\text{O}}{\parallel}{\text{C}}-\text{NH}_2$   
 D)  $\text{H}_3\text{C}-\overset{\text{O}}{\parallel}{\text{C}}-\text{NHCH}_3$
- Q.6** Primary alcohols normally give us aldehydes when oxidized in the presence of  $\text{Na}_2\text{Cr}_2\text{O}_7$ , what the product will be, when the secondary alcohols are oxidized in same conditions?  
 A) Alkenes  
 B) Alkynes  
 C) Alkyl halides  
 D) Ketones

## 2013

- Q.7** The formation of ester from acetic acid in presence of acid and ethanol is a:  
 A) Nucleophilic substitution reaction  
 B) Nucleophilic addition reaction  
 C) Electrophilic substitution reaction  
 D) Electrophilic addition reaction

- Q.8 Methyl cyanides, on boiling with mineral acids or alkalis yield:**  
 A) Acetic acid  
 B) Formic acid  
 C) Propanoic acid  
 D) Butanoic acid

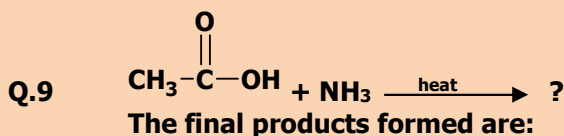

- A)  $\text{CH}_3-\overset{\text{O}}{\parallel}{\text{C}}-\text{NH}_2 + \text{CO}_2$   
 B)  $\text{CH}_3-\overset{\text{O}}{\parallel}{\text{C}}-\text{NH}_2 + \text{H}_2\text{O}$   
 C)  $\text{CH}_3-\overset{\text{O}}{\parallel}{\text{C}}-\text{NH}_2 + \text{H}_2$   
 D)  $\text{CH}_3-\overset{\text{O}}{\parallel}{\text{C}}-\text{NH}_2 + \text{HCl}$

## 2014

- Q.10 Ethyl butyrate and butyl butanoate are esters with the flavor of**  
 A) Pear  
 B) Banana  
 C) Pineapple  
 D) Apple
- Q.11 Acetamide is formed by dehydration of**  
 A) Oxalic acid  
 B) Ethanoic acid  
 C) Butanoic acid  
 D) Propanoic acid
- Q.12 Organic compounds 'X' and 'Y' both can react with Na-Metal to evolve hydrogen gas. If 'X' and 'Y' react with each other form an organic compound 'Z' which gives fruity smell. What type of compound 'X', 'Y' and 'Z' are?**

	X	Y	Z
A)	Alcohol	Ester	Acetic Acid
B)	Alcohol	Ester	Mineral Acid
C)	Alcohol	Acetic Acid	Ester
D)	Alcohol	Mineral Acid	Ester

## 2015

- Q.13 'K<sub>a</sub>' values of few organic acids are given:**

Acid	K <sub>a</sub> Value
CH <sub>3</sub> COOH	1.85 × 10 <sup>-5</sup>
CCl <sub>3</sub> COOH	2.3 × 10 <sup>-2</sup>
CHCl <sub>2</sub> COOH	5.0 × 10 <sup>-3</sup>
CH <sub>2</sub> ClCOOH	1.3 × 10 <sup>-3</sup>

**The order of acid strength is:**

- A) CCl<sub>3</sub>COOH > CHCl<sub>2</sub>COOH > CH<sub>2</sub>ClCOOH > CH<sub>3</sub>COOH  
 B) CH<sub>3</sub>COOH > CHCl<sub>2</sub>COOH > CCl<sub>3</sub>COOH > CH<sub>2</sub>ClCOOH  
 C) CHCl<sub>2</sub>COOH > CH<sub>3</sub>COOH > CCl<sub>3</sub>COOH > CH<sub>2</sub>ClCOOH  
 D) CCl<sub>3</sub>COOH > CH<sub>3</sub>COOH > CHCl<sub>2</sub>COOH > CH<sub>2</sub>ClCOOH
- Q.14 An organic acid 'z' reacts separately with sodium bicarbonate, sodium hydroxide and sodium carbonate. Which one of the following represent the structure of 'z'?**  
 A) HCOOC<sub>2</sub>H<sub>5</sub>  
 B) CH<sub>3</sub>-CH=CH<sub>2</sub>  
 C) CH<sub>3</sub>CH<sub>2</sub>OH  
 D) H<sub>3</sub>C-CH<sub>2</sub>-COOH

**Q.15** Carboxylic acids are rather hard to reduce, which powerful reducing agent can be used to convert them to the corresponding primary alcohol:

- A)  $\text{H}_2\text{SO}_4/\text{HgSO}_4$   
 B)  $\text{V}_2\text{O}_5$

- C)  $\text{LiAlH}_4$   
 D)  $\text{K}_2\text{Cr}_2\text{O}_7/\text{H}_2\text{SO}_4$

## 2016

**Q.16**  $\text{CH}_3\text{COOH} + \text{CH}_3\text{CH}_2\text{OH} \rightleftharpoons \text{CH}_3\text{COOC}_2\text{H}_5 + \text{H}_2\text{O}$

Which one of the following will act as a catalyst in above reaction?

- A)  $\text{HNO}_3$   
 B)  $\text{H}_2\text{SO}_4$

- C) Acidified potassium dichromate  
 D)  $\text{SOCl}_2$

**Q.17**  $\text{CH}_3\text{COOH} + \text{PCl}_5 \longrightarrow ?$

Which one of the following options shows the products of above reaction?

- A)  $\text{POCl}_2 + \text{CH}_3\text{COCl}_2 + \text{HCl}$   
 B)  $\text{POCl}_3 + \text{CH}_3\text{COCl}_2 + \text{H}_2$

- C)  $\text{CH}_3\text{COCl} + \text{POCl}_2 + \text{HCl}$   
 D)  $\text{POCl}_3 + \text{CH}_3\text{COCl} + \text{HCl}$

**Q.18** Which one of the following reaction of carboxylic acid is reversible?

- A) Esterification  
 B) Salt formation

- C) Reaction with  $\text{PCl}_5$   
 D) Reaction with  $\text{SOCl}_2$

<b>ANSWERS</b>	<b>Q.1</b>	A	<b>Q.7</b>	A	<b>Q.13</b>	A
	<b>Q.2</b>	D	<b>Q.8</b>	A	<b>Q.14</b>	D
	<b>Q.3</b>	B	<b>Q.9</b>	B	<b>Q.15</b>	C
	<b>Q.4</b>	C	<b>Q.10</b>	C	<b>Q.16</b>	B
	<b>Q.5</b>	D	<b>Q.11</b>	B	<b>Q.17</b>	D
	<b>Q.6</b>	D	<b>Q.12</b>	C	<b>Q.18</b>	A

7C

## AMINO ACIDS

2011

**Q.1 The —NH—CO is called:**

- A) Amide group  
 B) Amino group  
 C) Protein linkage  
 D) Peptide linkage

**Q.2 Which one of the following is an alpha amino acid?**

- A)  $\begin{array}{c} \text{H}_3\text{C}-\text{CH}-\text{COOH} \\ | \\ \text{NH}_2 \end{array}$   
 B)  $\begin{array}{c} \text{H} \\ | \\ \text{H}_3\text{C}-\text{C}-\text{COOH} \\ | \\ \text{H}_2\text{C}-\text{NH}_2 \end{array}$   
 C)  $\begin{array}{c} \text{H}_3\text{C}-\text{CH}-\text{CH}_2-\text{COOH} \\ | \\ \text{NH}_2 \end{array}$   
 D)  $\begin{array}{c} \text{H} \\ | \\ \text{H}_3\text{C}-\text{C}-\text{CH}-\text{CH}_3 \\ | \quad | \\ \text{HOOC} \quad \text{NH}_2 \end{array}$

**Q.3 Which of the following has an amino R-group?**

- A) Lysine  
 B) Proline  
 C) Valine  
 D) Alanine

**Q.4 At intermediate value of pH, amino acids form Zwitter ions containing:**

- A)  $-\text{N}^+\text{H}_3$  and  $\text{COO}-$   
 B)  $-\text{NH}_3$  and  $\text{COO}-$   
 C)  $-\text{N}^+\text{H}_3$  and  $\text{COOH}$   
 D)  $-\text{NH}_3$  and  $\text{COOH}$

**Q.5 A polymer in which the number of amino acid residue is greater than 100 or molecular mass is greater than 1000, is known as:**

- A) Protein  
 B) Polypeptide  
 C) Dipeptide  
 D) Tripeptide

**Q.6 Aspartic acid is an acidic amino acid, which has chemical formula:**

- A)  $\begin{array}{c} \text{H}_3\text{C}-\text{CH}-\text{COOH} \\ | \\ \text{NH}_2 \end{array}$   
 B)  $\begin{array}{c} \text{H} \\ | \\ \text{H}_2\text{N}-\text{C}-\text{COOH} \\ | \\ \text{H}_2\text{C}-\text{COOH} \end{array}$   
 C)  $\begin{array}{c} \text{H}_3\text{C}-\text{CH}-\text{CH}_2-\text{COOH} \\ | \\ \text{NH}_2 \end{array}$   
 D)  $\begin{array}{c} \text{H} \\ | \\ \text{H}_3\text{C}-\text{C}-\text{CH}-\text{COOH} \\ | \quad | \\ \text{H} \quad \text{NH}_2 \end{array}$

2012

**Q.7 Organic compound containing both amine and carboxyl group is known as**

- A) Amino acid  
 B) Fatty acid  
 C) Saccharide  
 D) Amide

**Q.8 Alanine is an amino acid which shows neutral effect on litmus paper, the formula of alanine may be**

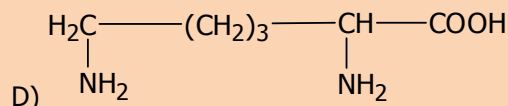
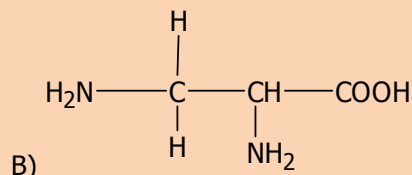
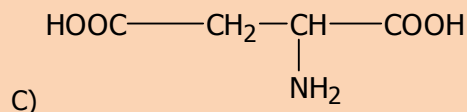
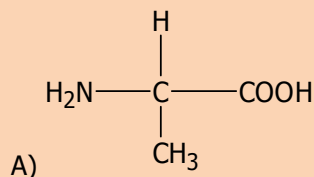

**Q.9 Which of the following structures is not an alpha amino acid?**

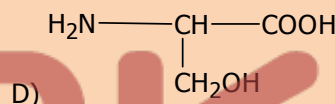
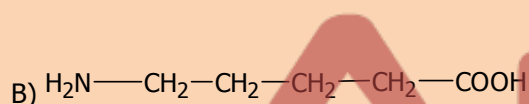
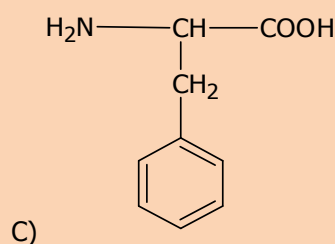
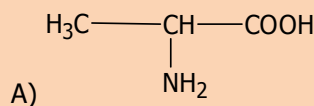

**Q.10 The skeletal formula of dipeptide formed between aspartic acid and phenylalanine is given below:**

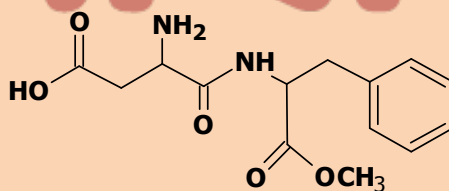

**How many functional groups are present in its formula?**

- A) 1  
B) 2

- C) 4  
D) 3

**Q.11 In basic conditions, amino acid exists in which of the following forms?**

- A)  $\text{H}_3\text{N}^+-\text{CH}_2-\text{COOH}$   
B)  $\text{H}_2\text{N}-\text{CH}_2-\text{COOH}$

- C)  $\text{H}_3\text{N}^+-\text{CH}_2-\text{COO}^-$   
D)  $\text{H}_2\text{N}-\text{CH}_2-\text{COO}^-$

**Q.12 Structure of dipeptide is**

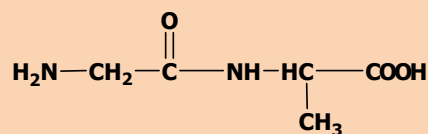

**This is called:**

- A) Glycyl glycine  
C) Glycyl alanine

- C) Alaninyl alanine  
D) Alaninyl glycine

## 2013

**Q.13 The amino acids which largely exist in dipolar ionic form are:**

- A) Acidic amino acids  
 B) Basic amino acids  
 C) Beta amino acids  
 D) Alpha amino acids

**Q.14 The reaction:**

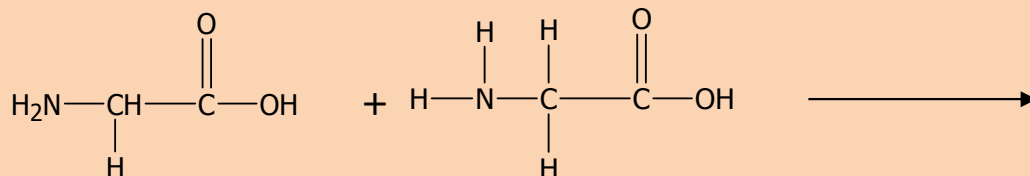

**Gives a product called dipeptide molecule represented by:**

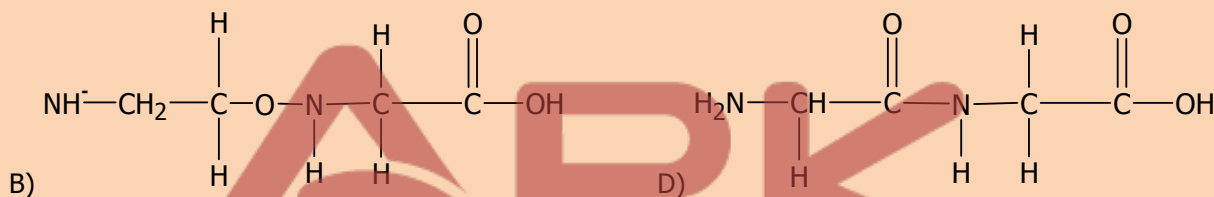
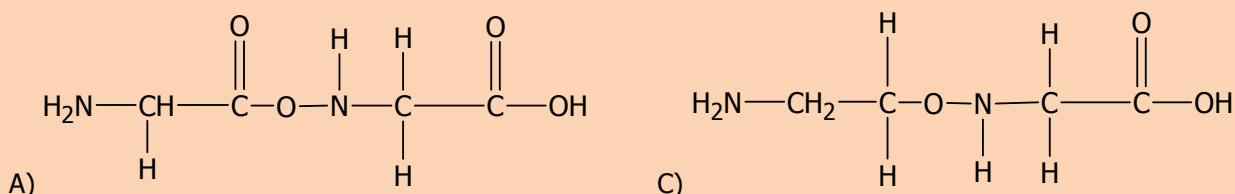

**Q.15 Two or more amino acids condensed to form protein by a peptide linkage which is resented between two atoms:**

- A) C and C  
 B) O and C  
 C) C and N  
 D) C and H

**Q.16  $\alpha$ -amino acids are compounds having carboxylic acid as well as amino functional groups attached to:**

- A) Any H-atom in the molecule  
 B) Same carbon atom  
 C) Alternate carbon atoms  
 D) Neighboring carbon atoms

**Q.17 The formula of 'Zwitter ion' is represented by:**

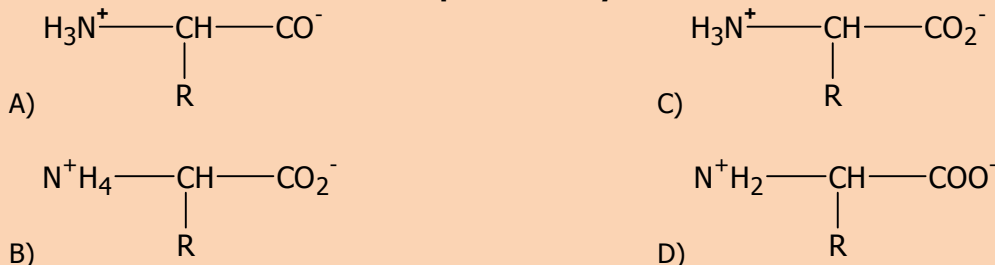

**Q.18 What is the name of amino acid,**

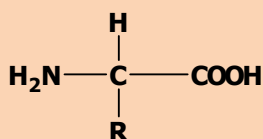

**where 'R' is CH<sub>3</sub> group?**

- A) Glycine  
 B) Lysine  
 C) Aspartic acid  
 D) Alanine

## 2014

- Q.19 The amino acids which are not prepared in human body are called**  
 A) Essential amino acids  
 B) Non-essential amino acids  
 C) Alpha amino acids  
 D) Beta amino acids

- Q.20 Indicate the cyclic amino acid from the following:**  
 A) Cysteine  
 B) Serine  
 C) Haloamine  
 D) Proline

- Q.21 Which one of the following is Glutamic Acid?**

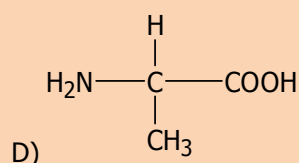
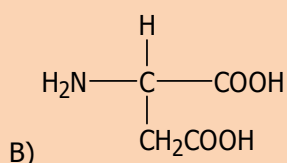
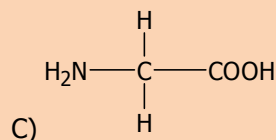
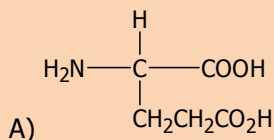

- Q.22 At low pH or in acidic condition amino acid exists as**  
 A) Anion  
 B) Cation  
 C) Zwitter ion  
 D) Neutral specie

- Q.23 The structure shown below represents:**

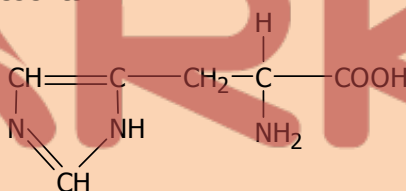

- A) Proline  
 B) Histidine  
 C) Glycine  
 D) Lysine
- Q.24 Which one of the following reagent is used for identification of amino acids?**  
 A) Fehling's solution  
 B) Benedict's solution  
 C) Ninhydrin  
 D) Copper (II) Sulphate

## 2015

- Q.25**

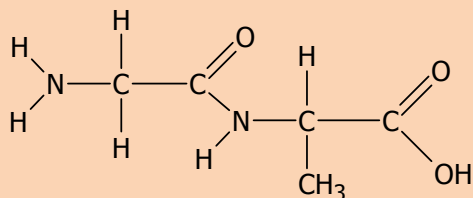

- This structure is**  
 A) Gly-Ala (dipeptide)  
 B) Asp-Gly (dipeptide)  
 C) Gly-Val (dipeptide)  
 D) Asp-Val (dipeptide)
- Q.26 Which one of the following amino acids is basic in nature?**  
 A) Glycine  
 B) Alanine  
 C) Lysine  
 D) Glutamic acid



**Q.27 Which one of the following structures shows the correct formula of glutamic acid?**

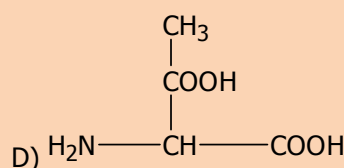
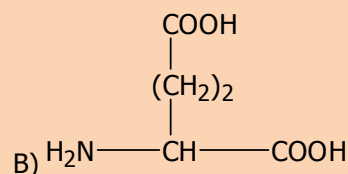
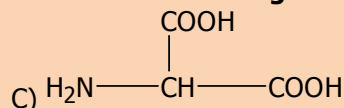
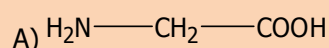

**Q.28 Select the correct Zwitter ionic structures of an amino acid.**

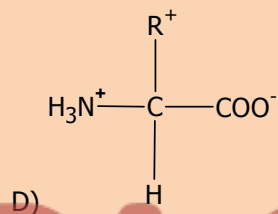
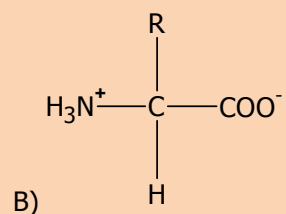
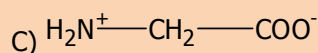
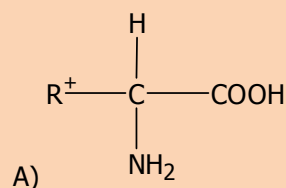

**Q.29 The structural formula for alanine is:**

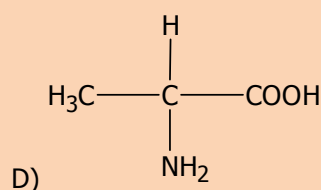
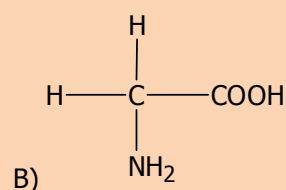
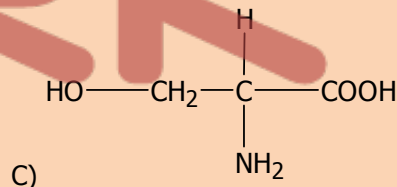
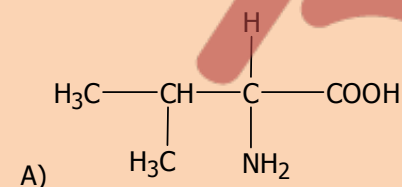

**Q.30 In  $\overset{4}{\text{C}}\text{H}_3-\overset{3}{\text{C}}\text{H}-\overset{2}{\text{C}}\text{H}-\overset{1}{\text{C}}\text{OOH}$  which one is  $\alpha$ -carbon atom?**

- A) 1  
B) 3

- C) 2  
D) 4

**2016**

**Q.31 In the formation of Zwitter ion which one of the following donates the proton?**

- A)  $\text{COOH}$   
B)  $\text{NH}_2$

- C)  $\text{CH}_2\text{COO}^-$   
D)  $\text{OH}^-$

**Q.32** Which one of the following is structural formula of proline?

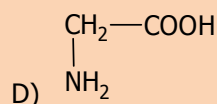
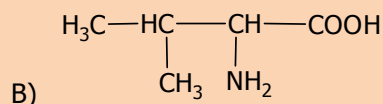
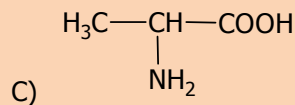
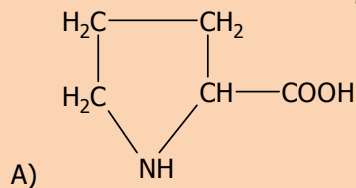

**Q.33**

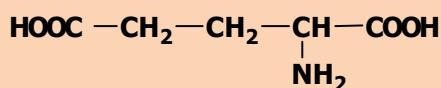

**What is the name of above given structural formula?**

- A) Aspartic Acid  
B) Asparagine

- C) Adipic Acid  
D) Glutamic Acid

**Q.34** Which one of the following is simplest amino acid?

- A) Lysine  
B) Leucine

- C) Alanine  
D) Glycine

**Q.35**

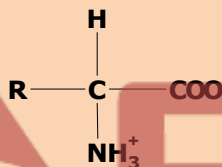

**Select the best option indicating the name of the above structure:**

- A) Cation  
B) Neutral amino acid

- C) Internal salt  
D) Anion

**Q.36** When acid is added to an amino acid, which one of the following will act as a base?

- A)  $\text{NH}_3^+$   
B)  $\text{COO}^-$

- C)  $\text{H}^+$   
D) R group

## ANSWERS

<b>Q.1</b>	D	<b>Q.10</b>	C	<b>Q.19</b>	A	<b>Q.28</b>	B
<b>Q.2</b>	A	<b>Q.11</b>	D	<b>Q.20</b>	D	<b>Q.29</b>	D
<b>Q.3</b>	A	<b>Q.12</b>	B	<b>Q.21</b>	A	<b>Q.30</b>	C
<b>Q.4</b>	A	<b>Q.13</b>	D	<b>Q.22</b>	B	<b>Q.31</b>	A
<b>Q.5</b>	A	<b>Q.14</b>	A	<b>Q.23</b>	B	<b>Q.32</b>	A
<b>Q.6</b>	B	<b>Q.15</b>	C	<b>Q.24</b>	C	<b>Q.33</b>	A
<b>Q.7</b>	A	<b>Q.16</b>	B	<b>Q.25</b>	A	<b>Q.34</b>	D
<b>Q.8</b>	A	<b>Q.17</b>	A	<b>Q.26</b>	C	<b>Q.35</b>	C
<b>Q.9</b>	B	<b>Q.18</b>	D	<b>Q.27</b>	B	<b>Q.36</b>	B

## 8C

## MACROMOLECULES

## 2011

- Q.1** When hexane dioic acid is heated with hexamethylene diamine, the compound formed is:  
 A) Polypeptide  
 B) Addition polymer  
 C) Ester  
 D) Nylon 6,6
- Q.2** Glucose and fructose are common examples of:  
 A) Pentoses  
 B) Hexoses  
 C) Heptoses  
 D) Butoses
- Q.3** The reaction between fats and caustic soda is called:  
 A) Hydrogenolysis  
 B) Fermentation  
 C) Carboxylation  
 D) Saponification
- Q.4** Macromolecules are described as large molecules built up from small repeating units known as:  
 A) Monomers  
 B) Isomers  
 C) Metameres  
 D) Tautomer
- Q.5** Polyvinyl chloride is an example of:  
 A) Addition polymer  
 B) Condensation polymer  
 C) Biopolymer  
 D) Thermosetting polymer
- Q.6** Terylene, a polyester is an example of:  
 A) Biopolymer  
 B) Lipids  
 C) Condensation polymer  
 D) Addition polymer

## 2012

- Q.7** The principle energy storage carbohydrate in animal's is  
 A) Glucose  
 B) Starch  
 C) Protein  
 D) Glycogen
- Q.8** Starch is a polymer of  
 A)  $\beta$ -D-glucose  
 B)  $\alpha$ -glucose  
 C)  $\gamma$ -D-glucose  
 D)  $\alpha$ -L-glucose
- Q.9** The reaction between fats and caustic soda is called  
 A) Hydrogenolysis  
 B) Fermentation  
 C) Esterification  
 D) Saponification
- Q.10** Adipic acid and hexamethylene diamine both of which have \_\_\_\_\_ carbon atoms:  
 A) Seven  
 B) Eight  
 C) Six  
 D) Four
- Q.11** Lactose is a sugar present in milk. It is an example of  
 A) Disaccharides  
 B) Monosaccharides  
 C) Polysaccharides  
 D) Starch

- Q.12 Macromolecules are described as large molecules built up from small repeating units called:**
- A) Monomers  
B) Isomers  
C) Metamers  
D) Tautomers

## 2013

- Q.13 Polyvinyl acetate (PVA) is colourless and non-toxic resin used as an adhesive and as a binder for making:**
- A) Toys  
B) Gramophone recorders  
C) Compact discs  
D) Emulsion paints
- Q.14 Both ribose and deoxyribose are monosaccharides containing \_\_\_\_\_ carbon atoms.**
- A) Four  
B) Six  
C) Five  
D) Seven
- Q.15 The increased quantities of cholesterol in blood make plaque like deposits in the arteries causing:**
- A) Cholera  
B) Down's syndrome  
C) Heart attack  
D) Phenylketonuria
- Q.16 Polyvinyl chloride is an example of:**
- A) Condensation polymer  
B) Addition polymer  
C) Biopolymer  
D) Thermosetting polymer
- Q.17 Collagen is a fibrous protein present most abundantly in:**
- A) Hair  
B) Nail  
C) Tendons  
D) Arteries
- Q.18 Animals store glucose in the form of glycogen in:**
- A) Stomach  
B) Mouth  
C) Liver and muscles  
D) Small intestine

## 2014

- Q.19 Which one of the following is an example of condensation polymer?**
- A) Polyvinylchloride  
B) Polystyrene  
C) Polyethene  
D) Polyamide
- Q.20 Among the most common disaccharides, which one of the followings is present in the milk?**
- A) Sucrose  
B) Maltose  
C) Fructose  
D) Lactose
- Q.21 Fats are a type of lipid called glycerides. They are esters of long chain carboxylic acids:**
- A) Propene-1, 2, 3-triol  
B) Propane-1, 2, 3-triol  
C) Propene-1, 2, 3-diol  
D) Propane-1, 2, 3-diol
- Q.22 Which one of the following base is NOT present in RNA?**
- A) Cytosine  
B) Adenine  
C) Thymine  
D) Guanine
- Q.23 Collagen proteins are present in \_\_\_\_\_ throughout the body**
- A) Muscle  
B) Red blood cells  
C) Tendons  
D) Blood plasma
- Q.24 Polystyrene is an addition polymer. Which one of the following structures represents the monomer of polystyrene?**
- A)  $\text{CH}_2=\text{CH}_2$   
B)  $\text{CH}_2=\text{CH}-\text{CH}_3$   
C)  $\text{CH}_2=\text{CH}-\text{Cl}$   
D)  $\text{CH}_2=\text{CH}-\text{C}_6\text{H}_5$

## 2015

**Q.25** The specific substances (metabolite) that fits on the enzyme surface and is converted to products is called

- A) Co-factor  
B) Prosthetic group  
C) Isoenzyme  
D) Substrate

**Q.26** Polyamide is formed due to the condensation of hexane-dioic acid with

- A) Hexane-1,5-diamine  
B) Hexane-1,6-diamine  
C) Hexane-1,4-diamine  
D) Hexane-2,5-diamine

**Q.27** Haemoglobin is a

- A) Genetic protein  
B) Building protein  
C) Transport protein  
D) Structural protein

**Q.28** Which one of the following polymer is polystyrene?

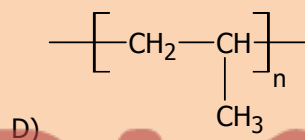
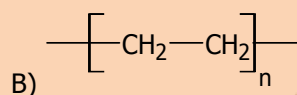
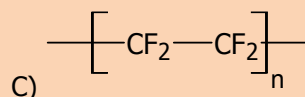
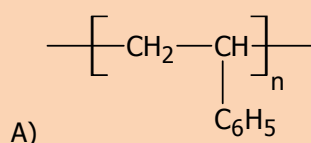

**Q.29** Out of these which nitrogen base is NOT present in DNA?

- A) Adenine  
B) Guanine  
C) Uracil  
D) Thymine

**Q.30** Which one of the following is an example of co-polymer?

- A) Polyamide  
B) Polystyrene  
C) Polyvinyl acetate  
D) Polyvinyl chloride

## 2016

**Q.31** Which one of the following polymer is called as Nylon 6,6?

- A) Polyester  
B) Polyvinyl chloride  
C) Polyamide  
D) Polyvinyl acetate

**Q.32** Which one of the following is an exact composition of a carbohydrates?

- A) Carbon and Hydrogen  
B) Carbon and Oxygen  
C) Carbon, Hydrogen and Oxygen  
D) Hydrogen and Oxygen

**Q.33** Which one of the following nitrogen base is NOT present in DNA?

- A) Adenine  
B) Guanine  
C) Uracil  
D) Cytosine

**Q.34** In the woody parts of trees, the %age of cellulose is:

- A) 50%  
B) 10%  
C) 30%  
D) 100%

**Q.35** In laboratory experiment an unknown compound was added in test tube containing iodine, the colour became intense blue. What could be the unknown compound?

- A) Cellulose  
C) Ribose

Q.36

B) Raffinose

D) Starch

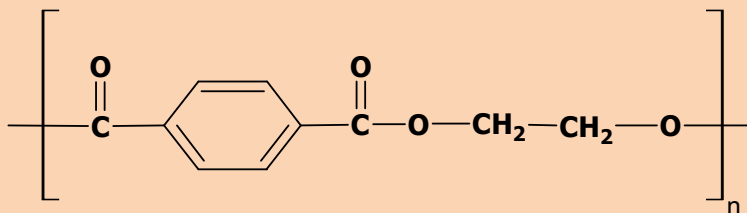

Indicate the name of above given structure.

A) Nylon 6,6  
B) Adipic Acid

C) PVA  
D) Polyester

<b>ANSWERS</b>	Q.1	D	Q.10	C	Q.19	D	Q.28	A
	Q.2	B	Q.11	A	Q.20	D	Q.29	C
	Q.3	D	Q.12	A	Q.21	B	Q.30	A
	Q.4	A	Q.13	D	Q.22	C	Q.31	C
	Q.5	A	Q.14	C	Q.23	C	Q.32	C
	Q.6	C	Q.15	C	Q.24	D	Q.33	C
	Q.7	D	Q.16	B	Q.25	D	Q.34	D
	Q.8	B	Q.17	C	Q.26	B	Q.35	D
	Q.9	D	Q.18	C	Q.27	C	Q.36	C

9C

## ENVIRONMENTAL CHEMISTRY

## 2011

- Q.1 The suspected liver carcinogen which also has negative reproduction and developmental effect on humans is:**  
 A) Iodoform  
 B) Bromoform  
 C) Tropoform  
 D) Chloroform
- Q.2 Peroxyacetyl nitrate is an irritant to human beings and its effects:**  
 A) Nose  
 B) Stomach  
 C) Ears  
 D) Eyes

## 2012

- Q.3 The increase in concentration of oxidizing agents in smog like  $\text{H}_2\text{O}_2$ ,  $\text{HNO}_3$ , PAN and ozone in the air is called**  
 A) Carbonated smog  
 B) Nitrated smog  
 C) Photochemical smog  
 D) Sulphonated smog
- Q.4 Which is the metal, whose elevated concentration is harmful for fish as it clogs the gills thus causing suffocation?**  
 A) Sodium  
 B) Lead  
 C) Zinc  
 D) Aluminium

## 2013

- Q.5 Aerobic decomposition of organic matter i.e. glucose by bacteria in water sediments produces:**  
 A) Propene  
 B) Ethane  
 C) Methane  
 D) Butane
- Q.6 The yellowish-brown color in photochemical smog is due to the presence of:**  
 A) Sulphur dioxide  
 B) Carbon monoxide  
 C) Carbon dioxide  
 D) Nitrogen dioxide

## 2014

- Q.7 \_\_\_\_\_ is an eye irritant.**  
 A) Peroxyacetyl nitrate  
 B) Peroxyacetyl nitrite  
 C) Peroxymethoxy aniline  
 D) Peroxyacetyl aniline
- Q.8 Which one of the following pollutants can cause death of a person by binding with haemoglobin of red blood cells?**  
 A) Chlorofluorocarbons  
 B) Oxides of Sulphur  
 C) Carbon monoxide  
 D) Oxides of nitrogen

## 2015

- Q.9** The biggest source of acid rain is the oxide of  
 A) N C) O  
 B) S D) C
- Q.10** Burning of which one of the following waste is considered as useful industrial fuel or to produce electricity  
 A) Metals C) Paper  
 B) Grass D) Plastic

## 2016

- Q.11** Ozone concentration is measured in:  
 A) Debye units C) Debye units  
 B) Dupont units D) Dobson units
- Q.12** The gas which is mainly produced in landfills from the waste is:  
 A) CH<sub>4</sub> C) SO<sub>2</sub>  
 B) CO<sub>2</sub> D) Cl<sub>2</sub>

<b>ANSWERS</b>	<b>Q.1</b>	D	<b>Q.7</b>	A
	<b>Q.2</b>	D	<b>Q.8</b>	C
	<b>Q.3</b>	C	<b>Q.9</b>	B
	<b>Q.4</b>	D	<b>Q.10</b>	D
	<b>Q.5</b>	C	<b>Q.11</b>	D
	<b>Q.6</b>	D	<b>Q.12</b>	A

(MCAT Preparations 2017 – ARK)  
 (Copyrights Protected MCAT Preparations 2017 – ARK)



2008-2016

# MEDICAL COLLEGE APTITUDE TEST - ENGLISH

UHS, LAHORE

PAST PAPERS UNIT WISE MCQs

Ali Raza  
ARK



# Table of Specification



NO.	UNIT NAME	MCQs
1.	CHOOSE THE SUITABLE WORD	4
2.	SPOT THE ERROR	6
3.	CHOOSE THE CORRECT SENTENCE	10
4.	VOCABULARY (ESSENTIAL WORD POWER)	10
TOTAL:		30

ARK



## Contents

NO.	UNIT NAME	PAGE NO.
1.	CHOOSE THE SUITABLE WORD	4
2.	SPOT THE ERROR	9
3.	CHOOSE THE CORRECT SENTENCE	15
4.	VOCABULARY (ESSENTIAL WORD POWER)	27

ARK



CHOOSE SUITABLE WORD

---

⇒ **CHOOSE THE SUITABLE WORD.**

## 2008

- Q.1** He was \_\_\_\_\_ of all valuable possessions.  
 A) Robbed. C) Pinched.  
 B) Stolen. D) Established.
- Q.2** The presence of armed guards \_\_\_\_\_ us from doing anything disruptive.  
 A) Defeated. C) Irritated.  
 B) Excited. D) Prevented.
- Q.3** Our flight was \_\_\_\_\_ from Lahore to Islamabad airport.  
 A) Diverted. C) Deflected.  
 B) Reflected. D) Shifted.
- Q.4** I am \_\_\_\_\_ forward to our picnic scheduled in next month.  
 A) Looking. C) Seeing.  
 B) Planning. D) Going.

## 2009

- Q.5** The traveler \_\_\_\_\_ a long detour to water the camels.  
 A) Took C) Sought  
 B) Saw D) Made
- Q.6** Shah Jahan \_\_\_\_\_ the great mosque at Delhi.  
 A) Founded C) Created  
 B) Raised D) Established
- Q.7** He was \_\_\_\_\_ of theft in the court.  
 A) Charged C) Blamed  
 B) Reported D) Accused
- Q.8** He \_\_\_\_\_ on a very extraordinary ambition.  
 A) Arrived C) Came  
 B) Decided D) Hit

## 2010

- Q.9** My advice had no \_\_\_\_\_ on him.  
 A) Effect C) Influence  
 B) Affect D) Impression
- Q.10** Do not lose heart, it is just a \_\_\_\_\_ in the tea cup  
 A) Wind C) Blast  
 B) Cyclone D) Storm
- Q.11** Pakistan \_\_\_\_\_ from voting against Iran in the United Nations  
 A) Prevented C) Abstained  
 B) Detained D) Refused
- Q.12** Please \_\_\_\_\_ the door after you.  
 A) Close C) Leave  
 B) Shut D) Knock

## 2011

- Q.13** She managed to \_\_\_\_\_ a ticket for the cricket match.  
 A) Procure C) Improvise  
 B) Obscure D) Preclude
- Q.14** Things have got out of hand; we must take steps to \_\_\_\_\_ the situation  
 A) Rectify C) Purify  
 B) Pacify D) Testify
- Q.15** George Orwell's animal farm is a stinging \_\_\_\_\_ on the Russian revolution  
 A) Myth C) Fallacy  
 B) Satire D) Legend
- Q.16** All the \_\_\_\_\_ and ceremony of the royal wedding was telecast on the national television circuit.  
 A) Festival C) Pomp  
 B) Romp D) Happiness

## 2012

- Q.17** He had a heart attack and all attempts to \_\_\_\_\_ him failed.  
 A) Renew C) Revise  
 B) Resuscitate D) Refurnish
- Q.18** The \_\_\_\_\_ stench of dead animals and plants made Mumtaz ill.  
 A) Putrid C) Perturbed  
 B) Purified D) Purchased
- Q.19** While going up the hills, by bus, she felt \_\_\_\_\_ inside.  
 A) Fishy C) Queasy  
 B) Itchy D) Squeezy
- Q.20** The craft statesman manipulated the situation by making false promises and declaring sport festivities as a \_\_\_\_\_ to fool the public.  
 A) Red-Hearing C) Red-Herring  
 B) Red-Feather D) Red-Haring

## 2013

- Q.21** Indolence gives vent to \_\_\_\_\_ disposition in human life.  
 A) Static C) Energetic  
 B) Enthusiastic D) Filthy
- Q.22** The Quaid's \_\_\_\_\_ enthusiasm led the Muslims Indo-Pak to independence.  
 A) Simplified C) Onerous  
 B) Latent D) Threatening
- Q.23** He \_\_\_\_\_ the incident to the back of his mind.  
 A) Revered C) Reagitated  
 B) Regulated D) Relegated
- Q.24** He \_\_\_\_\_ the day they had bought such a large house  
 A) Hues C) Rues  
 B) Rows D) Dues

## 2014

- Q.25** It is our national duty to \_\_\_\_\_ our vote in the general election.  
 A) Throw C) Drop  
 B) Cast D) Refuse
- Q.26** She is intelligent enough to \_\_\_\_\_ things to serve her own purpose.  
 A) Pick C) Give  
 B) Maneuver D) Take
- Q.27** She \_\_\_\_\_ about the excitement on hearing the news of her sister's wedding.  
 A) Ran C) Talked  
 B) Jigged D) Wept
- Q.28** Everyone should be \_\_\_\_\_ duties and assignments according to his/her abilities.  
 A) Prevented C) Delegated  
 B) Advised D) Suggested

## 2015

- Q.29** In spite of all the torture, the police has failed to \_\_\_\_\_ any confession from the thief.  
 A) Convince C) Refuse  
 B) Elicit D) Agree
- Q.30** It is the duty of a teacher to \_\_\_\_\_ moral values in his students besides teaching.  
 A) Tell C) Inculcate  
 B) Record D) Suggest
- Q.31** Many of the houses in Murree have basic \_\_\_\_\_.  
 A) Amenities C) Affinity  
 B) Accuracy D) Array
- Q.32** Youngsters who indulge in love affairs are usually \_\_\_\_\_ in worldly manners.  
 A) Adjoined C) Adjured  
 B) Addled D) Adhesive

## 2016

- Q.33** His theories have been \_\_\_\_\_ by recent research.  
 A) Pronounced C) Dammed  
 B) Rearmed D) Debunked
- Q.34** International rules \_\_\_\_\_ the number of foreign entrants.  
 A) Hoodwink C) Fabricate  
 B) Stipulate D) Traverse
- Q.35** The assassination of the president \_\_\_\_\_ the country into war.  
 A) Articulated C) Hobbled  
 B) Boomed D) Precipitated
- Q.36** She might be forgiven for \_\_\_\_\_ beneath the pressure.  
 A) Undertaking C) Buckling  
 B) Extricating D) Resounding

<b>ANSWERS</b>	<b>Q.1</b>	A	<b>Q.13</b>	A	<b>Q.25</b>	B
	<b>Q.2</b>	D	<b>Q.14</b>	A	<b>Q.26</b>	B
	<b>Q.3</b>	A	<b>Q.15</b>	B	<b>Q.27</b>	B
	<b>Q.4</b>	A	<b>Q.16</b>	C	<b>Q.28</b>	C
	<b>Q.5</b>	D	<b>Q.17</b>	B	<b>Q.29</b>	B
	<b>Q.6</b>	A	<b>Q.18</b>	A	<b>Q.30</b>	C
	<b>Q.7</b>	D	<b>Q.19</b>	C	<b>Q.31</b>	A
	<b>Q.8</b>	D	<b>Q.20</b>	C	<b>Q.32</b>	B
	<b>Q.9</b>	A	<b>Q.21</b>	A	<b>Q.33</b>	<b>X</b>
	<b>Q.10</b>	D	<b>Q.22</b>	C	<b>Q.34</b>	B
	<b>Q.11</b>	C	<b>Q.23</b>	D	<b>Q.35</b>	D
	<b>Q.12</b>	B	<b>Q.24</b>	C	<b>Q.36</b>	C

The logo for ARK, featuring a stylized 'A' with a curved underline, followed by the letters 'R' and 'K' in a bold, sans-serif font.







**SPOT THE ERROR:** In the following sentences, some segments of each sentence are underlined. Your task is to identify that underlined segment of the sentence, which contains the mistake that needs to be corrected. Fill the Circle corresponding to that letter under the segment in the MCQ Response Form.

## 2008

- Q.1** They did not guess how closely he had kept in touch with across the road.  
A) B) C) D)
- Q.2** He proved that if only germs were excluded of wounds, inflammation was averted.  
A) B) C) D)
- Q.3** The man felt his hair flutter and the tissues of his body drew tight as if he were standing at the centre of a vacuum.  
A) B) C) D)
- Q.4** He came to the hurdles that he remember, over which once he had so easy a victory.  
A) B) C) D)
- Q.5** What is meant by birth-rate and death-rate and how do the effect the population?  
A) B) C) D)
- Q.6** She had left him with a calmness and a poise that accord well with his own inward emotions.  
A) B) C) D)

## 2009

- Q.7** He is better than all the boys in the class, in studies as well as in sports, and bags big prizes in various field.  
A) B) C) D)
- Q.8** One must not depend too much upon one's hard work, as provident also plays its part.  
A) B) C) D)
- Q.9** His first adventure was to go round through the world at minimum cost.  
A) B) C) D)
- Q.10** He has been working in this department since the last five years without any break.  
A) B) C) D)
- Q.11** He reached at Lahore only a few days ago, on last Friday, to be exact, and is going to stay here for some time.  
A) B) C) D)
- Q.12** There was a big rally on the Mall, but as the crowd disintegrated, chaos and confusion ruled everywhere.  
A) B) C) D)

## 2010

- Q.13** Suddenly he stopped at the edge of the meadow, taking his pocket knife from his pocket, and cut a wisp of alfalfa.  
A) B) C) D)
- Q.14** The study of population growth indicates one of the greatest paradox of our time.  
A) B) C) D)

- Q.15** Among the Western nations, the decline in the death rate is followed after an interval by the reduction in the birth rate, so that the population is not now growing so fast.  
 A) B)  
 C) D)
- Q.16** In view of increasing hazards with our national security it is the duty of every citizen to keep a watch on his surroundings.  
 A) B) C)  
 D)
- Q.17** Thrifty housewives preserved their homegrown vegetables and fruits in canning, pickling or drying them for use during the cold weather.  
 A) B)  
 C) D)
- Q.18** When a low-wage category worker finds he has to maintain a large family, his expenses may exceeds his income.  
 A) B) C)  
 D)

## 2011

- Q.19** The patient's blood analysis shows that there is a big number of amorphous cells which are quiet unidentifiable.  
 A) B) C) D)
- Q.20** The police, in their investigation, used coercive measure to get favorable statement from the accused.  
 A) B) C) D)
- Q.21** Your argument is simply abstruse as there is no clarity of thought and coherence in ideas and it also lack vision.  
 A) B) C) D)
- Q.22** The workers were raising much hue and cry when their demands were turned away.  
 A) B) C) D)
- Q.23** The disease is uncurable without the judicious use of antibiotics.  
 A) B) C) D)
- Q.24** The younger sister hopes to emulate her elder sister's sporting achievement as she is putting up hectic effort.  
 A) B) C) D)

## 2012

- Q.25** The theory was discarded as there was no corroborating evidence for its favour.  
 A) B) C) D)
- Q.26** The workers were raising much hue and cry when their demands were turned away.  
 A) B) C) D)
- Q.27** Aslam was badly cudgeled from his step-brother. He received many bruises and contusions. Thank God! No injury was serious.  
 A) B) C) D)
- Q.28** I extend a cordial invitation for you to visit our farm house. We have grown vegetables without chemical fertilizers over there.  
 A) B) C) D)

- Q.29** Although he is not a close relative of me, yet I was greeted with a show of deep cordiality.  
A) B) C) D)
- Q.30** This antibiotic destroys red corpuscles in the blood and cause pernicious anaemia.  
A) B) C) D)

## 2013

- Q.31** Amjad was not conscious to the aberration he had committed in the public meeting. It was disliked by all and sundry.  
A) B) C) D)
- Q.32** Late Agha Shahi was an outstanding genius in the international affairs. He was gifted of the acumen to judge the future events, judge the future events in advance.  
A) B) C) D)
- Q.33** The old man was sitting quite bamboozled when the swindler deprived him from his pension money by his evil tricks.  
A) B) C) D)
- Q.34** The prime minister fired a broadside at the opposition leaders. A few of his remarks were not up at the mark.  
A) B) C) D)
- Q.35** Lucy is the diva which performance as an opera singer is peerless.  
A) B) C) D)
- Q.36** The police report exonerated Anwar of all charges of corruption and job was also restored.  
A) B) C) D)

## 2014

- Q.37** We were ten miles up the highway when I happened to saw this classified advertisement in the newspaper.  
A) B) C) D)
- Q.38** "All is well what ends well", said the father when he had finished the story.  
A) B) C) D)
- Q.39** Rubber tubes upon which children had swing in backyards hung suspended like stopped clock pendulums in the blazing air.  
A) B) C) D)
- Q.40** The child was fully dressed and sitting in her father's lap near the kitchen table.  
A) B) C) D)
- Q.41** The three Abdal Rahman, like his illustrious predecessor, was a young man of twenty-three when he took office.  
A) B) C) D)
- Q.42** Enlarged and beautified by later Caliphs, Al-Zahra become the nucleus of a royal suburb whose remain partly evacuated in and after 1910, can still be seen.  
A) B) C) D)

## 2015

- Q.43 He picked up one or two magazines and after a hurried glance on the contents carefully replaced them.  
A) B) C) D)
- Q.44 His guests found it fun to watch him to make tea – mixing careful spoonful from different caddies.  
A) B) C) D)
- Q.45 You have put your life in his hands many a times.  
A) B) C) D)
- Q.46 Chips, thinking it over a good many time, always added to himself that Kathie would have approved and also have been amused.  
A) B) C) D)
- Q.47 But the men ate their supper in good appetites.  
A) B) C) D)
- Q.48 A common sense of failure is a mistaken ambition of the boys on the part of his parents.  
A) B) C) D)

## 2016

- Q.49 It showed that he was a man capable of looking beneath the surface of things, a man not dependent in paper manifestations.  
A) B) C) D)
- Q.50 When he was a child, every time he were naughty, his foster-mother used to threaten to send him to Timbuktu.  
A) B) C) D)
- Q.51 I was faced with alternatively of either evicting the books or else leaving them in sole, undisturbed tenancy and taking rooms elsewhere for myself.  
A) B) C) D)
- Q.52 I remember going to the British museum one day to read for the treatment for some slight ailment of which I had a touch-hay fever, I fancy it was.  
A) B) C) D)
- Q.53 The number of people in the world are rapidly increasing rather like a gigantic snowball which not only gets bigger as it rolls but goes faster as well.  
A) B) C) D)
- Q.54 It has been calculated that unless the growth is checked, there will only be enough room on the earth for people to stand by.  
A) B) C) D)

<b>ANSWERS</b>	<b>Q.1</b>	D	<b>Q.15</b>	C	<b>Q.29</b>	A	<b>Q.43</b>	C
	<b>Q.2</b>	A	<b>Q.16</b>	A	<b>Q.30</b>	D	<b>Q.44</b>	C
	<b>Q.3</b>	A	<b>Q.17</b>	A	<b>Q.31</b>	A	<b>Q.45</b>	C
	<b>Q.4</b>	B	<b>Q.18</b>	D	<b>Q.32</b>	B	<b>Q.46</b>	A
	<b>Q.5</b>	D	<b>Q.19</b>	D	<b>Q.33</b>	B	<b>Q.47</b>	D
	<b>Q.6</b>	D	<b>Q.20</b>	A	<b>Q.34</b>	D	<b>Q.48</b>	D
	<b>Q.7</b>	A	<b>Q.21</b>	D	<b>Q.35</b>	A	<b>Q.49</b>	D
	<b>Q.8</b>	C	<b>Q.22</b>	D	<b>Q.36</b>	A	<b>Q.50</b>	B
	<b>Q.9</b>	C	<b>Q.23</b>	A	<b>Q.37</b>	C	<b>Q.51</b>	A
	<b>Q.10</b>	B	<b>Q.24</b>	D	<b>Q.38</b>	A	<b>Q.52</b>	B
	<b>Q.11</b>	A	<b>Q.25</b>	D	<b>Q.39</b>	B	<b>Q.53</b>	A
	<b>Q.12</b>	B	<b>Q.26</b>	D	<b>Q.40</b>	C	<b>Q.54</b>	D
	<b>Q.13</b>	B	<b>Q.27</b>	A	<b>Q.41</b>	A		
	<b>Q.14</b>	D	<b>Q.28</b>	A	<b>Q.42</b>	C		



CHOOSE CORRECT SENTENCE



In each of the following question, four alternative sentences are given. Choose the CORRECT one and fill the Circle corresponding to that letter in the MCQ Response Form.

**2008**

**Q. 1**

- A) He lacked both the training and the equipment needed in the job.
- B) He lacked both the training and the equipment needed by the job.
- C) He lacked both the training and the equipment needed on the job.
- D) He lacked both the training and the equipment needed for the job.

**Q. 2**

- A) They tried to pacify him for kindness and affection.
- B) They tried to pacify him in kindness and affection.
- C) They tried to pacify him by kindness and affection.
- D) They tried to pacify him with kindness and affection.

**Q.3**

- A) Then he sat down in corner and remained quiet.
- B) Then he sat down in corner and remained quite.
- C) Then he sat down in corner and remain quiet.
- D) Then he sat down in corner and remained quiet.

**Q.4**

- A) He was drenched with the hotness of his fear.
- B) He was drenched in the hotness of his fear.
- C) He was drenched by the hotness of his fear.
- D) He was drenched off the hotness of his fear.

**Q.5**

- A) Why did you disagree with me?
- B) Why did you disagree to me?
- C) Why did you disagree on me?
- D) Why did you disagree by me?

**Q.6**

- A) Do not stuff your head by things you do not understand.
- B) Do not stuff your head with things you do not understand.
- C) Do not stuff your head for things you do not understand.
- D) Do not stuff your head in things you do not understand.

**Q.7**

- A) A day later he reached his first glimpse of Lahore.
- B) A day later he took his first glimpse of Lahore.
- C) A day later he found his first glimpse of Lahore.
- D) A day later he caught his first glimpse of Lahore.

**Q.8**

- A) This will have a bad impact to the economy.
- B) This will have a bad impact on the economy.
- C) This will have a bad impact at the economy.
- D) This will have a bad impact over the economy.

**Q.9**

- A) It would save him from dying of thirst.
- B) It would save him from dying from thirst.
- C) It would save him from dying with thirst.
- D) It would save him from dying by thirst.



Q.10

- A) All this flashed by his mind in an instant of protest.
- B) All this flashed on his mind in an instant of protest.
- C) All this flashed through his mind in an instant of protest.
- D) All this flashed by off mind in an instant of protest.

2009

Q.11

- A) E-mail is a relatively new mean of communication.
- B) E-mail is a relatively new mean to communication.
- C) E-mail is a relatively new means of communication.
- D) E-mail is a relatively new means to communication.

Q.12

- A) As she said the computer was programmed by Mona.
- B) Just like she said the computer was programmed by Mona.
- C) As like she said the computer was programmed by Mona.
- D) Just like she had she said the computer was programmed by Mona.

Q.13

- A) The remains of the body were thrown into the sea.
- B) The remain of the body was thrown into the sea.
- C) The remains of the body were thrown to the sea.
- D) The remains of the body was thrown into the sea.

Q.14

- A) We will discuss your problem as soon as the committee will leave.
- B) We will discuss your problem as soon as the committee left.
- C) We will discuss your problem as soon as the committee may leave.
- D) We will discuss your problem as soon as the committee leaves.

Q.15

- A) Reaching for the book, the ladder slipped out from under him.
- B) Reaching for the book, the ladder slipped out from him.
- C) When he reached for the book, the ladder was slipped out from under him.
- D) When he was trying to reach for the book, the ladder slipped from under him.

Q.16

- A) After the sun has set behind the mountain, a cool breeze sprang up and brought relief from the heat.
- B) After the sun had been set behind the mountain, a cool breeze sprang up and brought relief from the heat.
- C) After the sun would set behind the mountain, a cool breeze would sprang up and brought relief from the heat.
- D) After the sun set behind the mountain, a cool breeze sprang up and brought relief from the heat.

Q.17

- A) Masood told me that he would hire more salesman if he is in my position.
- B) Masood told me that he would hire more salesman if he has been in my position.
- C) Masood told me that he would hire more salesman if he has my position.
- D) Masood told me that he would hire more salesman if he had been in my position.

Q.18

- A) He consumed his heart on this and washed away before the very eyes of the people.
- B) He consumed his heart at this and washed away before the very eyes of the people
- C) He consumed his heart for this and washed away before the very eyes of the people.
- D) He consumed his heart over this and washed away before the very eyes of the people.

Q.19

- A) They felt bad while leaving their friends.
- B) They felt badly about leaving their friends.
- C) They felt very badly about leaving their friends.
- D) They felt badly while leaving their friends.

Q.20

- A) He then struck the man himself a similar bow, which felled him on the earth like a log.
- B) He then struck the man himself a similar bow, which felled him over the earth like a log.
- C) He then struck the man himself a similar bow, which felled him to the earth like a log.
- D) He then struck the man himself a similar bow, which felled him in the earth like a log.

## 2010

Q.21

- A) This is different to what had been expected.
- B) This is different what had been expected.
- C) This is different from what had been expected.
- D) This is different to what would be expected.

Q.22

- A) He suddenly remembered that he has left his house unlocked.
- B) He suddenly remembered that he may have left his house unlocked.
- C) He suddenly remembered that he had left his house unlocked.
- D) He suddenly remembered that he will have left his house unlocked.

Q.23

- A) He asked us would we care to go.
- B) He asked us if we would care to go.
- C) He asked us we would care to go.
- D) He asked us we will care to go.

Q.24

- A) When this war is over, no nation will either be isolated in war or peace.
- B) When this war is over, no nation will be either isolated in war or peace.
- C) When this war is over, no nation will neither be isolated in war nor peace.
- D) When this war is over, no nation will be isolated either in war or in peace.

Q.25

- A) When the fact failed him, he questions his senses.
- B) When the fact failed him, he questioned from his senses.
- C) When the fact fails him, he questions his senses.
- D) He will question his senses, when the fact will fail him.

Q.26

- A) He said there has been no need to do it.
- B) He said there wasn't no need to do it.
- C) He said there had been not any need doing it.
- D) He said there was no need to do it.

Q.27

- A) I could barely make of the traffic signs through the rain.
- B) I could barely make out the traffic signs because of the rain.
- C) I could barely make up the traffic signs through the rain.
- D) I could barely make with the traffic signs through the rain.

Q.28

- A) He walked as though he is lame.
- B) He walked as though he was lame.
- C) He walked as though he were lame.
- D) He walked as though he may have been lame.

Q.29

- A) E-mail is a relatively new means of communication.
- B) E-mail is a relatively new mean of communication.
- C) E-mail is a relatively new mean to communication.
- D) E-mail is a relatively new means to communication.

Q.30

- A) The remain of the body was thrown into the sea.
- B) The remains of the body were thrown into the sea.
- C) The remains of the body were thrown to the sea.
- D) The remains of the body was thrown into the sea.

## 2011

Q.31

- A) The government should accrue taxes for strengthen the economy of the country.
- B) The government should accrue taxes in strengthen the economy of the country.
- C) The government should accrue taxes to strengthen the economy of the country.
- D) The government should accrue taxes by strengthen the economy of the country.

Q.32

- A) Foreign trade have assumed greater importance in recent years.
- B) Foreign trade is assumed greater importance in recent years.
- C) Foreign trade has assumed greater importance in recent years.
- D) Foreign trade shall assumed greater importance in recent years.

Q.33

- A) The space programme has been battered in bureaucratic wrangling.
- B) The space programme has been battered into bureaucratic wrangling.
- C) The space programme has been battered by bureaucratic wrangling.
- D) The space programme has been battered to bureaucratic wrangling.

Q.34

- A) He will has to deal with the problem by showing adroitness.
- B) He will have to deal with the problem by showing adroitness.
- C) He will had to deal with the problem by showing adroitness.
- D) He will having to deal with the problem by showing adroitness.

Q.35

- A) He does possesses altruistic behavior.
- B) He does possess altruistic behavior.
- C) He does possessing altruistic behavior.
- D) He does possessed altruistic behavior.

Q.36

- A) He has great affinity in nature.
- B) He has great affinity with nature.
- C) He has great affinity by nature.
- D) He has great affinity at nature.

**Q.37**

- A) He stands on arms akimbo.
- B) He stands to arms akimbo.
- C) He stands with arms akimbo.
- D) He stands through arms akimbo.

**Q.38**

- A) An amorphous mass of cells are difficult to understand.
- B) An amorphous mass of cells were difficult to understand.
- C) An amorphous mass of cells had difficult to understand.
- D) An amorphous mass of cells is difficult to understand.

**Q.39**

- A) He is suffering to anaphylactic shock.
- B) He is suffering in anaphylactic shock.
- C) He is suffering from anaphylactic shock.
- D) He is suffering into anaphylactic shock.

**Q.40**

- A) If you had asked him, he would had accepted the offer with alacrity.
- B) If you had asked him, he would have being accepted the offer with alacrity.
- C) If you had asked him, he would have accepted the offer with alacrity.
- D) If you had asked him, he would been accepted the offer with alacrity.

**2012**

**Q.41**

- A) Why does not Nomana remained true to her husband?
- B) Why did not Nomana remain true to her husband?
- C) Why had not Nomana remain true to her husband?
- D) Why did not Nomana remained true to her husband?

**Q.42**

- A) All my childhood, I longed desperately in for a tricycle.
- B) All my childhood, I longed desperately to a tricycle.
- C) All my childhood, I longed desperately for a tricycle.
- D) All my childhood, I longed desperately at a tricycle.

**Q.43**

- A) She felt unreal to the voice informed her of the subway accident.
- B) She felt unreal as the voice informed her of the subway accident.
- C) She felt unreal that the voice informed her of the subway accident.
- D) She felt unreal for the voice informed her of the subway accident.

**Q.44**

- A) Bill Gates is one of the wealthiest person in the world.
- B) Bill Gates is one of the wealthy person in the world.
- C) Bill Gates is one of the wealthiest persons in the world.
- D) Bill Gates is one of the more wealthy person in the world.

**Q.45**

- A) Her father is a SP in the Punjab Police.
- B) Her father was a SP in the Punjab Police.
- C) Her father is an SP in the Punjab Police.
- D) Her father are a SP in the Punjab Police.

**Q.46**

- A) There were musical instruments in the shop.
- B) There was musical instruments in the shop.
- C) There has musical instruments in the shop.
- D) There is musical instruments in the shop.

**Q.47**

- A) He died for heart attack in 1982.
- B) He died with heart attack in 1982.
- C) He died in heart attack in 1982.
- D) He died of heart attack in 1982.

**Q.48**

- A) Always speak in the truth.
- B) Always tell for the truth.
- C) Always tell the truth.
- D) Always telling truth.

**Q.49**

- A) Hand up the answer sheet to me.
- B) Hand over the answer sheet to me.
- C) Hand down the answer sheet to me.
- D) Hand for the answer sheet to me.

**Q.50**

- A) Are you noticed the peach blossoms?
- B) Have you noticed the peach blossoms?
- C) Will you noticed the peach blossoms?
- D) Were you noticed the peach blossoms?

2013

**Q.51**

- A) We should pay maximum accolade for our national heroes.
- B) We should pay maximum accolade in our national heroes.
- C) We should pay maximum accolade to our national heroes.
- D) We should pay maximum accolade from our national heroes.

**Q.52**

- A) Does any bodys knows why the latitudes close to the equator are called the horse latitudes?
- B) Do any body knows why the latitudes close to the equator are called the horse latitudes?
- C) Does any body knows why the latitudes close to the equator are called the horse latitudes?
- D) Does any body know why the latitudes close to the equator are called the horse latitudes?

**Q.53**

- A) Shelley is consider to be an idealist poet.
- B) Shelley is considering to be an idealist poet.
- C) Shelley is considers to be an idealist poet.
- D) Shelley is considered to be an idealist poet.

**Q.54**

- A) Pakistan cricket team forged an impregnable lead.
- B) Pakistan cricket team forged the impregnable lead.
- C) Pakistan cricket team forged against impregnable lead.
- D) Pakistan cricket team forged on impregnable lead.

Q.55

- A) A person whose job involves calculating insurance risks and payments for insurance companies by studying how frequently fires, accidents, death etc. happen is called an actuary.
- B) A person whose job involves calculating insurance risks and payments for insurance companies by studying how frequently fires, accidents, death etc. happen is called an actuary.
- C) A person whose job involves calculating insurance risks and payments for insurance companies by studying how frequently fires, accidents, death etc. happen is called an actuary.
- D) A person whose job involves calculating insurance risks and payments for insurance companies by studying how frequently fires, accidents, death etc. happen are called an actuary.

Q.56

- A) His addled brain refused to think clearly and solve the problem.
- B) His addled brain refused to think clearly and solve the problem.
- C) His addled brain refused to think clearly and solve the problem.
- D) His addled brain refused to think clearly and solve the problem.

Q.57

- A) The children had bloomed while their stay on the farm.
- B) The children had bloomed during their stay on the farm.
- C) The children had bloomed on their stay on the farm.
- D) The children were bloomed while their stay on the farm.

Q.58

- A) I should have had business acumen.
- B) I should have had business acumen.
- C) I should have had business acumen.
- D) I should have had business acumen.

Q.59

- A) No one is casting aspersions on you.
- B) No one is casting aspersions at you.
- C) No one is casting aspersions on you.
- D) No one is casting aspersions with you.

Q.60

- A) This is one of the bifurcated roads.
- B) This is one of the bifurcated roads.
- C) This is one of the bifurcated roads.
- D) This is one off the bifurcated road.

2014

Q.61

- A) I thought it over very carefully before broaching the subject to Asma.
- B) I thought it on very carefully before broaching the subject to Asma.
- C) I thought it by very carefully before broaching the subject to Asma.
- D) I thought it upon very carefully before broaching the subject to Asma.

Q.62

- A) He left into a blaze of anger.
- B) He left with a blaze of anger.
- C) He left in a blaze of anger.
- D) He left back in a blaze of anger.

Q.63

- A) Shahid battered Anwar down submission.
- B) Shahid battered Anwar into submission.
- C) Shahid down battered Anwar into submission.
- D) Shahid was battered Anwar down submission.

**Q.64**

- A) Pride was an intrinsic component of his personal makeup.
- B) Pride was a intrinsic component of his personal makeup.
- C) Pride an intrinsic component of his personal makeup.
- D) Pride were an intrinsic component of his personal makeup.

**Q.65**

- A) The government introduced tax laws which gave incentives to factory workers to reduce pollution.
- B) The government introduced tax laws who gave incentives to factory workers to reduce pollution.
- C) The government introduced tax laws which have incentives to factory workers to reduce pollution.
- D) The government introduced tax laws which has incentives to factory workers to reduce pollution.

**Q.66**

- A) It was cold and foggy, and he dared not to going out.
- B) It was cold and foggy, and he dared not for going out.
- C) It was cold and foggy, and he dared not go out.
- D) It was cold and foggy, and he dared not gone out.

**Q.67**

- A) There was much cheering and singing and a bread fighting across the dining hall.
- B) There was much cheering and singing and a bread fight across the dining hall.
- C) There was more cheer and singing and a bread fighting across the dining hall.
- D) There was much cheer and singing and a bread fighting across the dining hall.

**Q.68**

- A) Both parents of Jameel were then long died.
- B) Both parents of Jameel were then long dead.
- C) Both parents of Jameel were by then long dead.
- D) Both parents of Jameel were by then long died.

**Q.69**

- A) But the men ate their supper with good appetites.
- B) But the men ate their supper in good appetites.
- C) But the men ate their supper for good appetites.
- D) But the men ate their supper into good appetites.

**Q.70**

- A) The boy was afraid of going to jail.
- B) The boy was afraid off going to jail.
- C) The boy was afraid on going to jail.
- D) The boy was afraid by going to jail.

**2015**

**Q.71**

- A) Tourism is burgeoned over the last fifteen years.
- B) Tourism will burgeoned over the last fifteen years.
- C) Tourism have burgeoned over the last fifteen years.
- D) Tourism has burgeoned over the last fifteen years.

**Q.72**

- A) His remains were interred in the new cemetery.
- B) His remains were entered in the new cemetery.
- C) His remains was interred in the new cemetery.
- D) His remains was entered in the new cemetery.

Q.73

- A) They had died in the same day.
- B) They had died over the same day.
- C) They had died on the same day.
- D) They had died of the same day.

Q.74

- A) She had turned on the supper steaks when the telephone rang.
- B) She had turned over the supper steaks when the telephone rang.
- C) She had turned into the supper steaks when the telephone rang.
- D) She had turned in the supper steaks when the telephone rang.

Q.75

- A) Empty of concord is the soul of wit.
- B) Empty of concord is the role of wit.
- C) Empty of concord is the sole of wit.
- D) Empty of concord is the howl of wit.

Q.76

- A) The cheery trees stand over the woodland ride.
- B) The cheery trees stand about the woodland ride.
- C) The cheery trees stand beside the woodland ride.
- D) The cheery trees stand on the woodland ride.

Q.77

- A) He made me to write the sum on the slip and to sign my name in a book.
- B) He made me write the sum on/at the slip and to sign my name in a book.
- C) He made me to write the sum on the slip and sign my name in a book.
- D) He made me to write the sum in a slip and to sign my name in a book.

Q.78

- A) I am looking forward to secure excellent marks in MCAT.
- B) I am looking forward to securing excellent marks in MCAT.
- C) I am looking forward securing excellent marks in MCAT.
- D) I am looking forward secure excellent marks in MCAT.

Q.79

- A) The study of population growth indicates one of the greatest paradox of our time.
- B) The study of population growth indicate one of the greatest paradox of our time.
- C) The study of population growth indicates one of the greatest paradoxes of our time.
- D) The study of population growth indicates one of the greatest paradox in our time.

Q.80

- A) In North Africa, he barely escaped assassination at the hand of the governor of the province.
- B) In North Africa, he barely escaped from assassination at the hands of the governor of the province.
- C) In North Africa, he barely escaped from assassination at the hand of the governor of the province.
- D) In North Africa, he barely escaped assassination at the hands of the governor of the province.

**2016**

Q.81

- A) Inside a carton was a push-button unit fastened with a small wooden box.
- B) Inside a carton was a push-button unit fastened by a small wooden box.
- C) Inside a carton was a push-button unit fastened to a small wooden box.
- D) Inside a carton was a push-button unit fastened along a small wooden box.



**Q.82**

- A) They both looked to one another, startled by all they had just finished saying.
- B) They both looked to each another, startled by all they had just finish saying.
- C) They both looked to each another, startle by all they had just finish saying.
- D) They both looked to each another, startled by all they had just finished saying.

**Q.83**

- A) The lovely sentiments we go through repeating!
- B) The lovely sentiments we go about repeating!
- C) The lovely sentiments we go in repeating!
- D) The lovely sentiments we go for repeating!

**Q.84**

- A) With the bright light, still in her eyes, she moved quick out of the door.
- B) With the bright light, still in her eyes, she moved quick out to the door.
- C) With the bright light, still in her eyes, she moved quickly out to the door.
- D) With the bright light, still in her eyes, she moved quickly out of the door.

**Q.85**

- A) In a short while quiet a large crowd had been collected.
- B) In a short while quite a large crowd had collected.
- C) In a short while quite large crowd had collected.
- D) In a short while quite the large crowd had been collecting.

**Q.86**

- A) She watched all the important matches in the Brookfield ground.
- B) She watched all the important matches on the Brookfield ground.
- C) She watched all the important matches from the Brookfield ground.
- D) She watched all the important matches within the Brookfield ground.

**Q.87**

- A) Something had happened, something whose ultimate significance had yet to be reckon.
- B) Something had happened, something whose ultimate significance had yet was reckon.
- C) Something had happened, something whose ultimate significance had yet to be reckoned.
- D) Something had happened, something whose ultimate significance had yet reckoned.

**Q.88**

- A) His faculties were all unimpairment, and he had no personal worries of any kind.
- B) His faculties were all unimparing, and he had no personal worries of any kind.
- C) His faculties were all unimpaired, and he had no personal worry of any kind.
- D) His faculties were all unimpaired, and he had no personal worries of any kind.

**Q.89**

- A) It was hard to him to speak out loud, but he managed to murmur something.
- B) It was hard on him to speak out loud, but he managed to murmur something.
- C) It was hard for him to speak out loud, but he managed to murmur something.
- D) It was hard upon him to speak out loud, but he managed to murmur something.

**Q.90**

- A) There was a little money saved up beside.
- B) There was little money saved in besides.
- C) There was little money saved up beside.
- D) There was a little money saved up besides.

## ANSWERS

Q.1	D	Q.24	D	Q.47	D	Q.70	A
Q.2	D	Q.25	C	Q.48	C	Q.71	D
Q.3	D	Q.26	D	Q.49	B	Q.72	A
Q.4	B	Q.27	B	Q.50	B	Q.73	C
Q.5	A	Q.28	B	Q.51	C	Q.74	B
Q.6	B	Q.29	A	Q.52	D	Q.75	A
Q.7	D	Q.30	B	Q.53	D	Q.76	B
Q.8	B	Q.31	C	Q.54	D	Q.77	C
Q.9	A	Q.32	C	Q.55	C	Q.78	B
Q.10	C	Q.33	C	Q.56	D	Q.79	C
Q.11	C	Q.34	B	Q.57	B	Q.80	B
Q.12	A	Q.35	B	Q.58	B	Q.81	C
Q.13	A	Q.36	B	Q.59	C	Q.82	D
Q.14	D	Q.37	C	Q.60	B	Q.83	B
Q.15	D	Q.38	D	Q.61	A	Q.84	D
Q.16	D	Q.39	C	Q.62	C	Q.85	B
Q.17	D	Q.40	C	Q.63	B	Q.86	B
Q.18	D	Q.41	B	Q.64	A	Q.87	C
Q.19	A	Q.42	C	Q.65	A	Q.88	D
Q.20	C	Q.43	B	Q.66	C	Q.89	C
Q.21	C	Q.44	C	Q.67	B	Q.90	D
Q.22	C	Q.45	C	Q.68	C		
Q.23	B	Q.46	A	Q.69	A		



# VOCABULARY



In each of the following question, four alternative meanings of a word are given. You have to select the **NEAREST CORRECT MEANING** of the given word and fill the appropriate Circle on the MCQ Response Form.

## 2008

- Q.1 VEXING**  
 A) Annoying.  
 B) Aggressive.  
 C) Viable.  
 D) Waxy.
- Q.2 VAGUE**  
 A) Respectful.  
 B) Uncertain.  
 C) Warlock.  
 D) Snow white.
- Q.3 MANGLED**  
 A) Dodged.  
 B) Grained.  
 C) Indisputable.  
 D) Damaged.
- Q.4 PRODIGIOUS**  
 A) Productive.  
 B) Enormous.  
 C) Prudential.  
 D) Waddle.
- Q.5 ASTOUNDED**  
 A) Shocked.  
 B) Discarded.  
 C) Assured.  
 D) Attracted.
- Q.6 SAGACITY**  
 A) Foolishness.  
 B) Large City.  
 C) Onions.  
 D) Wisdom.
- Q.7 GRIM**  
 A) Gratis.  
 B) Restless.  
 C) Severe.  
 D) Grater.
- Q.8 INDOLENTLY**  
 A) Lazily.  
 B) Indecently.  
 C) Ideally.  
 D) Gaily.
- Q.9 PERISH**  
 A) Furious.  
 B) Come to death.  
 C) Secret.  
 D) Frustrated.
- Q.10 DOZE**  
 A) Dogged.  
 B) Diet.  
 C) Sleep.  
 D) Medicine to be taken.

## 2009

- Q.11 AGHAST**  
 A) Critical  
 B) Reluctant  
 C) Happy  
 D) Horrified
- Q.12 INVIDIOUS**  
 A) Unbreakable  
 B) Interesting  
 C) Unpleasant  
 D) Fair

- Q.13 IMPROMPTU**  
 A) Arriving at the right time  
 B) Showing signs of being good  
 C) Done without preparation  
 D) Wretched
- Q.14 DISCERNMENT**  
 A) A system of controlling a country  
 B) The ability to show good judgement  
 C) The act of encouraging somebody  
 D) The ability to show no concern
- Q.15 NEOLOGISM**  
 A) A new word  
 B) Pleasant remark  
 C) Brief summary  
 D) Archaic expression
- Q.16 FURTIVE**  
 A) Furious  
 B) Familiar  
 C) Secretive  
 D) Easy
- Q.17 BOURGEOIS**  
 A) Belonging to the bureaucratic class  
 B) Belonging to the middle class  
 C) Belonging to the upper class  
 D) Belonging to the lower class
- Q.18 RUMINATE**  
 A) Eat greedily  
 B) Think deeply  
 C) Work lazily  
 D) Run fast
- Q.19 EMBELLISH**  
 A) Beautify  
 B) Nominate  
 C) Finish  
 D) Weaken
- Q.20 PARABLE**  
 A) Impossible  
 B) Sociable  
 C) Allegory  
 D) Suitable

 2010

- Q.21 WALLOW**  
 A) Roll about  
 B) Mock  
 C) Protest  
 D) Borrow
- Q.22 CONNOISSEUR**  
 A) Guide  
 B) Artist  
 C) Expert critic of art  
 D) Teacher
- Q.23 ECCENTRIC**  
 A) Lunatic  
 B) Stern  
 C) Upset  
 D) Odd
- Q.24 BOULDER**  
 A) Rounded stone / hill  
 B) Builder  
 C) Magnanimity  
 D) Magnitude
- Q.25 SLUMBER**  
 A) Heap  
 B) Humble  
 C) Knee  
 D) Sleep
- Q.26 EXCREMENT**  
 A) Increment  
 B) Waste matter expelled from body  
 C) Excitement  
 D) Disagreement

- Q.27 VISAGE**  
 A) Vision  
 B) Illusion  
 C) Trunk less  
 D) A person's face
- Q.28 FELICITY**  
 A) Intense Happiness  
 B) Respite  
 C) Inspire  
 D) Sensational
- Q.29 ENMESHED**  
 A) Sojourn  
 B) Entangled  
 C) Gallows  
 D) Cascade
- Q.30 CAPTIVATE**  
 A) Hesitate  
 B) Concentrate  
 C) Hate  
 D) Fascinate

## 2011

- Q.31 MUSE**  
 A) Wander  
 B) Fonder  
 C) Robust  
 D) Ponder
- Q.32 FECKLESS**  
 A) Useless  
 B) Careless  
 C) Dauntless  
 D) Fearless
- Q.33 MOSAIC**  
 A) Pattern  
 B) Mortal  
 C) Ordinary  
 D) Musical
- Q.34 INSCRUTABLE**  
 A) Immoral  
 B) Unethical  
 C) Enigmatic  
 D) Unaccountable
- Q.35 JUXTAPOSE**  
 A) Justify  
 B) Compare  
 C) Expose  
 D) Jettison
- Q.36 LACERATING**  
 A) Landing  
 B) Tearing  
 C) Flagging  
 D) Lactating
- Q.37 EMPATHY**  
 A) Fictitious  
 B) Facility  
 C) Ability  
 D) Felicity
- Q.38 EVANESCENT**  
 A) Evident  
 B) Permanent  
 C) Event  
 D) transitory
- Q.39 SIDLE**  
 A) Sneak  
 B) Sift  
 C) Sledge  
 D) Sieve
- Q.40 DISSONANCE**  
 A) Inconsistency  
 B) Expansion  
 C) Perceptible  
 D) WrapPart

## 2012

- Q.41 DISSONANCE**  
 A) Inconsistency  
 B) Expansion  
 C) Perceptible  
 D) Warp
- Q.42 TRIFLE**  
 A) Pudding  
 B) Minor  
 C) Deluge  
 D) Treble
- Q.43 MURKY**  
 A) Dusty  
 B) Squeamy  
 C) Clear  
 D) Unclear
- Q.44 FAUX**  
 A) Blunder  
 B) Mistake  
 C) Indiscretion  
 D) False
- Q.45 MYRIAD**  
 A) Countable  
 B) Multitude  
 C) Measured  
 D) Blurred
- Q.46 FACILE**  
 A) Fallacy  
 B) Depict  
 C) Delicate  
 D) Superficial
- Q.47 MAGNUM**  
 A) Masterpiece  
 B) Magnanimity  
 C) Modest  
 D) Magnetic
- Q.48 SIDLE**  
 A) Sneak  
 B) Sift  
 C) Siege  
 D) Sieve
- Q.49 PLETHORA**  
 A) Plastic  
 B) Super-fluidity  
 C) Measure  
 D) Malleable
- Q.50 VERTEX**  
 A) Poetry  
 B) Depth  
 C) Zenith  
 D) Diminish

## 2013

- Q.51 HEINOUS**  
 A) Heroic  
 B) Humorous  
 C) Odious  
 D) Hone
- Q.52 ILLICIT**  
 A) Intimate  
 B) Licentious  
 C) Illegal  
 D) Limited
- Q.53 MOTIF**  
 A) Tough  
 B) Stuff  
 C) Motion  
 D) Design

- Q.54 INCULCATE**  
 A) Calculate  
 B) Instill  
 C) Instigate  
 D) Stimulate
- Q.55 INIQUITY**  
 A) Inequality  
 B) Injustice  
 C) Wickedness  
 D) Efficiency
- Q.56 INTRANSIGENT**  
 A) Parallel  
 B) Inflexible  
 C) Adventurous  
 D) Spirited
- Q.57 LAMPOON**  
 A) Irk  
 B) Gratification  
 C) Lacerate  
 D) Ridicule
- Q.58 MESMERIZE**  
 A) Objectify  
 B) Modify  
 C) Amalgamate  
 D) Fascinate
- Q.59 OBLITERATE**  
 A) Sanctify  
 B) Obscure  
 C) Annihilate  
 D) Oplate
- Q.60 MALEVOLENCE**  
 A) Empathy  
 B) Maligning  
 C) Hostility  
 D) Management
- 
- 2014**
- Q.61 DISDAIN**  
 A) Vice  
 B) Dislike  
 C) Contempt  
 D) Ignorance
- Q.62 SAGACITY**  
 A) Suspicious  
 B) Cruelty  
 C) Wisdom  
 D) Foolishness
- Q.63 FLAUNT**  
 A) Snipe  
 B) Dance  
 C) Show off  
 D) Preserve
- Q.64 URBANE**  
 A) Suave  
 B) Rough  
 C) Bad  
 D) Dishonest
- Q.65 DIASPORA**  
 A) Gathering  
 B) Dispersion  
 C) Alliance  
 D) Animosity
- Q.66 IMPETUOUS**  
 A) Honest  
 B) Impulsive  
 C) Lazy  
 D) Liar
- Q.67 VOCIFEROUS**  
 A) Hidden  
 B) Loud  
 C) Strong  
 D) Weak



- Q.68 TRANSIENT**  
 A) Permanent  
 B) Temporary  
 C) Long  
 D) Good
- Q.69 PROWESS**  
 A) Hindrance  
 B) Skill  
 C) Reservation  
 D) Bad name
- Q.70 BEQUEATH**  
 A) Grant  
 B) Imbibe  
 C) Irrigate  
 D) Hope

## 2015

- Q.71 EMPATHY**  
 A) Understanding  
 B) Animosity  
 C) Friendship  
 D) Sympathy
- Q.72 FELICITY**  
 A) Boredom  
 B) Business  
 C) Happiness  
 D) Relaxation
- Q.73 UNCANNY**  
 A) Exact  
 B) Opposite  
 C) Good  
 D) Strange
- Q.74 VIRULENT**  
 A) Progressive  
 B) Harmful  
 C) Healthy  
 D) Positive
- Q.75 RAPT**  
 A) Trumpet  
 B) Bewitched  
 C) Rapid  
 D) Rash
- Q.76 PEDAGOGY**  
 A) The study of pediatrics  
 B) The study of teaching methods  
 C) The study of cultural heritage  
 D) The study of pectoral muscle
- Q.77 INDICTMENT**  
 A) Humiliation  
 B) Offended  
 C) Accusation  
 D) Invisible
- Q.78 MITIGATION**  
 A) Alleviation  
 B) Classification  
 C) Formidable  
 D) Poisonous
- Q.79 CONCERTED**  
 A) Strenuous  
 B) Furious  
 C) Curious  
 D) Precious
- Q.80 ARCANE**  
 A) Mysterious  
 B) Furious  
 C) Arid  
 D) Clear

## 2016

- Q.81 STALWART**  
A) Loyal  
B) Lazy  
C) Lacking strength  
D) High
- Q.82 CHIVALRY**  
A) Coward  
B) Non-cooperative  
C) Imitating  
D) Gallant
- Q.83 RAKISH**  
A) Curved  
B) Traditional  
C) Formal  
D) Dashing
- Q.84 PRODIGIOUS**  
A) Huge  
B) Trivial  
C) Little  
D) Square
- Q.85 IMPROVISE**  
A) Colophon  
B) Concoct  
C) Divert  
D) Respite
- Q.86 PARADOX**  
A) Anomaly  
B) Prototype  
C) Steward  
D) Fashion
- Q.87 MANIFESTATION**  
A) Mode  
B) Token  
C) Quirk  
D) Bulwark
- Q.88 RECONNOITRE**  
A) Patrol  
B) Arcane  
C) Exhort  
D) Falter
- Q.89 SOJOURN**  
A) Visit  
B) Belch  
C) Furry  
D) Inking
- Q.90 MUSE**  
A) Immaculate  
B) Chew over  
C) Sigh over  
D) Vagary

<b>ANSWERS</b>	<b>Q.1</b>	A	<b>Q.24</b>	A	<b>Q.47</b>	A	<b>Q.70</b>	A
	<b>Q.2</b>	B	<b>Q.25</b>	D	<b>Q.48</b>	A	<b>Q.71</b>	D
	<b>Q.3</b>	D	<b>Q.26</b>	B	<b>Q.49</b>	B	<b>Q.72</b>	C
	<b>Q.4</b>	B	<b>Q.27</b>	D	<b>Q.50</b>	C	<b>Q.73</b>	D
	<b>Q.5</b>	A	<b>Q.28</b>	A	<b>Q.51</b>	C	<b>Q.74</b>	B
	<b>Q.6</b>	D	<b>Q.29</b>	B	<b>Q.52</b>	B	<b>Q.75</b>	B
	<b>Q.7</b>	C	<b>Q.30</b>	D	<b>Q.53</b>	D	<b>Q.76</b>	B
	<b>Q.8</b>	A	<b>Q.31</b>	D	<b>Q.54</b>	B	<b>Q.77</b>	C
	<b>Q.9</b>	B	<b>Q.32</b>	A	<b>Q.55</b>	C	<b>Q.78</b>	A
	<b>Q.10</b>	C	<b>Q.33</b>	A	<b>Q.56</b>	B	<b>Q.79</b>	A
	<b>Q.11</b>	D	<b>Q.34</b>	C	<b>Q.57</b>	D	<b>Q.80</b>	A
	<b>Q.12</b>	C	<b>Q.35</b>	B	<b>Q.58</b>	D	<b>Q.81</b>	A
	<b>Q.13</b>	C	<b>Q.36</b>	B	<b>Q.59</b>	C	<b>Q.82</b>	D
	<b>Q.14</b>	B	<b>Q.37</b>	C	<b>Q.60</b>	C	<b>Q.83</b>	D
	<b>Q.15</b>	A	<b>Q.38</b>	D	<b>Q.61</b>	C	<b>Q.84</b>	A
	<b>Q.16</b>	C	<b>Q.39</b>	A	<b>Q.62</b>	C	<b>Q.85</b>	B
	<b>Q.17</b>	B	<b>Q.40</b>	A	<b>Q.63</b>	C	<b>Q.86</b>	A
	<b>Q.18</b>	B	<b>Q.41</b>	A	<b>Q.64</b>	A	<b>Q.87</b>	B
	<b>Q.19</b>	A	<b>Q.42</b>	B	<b>Q.65</b>	B	<b>Q.88</b>	A
	<b>Q.20</b>	D	<b>Q.43</b>	D	<b>Q.66</b>	B	<b>Q.89</b>	A
	<b>Q.21</b>	A	<b>Q.44</b>	D	<b>Q.67</b>	B	<b>Q.90</b>	B
	<b>Q.22</b>	C	<b>Q.45</b>	B	<b>Q.68</b>	B		
	<b>Q.23</b>	D	<b>Q.46</b>	D	<b>Q.69</b>	B		

2011-2016

# MEDICAL COLLEGE APTITUDE TEST - BIOLOGY

UHS, LAHORE

PAST PAPERS UNIT WISE MCQs

Ali Raza

ARK



# Table of Specification



NO.	UNIT NAME	MCQs
1.	INTRODUCTION TO BIOLOGY	1
2.	CELL BIOLOGY	10
3.	BIOLOGICAL MOLECULES	
a)	CARBOHYDRATES	2
b)	PROTEINS	1
c)	LIPIDS	1
d)	NUCLEIC ACIDS	1
e)	ENZYMES	4
4.	MICROBIOLOGY	
a)	VIRUS	1
b)	BACTERIA	2
c)	FUNGI	1
5.	KINGDOM ANIMALIA	5
6.	HUMAN PHYSIOLOGY	
a)	DIGESTIVE SYSTEM	5
b)	GAS EXCHANGE AND TRANSPORTATION	5
c)	EXCRETION AND OSMOREGULATION	6
d)	NERVOUS SYSTEM	4
e)	REPRODUCTION	5
f)	SUPPORT AND MOVEMENT	5
g)	HORMONAL CONTROL (ENDOCRINE GLANDS)	4
h)	IMMUNITY	5
7.	BIOENERGETICS	5
8.	BIOTECHNOLOGY	5
9.	ECOSYSTEM	5
10.	EVOLUTION AND GENETICS	5
<b>TOTAL:</b>		<b>88</b>



# Contents

NO.	UNIT NAME	PAGE NO.
1.	INTRODUCTION TO BIOLOGY	4
2.	CELL BIOLOGY	6
3.	BIOLOGICAL MOLECULES	12
4.	MICROBIOLOGY	18
5.	KINGDOM ANIMALIA	21
6.	HUMAN PHYSIOLOGY	24
a)	DIGESTIVE SYSTEM	25
b)	GAS EXCHANGE AND TRANSPORTATION	28
c)	EXCRETION AND OSMOREGULATION	31
d)	NERVOUS SYSTEM	34
e)	REPRODUCTION	37
f)	SUPPORT AND MOVEMENT	40
g)	HORMONAL CONTROL (ENDOCRINE GLANDS)	43
h)	IMMUNITY	46
7.	BIOENERGETICS	49
8.	BIOTECHNOLOGY	52
9.	ECOSYSTEM	55
10.	EVOLUTION AND GENETICS	59

## 1

## INTRODUCTION TO BIOLOGY

## 2011

- Q.1 Which of the following diseases can be prevented through vaccination?**  
 A) AIDS and Cancer  
 B) Malaria and AIDS  
 C) Typhoid and Cancer  
 D) Measles and Mumps
- Q.2 Newly produced cells/individuals which are identical in each other are known as**  
 A) Genetically Modified  
 B) Transgenic Animals  
 C) Transgenic Bacteria  
 D) Clones
- Q.3 Which of the following is a blood borne disease?**  
 A) Hepatitis  
 B) Cholera  
 C) Influenza  
 D) Candidiasis
- Q.4 The control of pest has traditionally meant regulation by natural enemies, predators, parasites and pathogens. This type of control is known as**  
 A) Cultural Control  
 B) Biological Control  
 C) Pesticides Control  
 D) Insecticides Control

## 2012

- Q.5 Population of different species (plants and animals) living in the same habitat form a**  
 A) Community  
 B) Ecosystem  
 C) Biosphere  
 D) Microhabitat
- Q.6 The part of the body which forms a structural and functional unit and is composed of more than one tissue is called**  
 A) Organ  
 B) Organelle  
 C) Organ system  
 D) Whole organism
- Q.7 A method in which pests are destroyed by using same living organisms or natural enemies is called**  
 A) Pasteurization  
 B) Integrated disease management  
 C) Biological control  
 D) Genetic engineering
- Q.8 Chemicals produced by microorganisms which are capable of destroying the growth of microbes are called**  
 A) Antigen  
 B) Biocidal  
 C) Antiseptics  
 D) Antibiotics

## 2013

- Q.9 The simplest independent unit of life is known as:**  
 A) Bacterial colony  
 B) Cell  
 C) Chloroplast  
 D) DNA

- Q.10 The plants having foreign DNA incorporated into their cells are called:**  
 A) Clonal plants  
 B) Transgenic plants  
 C) Biotech plants  
 D) Tissue cultured plants
- Q.11 Pasteurization technique is widely used for preservation of:**  
 A) Water  
 B) Heat  
 C) Milk products  
 D) Vaccines
- Q.12 The production of genetically identical copies of organisms by asexual reproduction is called:**  
 A) Genetic engineering  
 B) Integrated disease management  
 C) Hydroponic culture technique  
 D) Cloning

**2014**

- Q.13 The use of living organisms in industry for the production of useful products is known as**  
 A) Parasitology  
 B) Biochemistry  
 C) Biotechnology  
 D) Molecular Biology
- Q.14 Plants having foreign DNA incorporated into their cells are called:**  
 A) Clone plants  
 B) Transgenic plants  
 C) Parthenocarpic plants  
 D) Mutant giants
- Q.15 Treatment by using attenuated culture of bacteria is called**  
 A) Chemotherapy  
 B) Sterilization  
 C) Antisepsis  
 D) Vaccination
- Q.16 The major cause of hepatitis B is**  
 A) Blood transfusion  
 B) Blood clotting  
 C) Absence of fibrinogen  
 D) Contaminated soil

**2015**

- Q.17 Which one of the following edible products is widely pasteurized?**  
 A) Soft drinks  
 B) Mango squash  
 C) Milk  
 D) Orange Juice

**2016**

- Q.18 \_\_\_\_\_ is the branch of Biology used for the identification and interpretation of fossils.**  
 A) Evolution  
 B) Paleontology  
 C) Zoogeography  
 D) Biodiversity

<b>ANSWERS</b>	<b>Q.1</b>	D	<b>Q.7</b>	C	<b>Q.13</b>	C
	<b>Q.2</b>	A	<b>Q.8</b>	D	<b>Q.14</b>	B
	<b>Q.3</b>	A	<b>Q.9</b>	B	<b>Q.15</b>	D
	<b>Q.4</b>	B	<b>Q.10</b>	B	<b>Q.16</b>	A
	<b>Q.5</b>	A	<b>Q.11</b>	C	<b>Q.17</b>	C
	<b>Q.6</b>	A	<b>Q.12</b>	D	<b>Q.18</b>	B



## 2

## CELL BIOLOGY

## 2011

- Q.1** When chromosomes uncoil, the nucleoli are reformed and two nuclei are the two poles of the cell; stage is known as  
 A) Prophase  
 B) Metaphase  
 C) Telophase  
 D) Anaphase
- Q.2** Mental retardation, short stature, broad face and squint eyes are the symptoms of  
 A) Down's syndrome  
 B) Klinefelter's syndrome  
 C) Turner's syndrome  
 D) XYZ syndrome
- Q.3** Chiasmata formation takes place during the process which is known as  
 A) Crossing Over  
 B) Attachment  
 C) Pairing  
 D) Leptotene
- Q.4** Healing of a wound and repair is the phenomenon which takes place by the process of  
 A) Mitosis  
 B) Meiosis  
 C) Cell Growth  
 D) Mitosis & Meiosis
- Q.5** Which one of the following is the main cause of cancer?  
 A) Mutation  
 B) Controlled Cell Division  
 C) Regulated Mitosis  
 D) Haploid Division
- Q.6** Which of the following organelles is concerned with the cell secretion  
 A) Ribosomes  
 B) Golgi Apparatus  
 C) Lysosomes  
 D) Mitochondria
- Q.7** Which of the following contains peptidoglycan cell wall?  
 A) Penicillium  
 B) Bacterium  
 C) Adiantum  
 D) Polytrichum
- Q.8** The inner membrane of mitochondria is folded to form finger like structure called  
 A) Cristae  
 B) Vesicle  
 C) Matrix  
 D) Cisternae
- Q.9** Interior of chloroplast is divided into heterogeneous structure, embedded in the matrix known as  
 A) Grana  
 B) Stroma  
 C) Thylakoids  
 D) Cisternae
- Q.10** In which phase of the cell division the metabolic activity of the nucleus is high?  
 A) Mitosis  
 B) Interphase  
 C) Meiosis  
 D) Cell Cycle

## 2012

- Q.11** Plastids are only found in the  
 A) Animals and Plants  
 B) Animals  
 C) Plants  
 D) Viruses

- Q.12 Plasma membrane is chemically composed of**  
 A) Phospholipids only  
 B) Lipids and proteins  
 C) Lipids and carbohydrates  
 D) Glycoproteins
- Q.13 Endoplasmic reticulum contains a system of flattened membrane-bounded sacs which are named as**  
 A) Cristae  
 B) Marks  
 C) Cisternae  
 D) Tubules
- Q.14 Lipids synthesis / metabolism takes place in which of the following organelle?**  
 A) Mitochondria  
 B) Vacuoles  
 C) Rough endoplasmic reticulum  
 D) Smooth endoplasmic reticulum
- Q.15 Ribosomes exist in two forms, either attached with RER or freely dispersed in the**  
 A) Tonoplast  
 B) Golgi bodies  
 C) Cytoplasm  
 D) SER
- Q.16 Exchange of segments between homologous chromosomes is called**  
 A) Segregation  
 B) Independent assortment  
 C) Crossing over  
 D) Mutation
- Q.17 If a person has 44 autosomes + XXY, he will suffer from**  
 A) Klinefelter's syndrome  
 B) Down's syndrome  
 C) Turner's syndrome  
 D) Edward's syndrome
- Q.18 The ribosomal RNA is synthesized and stored in**  
 A) Endoplasmic reticulum  
 B) Nucleolus  
 C) Golgi complex  
 D) Chromosomes
- Q.19 In which stage of Interphase, there is increase in cell size and many biochemical are formed?**  
 A) G<sub>2</sub> phase  
 B) G<sub>1</sub> phase  
 C) S phase  
 D) C phase
- Q.20 In Down's syndrome, which one of the following pair of chromosome fails to segregate?**  
 A) 7  
 B) 18  
 C) 21  
 D) 19

## 2013

- Q.21 The process by which unwanted structures within the cell are engulfed and digested within the lysosome is known as:**  
 A) Endocytosis  
 B) Exocytosis  
 C) Hydrolysis  
 D) Autophagy
- Q.22 The \_\_\_\_\_ model of plasma membrane suggests that proteins are embedded in lipid bilayer:**  
 A) Unit membrane  
 B) Fluid mosaic  
 C) Permeable  
 D) Ultracentrifuge
- Q.23 The function of nucleolus is to make:**  
 A) rDNA  
 B) Ribosomes  
 C) RNA  
 D) Chromosomes
- Q.24 Lipid metabolism is the function of:**  
 A) Mitochondria  
 B) Sarcoplasmic reticulum  
 C) RER  
 D) SER
- Q.25 The enzymes of lysosomes are synthesized on:**  
 A) RER  
 B) SER  
 C) Chloroplast  
 D) Golgi Apparatus

- Q.26 Centrioles are made up of \_\_\_\_\_ microtubules:**  
 A) 9  
 B) 27  
 C) 3  
 D) 12
- Q.27 Which of the following structures is absent in higher plants and found in animal cells:**  
 A) Centriole  
 B) Cytoskeleton  
 C) Mitochondria  
 D) Cytoplasm
- Q.28 The soluble part of cytoplasm or fluid that remains when all organelles are removed is known as:**  
 A) Solution  
 B) Gelatin material  
 C) Cytoskeleton  
 D) Cytosol
- Q.29 The outer membrane of the nuclear envelope is at places continuous with the:**  
 A) Golgi apparatus  
 B) Endoplasmic Reticulum  
 C) Lysozymes  
 D) Peroxisomes
- Q.30 Down's syndrome is a result of non-disjunction of \_\_\_\_\_ pair of chromosomes that fails to segregate:**  
 A) 21<sup>st</sup>  
 B) 22<sup>nd</sup>  
 C) 18<sup>th</sup>  
 D) 24<sup>th</sup>

## 2014

- Q.31 During animal cell division, the spindle fibres are formed from**  
 A) Mitochondria  
 B) Centrioles  
 C) Ribosomes  
 D) Lysosomes
- Q.32 Which component of the cell is concerned with cell secretions?**  
 A) Plasma membrane  
 B) Golgi complex  
 C) Cytoskeleton  
 D) Mitochondria
- Q.33 During which period of interphase (cell cycle) DNA is synthesized?**  
 A) G<sub>1</sub>  
 B) G<sub>2</sub>  
 C) S  
 D) G<sub>0</sub>
- Q.34 Peptidoglycan or murein is a special or distinctive feature of cell wall in**  
 A) Algae  
 B) Fungi  
 C) Bacteria  
 D) Plants
- Q.35 In mitochondria, small knob-like structures called F1 particles are found in:**  
 A) Outer membrane  
 B) Outer compartment  
 C) Inner membrane  
 D) Inner compartment
- Q.36 The most critical phase of mitosis which ensures equal distribution of chromatids in the daughter cells is**  
 A) Prophase  
 B) Metaphase  
 C) Anaphase  
 D) Telophase
- Q.37 Non-disjunction of 21<sup>st</sup> pair of chromosomes in one of the gamete leads to 47 chromosomes in one individual. This condition is called**  
 A) Turner's syndrome  
 B) Klinefelter's syndrome  
 C) Down's syndrome  
 D) Jacob's syndrome
- Q.38 The intake of liquid materials across the cell membrane is**  
 A) Phagocytosis  
 B) Endocytosis  
 C) Pinocytosis  
 D) Exocytosis

- Q.39 Which one of the following is the site of oxidative phosphorylation in mitochondria?**  
 A) Cristae  
 B) Matrix  
 C) Outer membrane  
 D) Ribosomes
- Q.40 Organelle involved in the synthesis of ATP is**  
 A) Ribosome  
 B) Mitochondria  
 C) Nucleus  
 D) Centriole

## 2015

- Q.41 During maternal mitosis, non-disjunction of autosomal chromosome pair results in the formation of an egg having 24 chromosomes in:**  
 A) Klinefelter's Syndrome  
 B) Down's Syndrome  
 C) Turner's Syndrome  
 D) Jacob's Syndrome
- Q.42 Typical symptoms like enlarged breasts and small testis in male are attributed to:**  
 A) Down's Syndrome  
 B) Turner's Syndrome  
 C) Klinefelter's Syndrome  
 D) Phenylketonuria
- Q.43 Fluid mosaic model of plasma membrane states that protein molecules float in a fluid \_\_\_\_\_ layer.**  
 A) Galactose  
 B) Phospholipids  
 C) Glucose  
 D) Carbohydrate
- Q.44 How many triplets of microtubules are present in centriole?**  
 A) Ten  
 B) Eight  
 C) Nine  
 D) Seven
- Q.45 Turner's syndrome is characterized by having:**  
 A) Trisomy 21  
 B) 44 + XXY  
 C) Trisomy 18  
 D) 44 + XO
- Q.46 Which one of the following cell structure is involved in the synthesis of lipids?**  
 A) Endoplasmic Reticulum  
 B) Golgi Complex  
 C) Centriole  
 D) Mitochondria
- Q.47 Ribosomes are tiny organisms, which are involved in the synthesis of:**  
 A) Protein  
 B) RNA  
 C) Nucleus  
 D) Nuclosome
- Q.48 Which organelle is bounded by two membranes?**  
 A) Ribosome  
 B) Mitochondria  
 C) Lysosome  
 D) Nucleolus
- Q.49 At the beginning of nuclear division, the number of microtubule triplets in two pairs of centrioles that migrate to opposite poles are:**  
 A) 9  
 B) 18  
 C) 108  
 D) 36
- Q.50 The disease in which an individual has extra sex chromosome (44 + XXY) is known as:**  
 A) Down's syndrome  
 B) Tuner's syndrome  
 C) Klinefelter's syndrome  
 D) Jacob's syndrome

## 2016

- Q.51 The rapid exchange of materials through carrier proteins across the plasma membrane is called:**  
 A) Passive Diffusion  
 B) Active Transport  
 C) Endocytosis  
 D) Facilitated Diffusion

- Q.52 The inner membrane of mitochondria form extensive infoldings called:**  
A) Cristae  
B) Cisternae  
C) Lamella  
D) Bifidae
- Q.53 Which one of the following organelle is found in both prokaryotic and eukaryotic cells?**  
A) Centriole  
B) Endoplasmic Reticulum  
C) Nucleus  
D) Ribosome
- Q.54 Out of the given options, choose the one which shows the structures found only in plants**  
A) Vacuole, Chloroplast, Ribosomes  
B) Chloroplast, Microtubules, Peroxisomes  
C) Chloroplast, Cell Wall, Vacuole  
D) Chloroplast, Cell Wall, Mitochondria
- Q.55 Presence of large central vacuole is the characteristic of:**  
A) Prokaryotes  
B) Protists  
C) Fungi  
D) Plants
- Q.56 The basic structure of plasma membrane is provided by:**  
A) Proteins  
B) Cholesterol  
C) Cytoskeleton  
D) Phospholipids
- Q.57 The organelle involved in detoxification of drugs and poisons in the liver cells is:**  
A) Smooth Endoplasmic Reticulum  
B) Rough Endoplasmic Reticulum  
C) Golgi Apparatus  
D) Lysosomes
- Q.58 Down's syndrome is characterized by \_\_\_\_\_ at chromosome 21.**  
A) Trisomy  
B) Monosomy  
C) Polysomy  
D) Disomy
- Q.59 Which of the following is an example of autosomal non-disjunction?**  
A) Turner's Syndrome  
B) Jacob's Syndrome  
C) Metastasis  
D) Down's syndrome
- Q.60 Infertility, short height, webbed neck and low hairline at lack are symptoms of \_\_\_\_\_ syndrome.**  
A) Turner's  
B) Down's  
C) Edward's  
D) Patau's

<b>ANSWERS</b>	Q.1	C	Q.16	C	Q.31	B	Q.46	B
	Q.2	A	Q.17	A	Q.32	B	Q.47	A
	Q.3	A	Q.18	B	Q.33	C	Q.48	B
	Q.4	A	Q.19	B	Q.34	C	Q.49	D
	Q.5	A	Q.20	C	Q.35	C	Q.50	C
	Q.6	B	Q.21	D	Q.36	C	Q.51	D
	Q.7	B	Q.22	B	Q.37	C	Q.52	A
	Q.8	A	Q.23	B	Q.38	C	Q.53	D
	Q.9	A	Q.24	D	Q.39	A	Q.54	C
	Q.10	B	Q.25	A	Q.40	B	Q.55	D
	Q.11	C	Q.26	B	Q.41	B	Q.56	D
	Q.12	B	Q.27	A	Q.42	C	Q.57	A
	Q.13	C	Q.28	D	Q.43	B	Q.58	A
	Q.14	D	Q.29	A	Q.44	C	Q.59	D
	Q.15	C	Q.30	A	Q.45	D	Q.60	A

## 3

## BIOLOGICAL MOLECULES

## 2011

- Q.1 The covalent bond formed between two monosaccharides is called**  
 A) Glycosidic Bond  
 B) Hydrogen Bond  
 C) Peptide Bond  
 D) Disulphide
- Q.2 The bond formed between glucose and fructose form sucrose is**  
 A) 1,4 Glycosidic Linkage  
 B) 1,2 Glycosidic Linkage  
 C) 1,6 Glycosidic Linkage  
 D) 1,3 Glycosidic Linkage
- Q.3 In an amino acid in which the R-group is H, its name will be**  
 A) Alanine  
 B) Glycine  
 C) Leucine  
 D) Valine
- Q.4 Fatty acid are the organic compounds containing hydrogen, oxygen and one of the following are**  
 A)  $-\text{COOH}$   
 B)  $-\text{NH}_2$   
 C) Acyl  
 D) Sucrose
- Q.5 The combination of a pentose sugar with a base result in a compound is known as**  
 A) Nucleotide  
 B) Nucleoside  
 C) Nucleic Acid  
 D) Polynucleotide
- Q.6 An enzyme and substrate reacts through a special feature or site present in enzyme:**  
 A) Building Site  
 B) Active Site  
 C) Catalyst Site  
 D) Inhibition Site
- Q.7 The non-protein part of enzyme which is covalently and permanently bonded is called**  
 A) Prosthetic Group  
 B) Co-Factor  
 C) Co-Enzyme  
 D) Activator
- Q.8 One of the pyrimidine bases is absent in DNA**  
 A) Uracil  
 B) Thymine  
 C) Cytosine  
 D) Adenine
- Q.9 Enzymes increase the rate of reaction by**  
 A) Increasing Temperature  
 B) Decreasing pH  
 C) Decreasing Activation Energy  
 D) Increasing Activation Energy

## 2012

- Q.10 Carbohydrates are organic molecules and contain three elements**  
 A) Carbon, water and oxygen  
 B) Carbon, Sulphur and hydrogen  
 C) Carbon, calcium and hydrogen  
 D) Carbon, hydrogen and oxygen
- Q.11 Which one are intermediates in respiration and photosynthesis both?**  
 A) Ribose and heptolose  
 B) Glyceraldehydes and dihydroxyacetone  
 C) Glucose and galactose  
 D) Fructose and ribulose

- Q.12 Which of the following is a peptide bond?**  
 A) –C–N  
 B) –C–O  
 C) –C–P  
 D) –C–S
- Q.13 Which of the following is an unsaturated fatty acid?**  
 A) Acetic Acid  
 B) Butyric acid  
 C) Oleic acid  
 D) Palmitic acid
- Q.14 Which of the following combination of base pair is absent in DNA?**  
 A) A–T  
 B) C–G  
 C) A–U  
 D) T–A
- Q.15 The type of inhibition in which inhibitor has no structural similarity to substrate and combines with enzyme at other than the active site is called**  
 A) Irreversible inhibition  
 B) Competitive inhibition  
 C) Non-competitive and reversible inhibition  
 D) Reversible inhibition
- Q.16 The inhibitors that bind tightly and permanently to enzymes and destroy their globular structure and catalytic activity are**  
 A) Reversible inhibitors  
 B) Irreversible inhibitors  
 C) Competitive inhibitors  
 D) Non-competitive inhibitors
- Q.17 Enzyme succinate dehydrogenase converts succinate into**  
 A) Malate  
 B) Malonic acid  
 C) Citrate  
 D) Fumarate
- Q.18 If the detachable co-factor is an inorganic ion then it is designated as**  
 A) Coenzyme  
 B) Prosthetic group  
 C) Holoenzyme  
 D) Activator
- Q.19 \_\_\_\_\_ is most abundant carbohydrate in nature.**  
 A) Waxes  
 B) Glycerol  
 C) Starch  
 D) Cellulose
- Q.20 Which of the following is a keto sugar:**  
 A) Glyceraldehyde  
 B) Dihydroxy-acetone  
 C) Ribose  
 D) Glucose
- Q.21 Amino acid in which the R-group is hydrogen is:**  
 A) Glycine  
 B) Alanine  
 C) Leucine  
 D) Valine
- Q.22 Acyl-glycerols like fats and oils are esters formed by condensation reaction between:**  
 A) Fatty acids and water  
 B) Fatty acids and alcohols  
 C) Fatty acids and glucose  
 D) Fatty acids and phosphates
- Q.23 Which of the following is purine:**  
 A) Guanine  
 B) Cytosine  
 C) Thymine  
 D) Uracil
- Q.24 If the co-factor is covalently or tightly and permanently bonded to enzyme then it will be called:**  
 A) Coenzyme  
 B) Prosthetic group  
 C) Activator  
 D) Apoenzyme
- Q.25 Optimum pH value for the working of pancreatic lipase is:**  
 A) 4.50  
 B) 7.60  
 C) 2.00  
 D) 9.00



- Q.26 The view that active site of an enzyme is flexible and when a substrate combines with it, cause changes in enzyme structure is known as:**
- A) Lock & key model  
B) Induce fit model  
C) Sliding filament model  
D) Specificity model
- Q.27 All coenzymes are derived from:**
- A) Proteins  
B) Nucleic acids  
C) Carbohydrate  
D) Vitamins

## 2014

- Q.28 The most common respiratory substrate as a source of energy is**
- A) Glucose  
B) Sucrose  
C) Fructose  
D) Insulin
- Q.29 The simplest monosaccharide containing keto group is**
- A) Glyceraldehyde  
B) Dihydroxy acetone  
C) Glucose  
D) Ribose
- Q.30 If the genetic code is made up of three nucleotides, then total possible genetic codes will be**
- A) 4  
B) 20  
C) 64  
D) 61
- Q.31 Waterproof surfaces like cuticle of leaf and protective covering of an insect's body are**
- A) Phospholipids  
B) Waxes  
C) Terpenoids  
D) Acyl glycerols
- Q.32 In translation the terminating codon is**
- A) GUA  
B) UAA  
C) UUG  
D) AGU
- Q.33 All co-enzymes are derived from**
- A) Proteins  
B) Carbohydrates  
C) Metal ions  
D) Vitamins
- Q.34 The competitive inhibitors have structural similarity with**
- A) Active site  
B) Binding site  
C) Substrate  
D) Co-enzyme
- Q.35 Which one of the following is the optimum pH of pancreatic lipase enzyme?**
- A) 7.60  
B) 8.00  
C) 9.00  
D) 9.70
- Q.36 A co-factor tightly bound to the enzyme on the permanent basis is called**
- A) Activator  
B) Co-enzyme  
C) Prosthetic group  
D) Apo-enzyme

## 2015

- Q.37 Monosaccharides are major components of:**
- A) DNA, ATP, Ribulose biphosphate and Cysteine  
B) DNA, NAD and Insulin  
C) DNA, NADP, ATP and Ribulose biphosphate  
D) DNA, RNA and Myosin
- Q.38 Blood group antigen contains:**
- A) Glycoproteins  
B) Phospholipids  
C) Glycolipids  
D) Sphingolipids

- Q.39 Myosin is a \_\_\_\_\_ type of protein.**  
 A) Intermediate  
 B) Simple  
 C) Globular  
 D) Fibrous
- Q.40 Which one of the following is an example of unsaturated fatty acid?**  
 A) Butyric Acid  
 B) Oleic Acid  
 C) Palmitic Acid  
 D) Acetic Acid
- Q.41 Number of base pairs in one turn of DNA is:**  
 A) 10  
 B) 2  
 C) 34  
 D) 54
- Q.42 Which molecular structure of enzyme is essential for activity of enzyme?**  
 A) Primary Structure  
 B) Quaternary Structure  
 C) Secondary Structure  
 D) Tertiary Structure
- Q.43 Some enzymes require helper which is non-protein part for its efficient functioning that is called:**  
 A) Accelerator  
 B) Cofactor  
 C) Prosthetic group  
 D) Apoenzyme
- Q.44 Pepsin, protein digesting enzymes, sets best pH:**  
 A) 3.00  
 B) 4.50  
 C) 2.00  
 D) 6.00
- Q.45 Which one of the following is an example of competitive inhibitor?**  
 A) Glucose  
 B) Fumerate  
 C) Succinic Acid  
 D) Melonate

2016

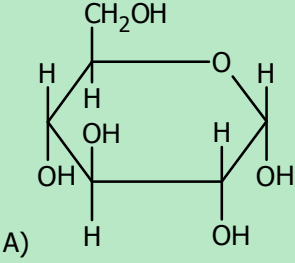
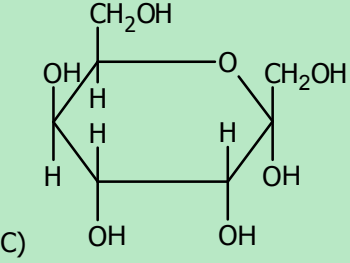
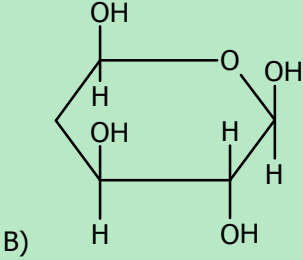
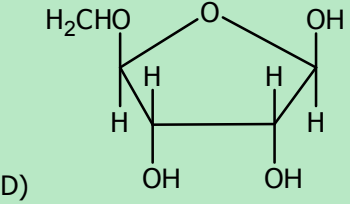
- Q.46 The compounds which on hydrolysis yield polyhydroxy aldehyde or ketone subunits are:**  
 A) Lipids  
 B) Proteins  
 C) Polynucleotides  
 D) Carbohydrates
- Q.47 Which one of the following is the formula structure of D ( $\alpha$ ) glucose?**
- A) 
- C) 
- B) 
- D) 
- Q.48 Secondary structure of protein is found in:**  
 A) Trypsin  
 B) Keratin  
 C) Insulin  
 D) Glucagon

**Q.49 Waxes are formed by combination of fatty acids with:**

- A) Alcohol  
B) Glycerol  
C) Serine  
D) Cysteine

**Q.50 Phosphodiester bond is:**

- A)  $P-O-C-P-O-C$   
B)  $C-O-P$   
C)  $C-O-P-O-C$   
D)  $C-C-O-P$

**Q.51 An enzyme required  $Mg^{++}$  to catalyze the substrate. The  $Mg^{++}$  is best identified as:**

- A) Prosthetic group  
B) Activator  
C) Co-enzyme  
D) Inhibitor

**Q.52**

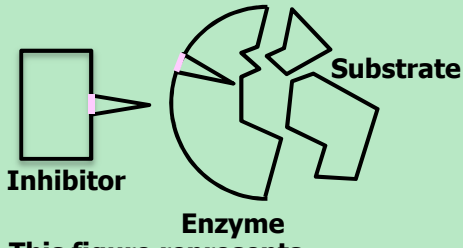

**This figure represents \_\_\_\_\_ inhibitor.**

- A) Non-competitive  
B) Competitive  
C) Irreversible  
D) Isosteric

**Q.53 According to \_\_\_\_\_ model the active site of enzyme is modified as the substrate interacts with enzyme.**

- A) Induced fit  
B) Lock and Key  
C) Emil Fischer  
D) Fluid Mosaic

**Q.54 Which one of the following graphs shows how the rate of reaction of pepsin is affected by pH?**

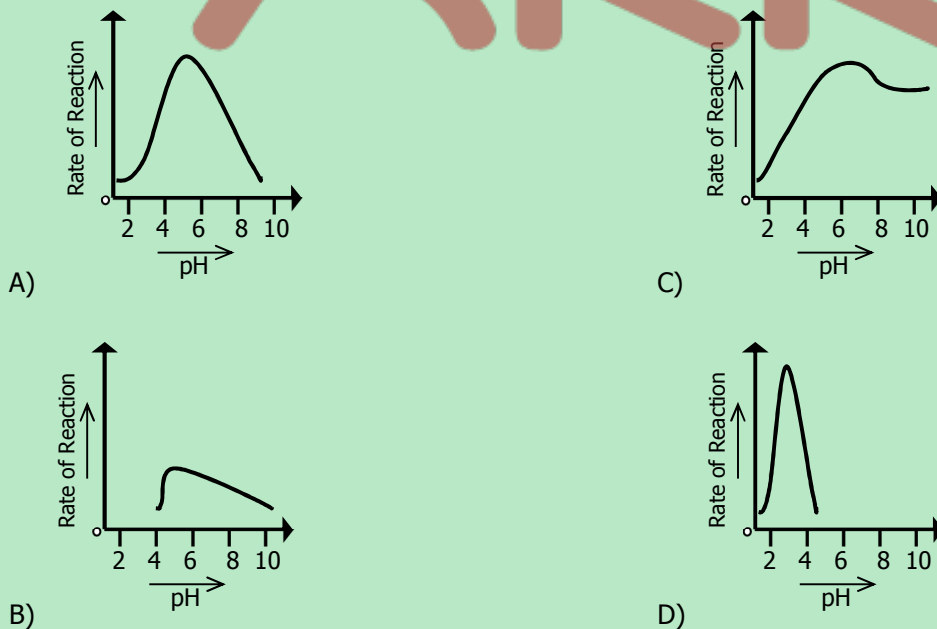

<b>ANSWERS</b>	Q.1	A	Q.16	B	Q.31	B	Q.46	D
	Q.2	B	Q.17	D	Q.32	B	Q.47	A
	Q.3	B	Q.18	D	Q.33	D	Q.48	B
	Q.4	A	Q.19	D	Q.34	C	Q.49	A
	Q.5	B	Q.20	B	Q.35	C	Q.50	C
	Q.6	B	Q.21	A	Q.36	C	Q.51	B
	Q.7	A	Q.22	B	Q.37	C	Q.52	A
	Q.8	A	Q.23	A	Q.38	A	Q.53	A
	Q.9	C	Q.24	B	Q.39	D	Q.54	D
	Q.10	D	Q.25	D	Q.40	B		
	Q.11	B	Q.26	B	Q.41	A		
	Q.12	A	Q.27	D	Q.42	D		
	Q.13	C	Q.28	A	Q.43	B		
	Q.14	C	Q.29	B	Q.44	C		
	Q.15	C	Q.30	C	Q.45	D		

## 4

## MICROBIOLOGY

## 2011

- Q.1 Which one of the following diseases caused by enveloped RNA virus and spread in epidemic form?**  
 A) Influenza  
 B) Herpes Simplex  
 C) Polio  
 D) Small Pox
- Q.2 The structure which contains the gene for drug resistance bacteria are**  
 A) Nucleoids  
 B) Mesosomes  
 C) Chromatin Bodies  
 D) Plasmids
- Q.3 Antibiotics that kill microbes immediately are called**  
 A) Microbistatic  
 B) Microbicidal  
 C) Biostatic  
 D) Chemotherapeutic
- Q.4 Which one of the following fungi causes vaginal thrush?**  
 A) Candida  
 B) Aspergillus  
 C) Tortula  
 D) Penicillium

## 2012

- Q.5 In HIV viruses, reverse transcriptase converts single-stranded RNA into double stranded viral DNA. This process is called**  
 A) Translation  
 B) Duplication  
 C) Replication  
 D) Reverse Transcriptase
- Q.6 Mesosomes are infoldings of the cell membrane and are involved in**  
 A) DNA replication  
 B) RNA synthesis  
 C) Protein synthesis  
 D) Metabolism
- Q.7 Most widespread problem of the antibiotics misuse is the**  
 A) Rapid cure  
 B) Increased resistance in pathogen  
 C) Disturbance of metabolism  
 D) Immunity
- Q.8 Which of the following component is found in the cell wall of fungi?**  
 A) Cellulose  
 B) Chitin  
 C) Proteins  
 D) Glycerol

## 2013

- Q.9 Reverse transcription is used to make DNA copies of:**  
 A) Host RNA  
 B) Viral RNA  
 C) Host DNA  
 D) Viral DNA
- Q.10 Antibiotics are produced by fungi and certain bacteria of group:**  
 A) Actinomycetes  
 B) Oomycetes  
 C) Ascomycetes  
 D) Basidiomycetes

- Q.11 Which statement about bacteria is true:**  
 A) Gram positive bacteria have more lipids in their cell wall  
 B) Gram negative bacteria have more lipids in their cell wall  
 C) Lipids are absent in cell wall of both gram positive and negative bacteria  
 D) Both have equal amount of lipids

- Q.12 Fungi which cause thrush in humans:**  
 A) Sarcomeres  
 B) Candidiasis  
 C) Lovastatin  
 D) Aspergillus

## 2014

- Q.13 Which one of the following cells are mainly infected by HIV?**  
 A) T-killer lymphocytes  
 B) T-helper lymphocytes  
 C) B-plasma cells  
 D) B-memory cells
- Q.14 Which one of the following antibiotic causes permanent discoloration of teeth in young children if it is misused?**  
 A) Penicillin  
 B) Streptomycin  
 C) Sulfonamide  
 D) Tetracycline
- Q.15 What are the sequence of steps in which a bacteriophage attacks bacteria and injects its DNA?**  
 A) Landing → Tail contraction → Penetration → DNA Injection  
 B) Penetration → Landing → Tail contraction → DNA Injection  
 C) Tail contraction → Landing → DNA Injection → Penetration  
 D) Landing → Penetration → Tail contraction → DNA Injection
- Q.16 Athlete's Foot is a disease caused by**  
 A) Bacteria  
 B) Virus  
 C) Fungus  
 D) Arthropod

## 2015

- Q.17 HIV is classified as:**  
 A) Bacteriophage  
 B) Oncovirus  
 C) Retrovirus  
 D) Icosahedral virus
- Q.18 Cyanobacteria are:**  
 A) Photoautotrophic bacteria  
 B) Chemosynthetic bacteria  
 C) Saprotrophic bacteria  
 D) Parasitic bacteria
- Q.19 During favourable conditions, certain bacteria produces:**  
 A) Ribosomes  
 B) Plasmids  
 C) Mitochondria  
 D) Spores
- Q.20 In rhizopus, zygote forms temporary, dormant, thick-walled resistant structure called:**  
 A) Zygosporangium  
 B) Spore  
 C) Sporangia  
 D) Hydra

## 2016

- Q.21 All viruses can reproduce within living organisms only, so they are known as:**  
 A) Ectoparasites  
 B) Endoparasites  
 C) Obligative Intracellular Parasites  
 D) Facultative Intracellular Parasites
- Q.22 Many bacteria are motile due to presence of:**  
 A) Flagella  
 B) Pili  
 C) Cilia  
 D) Microtubules

**Q.23** \_\_\_\_\_ is an invagination of cell membrane which helps in cell division.

- A) Fimbriae  
 B) Nucleoid  
 C) Mesosome  
 D) Endospore

**Q.24** \_\_\_\_\_ is the yeast that grows in the mucous membrane of mouth or vagina.

- A) Candida albicans  
 B) Saccharomyces cerevisiae  
 C) Aspergillus fumigatus  
 D) Aspergillus flavus

<b>ANSWERS</b>	<b>Q.1</b>	A	<b>Q.7</b>	B	<b>Q.13</b>	B	<b>Q.19</b>	D
	<b>Q.2</b>	D	<b>Q.8</b>	B	<b>Q.14</b>	D	<b>Q.20</b>	A
	<b>Q.3</b>	B	<b>Q.9</b>	D	<b>Q.15</b>	A	<b>Q.21</b>	C
	<b>Q.4</b>	A	<b>Q.10</b>	A	<b>Q.16</b>	C	<b>Q.22</b>	A
	<b>Q.5</b>	D	<b>Q.11</b>	B	<b>Q.17</b>	C	<b>Q.23</b>	C
	<b>Q.6</b>	A	<b>Q.12</b>	B	<b>Q.18</b>	A	<b>Q.24</b>	A

## 5

## KINGDOM ANIMALIA

## 2011

- Q.1 Body cavity of round worms is called**  
 A) Pseudocoelom  
 B) Coelom  
 C) Acoelom  
 D) Enteron
- Q.2 Fasciola is endoparasite of**  
 A) Colon  
 B) Liver  
 C) Small Intestine  
 D) Bile Duct
- Q.3 Trypanosoma is transmitted in human beings by**  
 A) Plasmodium  
 B) Anopheles  
 C) House Fly  
 D) Tsetse Fly
- Q.4 The nervous system develops from which of the following layer during embryonic development of animals**  
 A) Mesoderm  
 B) Ectoderm  
 C) Endoderm  
 D) Mesoderm and Endoderm
- Q.5 Endosperm is formed as a result of**  
 A) Pollination  
 B) Self-Pollination  
 C) Double Fertilization  
 D) Cross Pollination

## 2012

- Q.6 The male reproductive parts of the flower are called**  
 A) Gynoecium  
 B) Calyx  
 C) Androecium  
 D) Corolla
- Q.7 Fasciola is the name given to**  
 A) Tapeworm  
 B) Planaria  
 C) Liver fluke  
 D) Earthworm
- Q.8 Ascaris is**  
 A) Diploblastic  
 B) Triploblastic  
 C) Haploid  
 D) Acoelomate
- Q.9 During development, in an animal, mesoderm layer gives rise to**  
 A) Nervous System  
 B) Alimentary canal lining  
 C) Muscular and skeletal system  
 D) Mouth
- Q.10 Polymorphism is characteristic feature of**  
 A) Porifera  
 B) Cnidaria  
 C) Annelida  
 D) Nematodes



## 2013

- Q.11** When beef which is not properly cooked is consumed by humans, they become infected by:  
 A) Tape worm  
 B) Hook worm  
 C) Pin worm  
 D) Round worm
- Q.12** Sleeping sickness in humans is caused by:  
 A) Trypanosoma  
 B) Plasmodium  
 C) Anopheles  
 D) Andes
- Q.13** Schistosoma is a parasite that lives in the \_\_\_\_\_ of the host.  
 A) Intestine  
 B) Kidney  
 C) Liver  
 D) Blood
- Q.14** The cavity between body wall and alimentary canal is:  
 A) Coelom  
 B) Mesoderm  
 C) Endoderm  
 D) Mesoglea
- Q.15** The layer which forms the lining of digestive tract and glands of digestive system is:  
 A) Ectoderm  
 B) Mesoderm  
 C) Endoderm  
 D) Mesoglea

## 2014

- Q.16** Ascaris is which one of the following?  
 A) Ectoparasite  
 B) Intestinal parasite  
 C) Respiratory tract parasite  
 D) Urinogenital tract parasite
- Q.17** Polymorphism is a feature exhibited by members of  
 A) Coelenterates  
 B) Arthropoda  
 C) Porifera  
 D) Platyhelminthes
- Q.18** Which one of the following is the primary host of liver fluke?  
 A) Man  
 B) Sheep  
 C) Snail  
 D) Dog
- Q.19** Which one of the following is an example of a free living carnivorous flatworm?  
 A) Liver fluke  
 B) Dugesia  
 C) Tapeworm  
 D) Schistosoma
- Q.20** The sources of staple food for man are plants which belong to the family:  
 A) Mimosaceae  
 B) Poaceae  
 C) Rosaceae  
 D) Fabaceae

## 2015

- Q.21** \_\_\_\_\_ is a triploblastic organism.  
 A) Jelly Fish  
 B) Sea Anemone  
 C) Tapeworm  
 D) Corals
- Q.22** In arthropods, the body cavity is in the form of:  
 A) Coelem  
 B) Haemocoel  
 C) Pseudocoelom  
 D) Enteron
- Q.23** \_\_\_\_\_ is a good example of polymorphism.  
 A) Hydra  
 B) Starfish  
 C) Obelia  
 D) Euplectella

- Q.24 Name common gut roundworm parasite of human and pigs.**  
 A) Aascaris lumberocoides C) Pheretima posthuma  
 B) Lumbericus terresaris D) Hirudo Medicinalis
- Q.25 \_\_\_\_\_ is also called liver fluke.**  
 A) Dugesia C) Fasciola  
 B) Taenia D) Coral

## 2016

- Q.26 Taenia is an endoparasite of human, pig and cattle which belongs to phylum.**  
 A) Cnidaria C) Annelida  
 B) Aschelminthes D) Platyhelminthes
- Q.27 Body of \_\_\_\_\_ consists of segments called proglottis which contains mainly sex organs.**  
 A) Planaria C) Fasciola  
 B) Ascaris D) Tapeworm
- Q.28 \_\_\_\_\_ is a common parasite of the intestine of human and pig which belongs to phylum nematode.**  
 A) Taenia solanum C) Ascaris lumbricoides  
 B) Schistosoma D) Fasciola hepatica
- Q.29 In radial symmetry all body parts are arranged around the central axis. Radial symmetry represents \_\_\_\_\_ mode of life.**  
 A) Sessile C) Active  
 B) Streamlined D) Parasitic
- Q.30 Pseudo-coelomates have a body cavity but it is not true coelom. Which one of the following is included in the group.**  
 A) Planaria C) Earthworm  
 B) Tapeworm D) Ascaris

ANSWERS	Q.1	A	Q.9	C	Q.17	B	Q.25	C
	Q.2	D	Q.10	B	Q.18	B	Q.26	D
	Q.3	D	Q.11	A	Q.19	B	Q.27	D
	Q.4	B	Q.12	A	Q.20	B	Q.28	C
	Q.5	C	Q.13	D	Q.21	C	Q.29	A
	Q.6	C	Q.14	A	Q.22	B	Q.30	D
	Q.7	C	Q.15	C	Q.23	C		
	Q.8	B	Q.16	B	Q.24	A		



HUMAN PHYSIOLOGY

## 6A

## DIGESTIVE SYSTEM

## 2011

- Q.1 Which of the following enzyme is released in an inactive form**  
 A) Amylase  
 B) Lipase  
 C) Enterokinase  
 D) Pepsin
- Q.2 Which of the following hormones stimulate the secretion of pancreatic juice from pancreas in liver?**  
 A) Secretin  
 B) Pepsinogen  
 C) Gastrin  
 D) Both Gastrin and Secretin
- Q.3 In large intestine, vitamin K is formed by the activity of**  
 A) Symbiotic Bacteria  
 B) Obligate Bacteria  
 C) Parasitic Bacteria  
 D) Facultative Bacteria
- Q.4 During swallowing of food which structure close nasal opening?**  
 A) Hard Palate  
 B) Soft Palate  
 C) Epiglottis  
 D) Larynx

## 2012

- Q.5 The muscles of the stomach walls thoroughly mix up the food with gastric juices and the resulting semi-solid / semi-liquid material is called**  
 A) Bolus  
 B) Bolus or chime  
 C) Mucus  
 D) Chyme
- Q.6 Trypsinogen is converted into trypsin by the activity of**  
 A) Goblet cells  
 B) Absorptive cells  
 C) Enterokinase  
 D) Peptidase
- Q.7 In large intestines, vitamin K is formed by the activity of**  
 A) Symbiotic bacteria  
 B) Obligate parasite  
 C) Parasitic bacteria  
 D) Facultative bacteria
- Q.8 Goblet cells secrete**  
 A) HCl  
 B) Mucus  
 C) Enzymes  
 D) Amylase

## 2013

- Q.9 Which one of the following vitamins is produced by microflora of large intestine?**  
 A) Vitamin K  
 B) Vitamin C  
 C) Vitamin A  
 D) Vitamin D
- Q.10 \_\_\_\_\_ is activated to \_\_\_\_\_ by Enterokinase/enteropeptidase enzyme secreted by the lining of duodenum:**  
 A) Pepsinogen, Pepsin  
 B) Pepsinogen, Trypsin  
 C) Trypsinogen, Trypsin  
 D) Chymotrypsinogen, Chymotrypsin

- Q.11 Which of the following are absorbed in the large intestine?**  
 A) Water and salts  
 B) Water and peptones  
 C) Salts and glycerol  
 D) Amino acids and sugars
- Q.12 Saliva is basically composed of water, mucus, amylase and:**  
 A) Sodium bicarbonate  
 B) Sodium chloride  
 C) Sodium hydroxide  
 D) Hydrocarbons

## 2014

- Q.13 In human, Escherichia coli is involved in the formation of**  
 A) Calcium  
 B) Vitamin D  
 C) Vitamin A  
 D) Vitamin K
- Q.14 The function of Goblet cells is to secrete**  
 A) Gastrin  
 B) Hydrochloric acid  
 C) Pepsinogen  
 D) Mucus
- Q.15 Gastric glands are composed of \_\_\_\_\_ types of cells**  
 A) Two  
 B) Three  
 C) Four  
 D) Five
- Q.16 HCl in gastric juice is secreted by which one of the following cells?**  
 A) Chief cells  
 B) Oxyntic cells  
 C) Mucous cells  
 D) Kupffer cells

## 2015

- Q.17 The lymph vessel of villi is called:**  
 A) Epithelium  
 B) Afferent lymph vessel  
 C) Adrenals  
 D) Lacteal
- Q.18 Oxyntic cells in stomach produces:**  
 A) Pepsin  
 B) Pepsinogen  
 C) Gastrin  
 D) HCl
- Q.19 The hormone which inhibits the secretion of pancreatic juice is:**  
 A) Secretin  
 B) Gastrin  
 C) Thyroxine  
 D) Parathormone
- Q.20 Trypsinogen is activated to trypsin by:**  
 A) HCl  
 B) Enterokinase  
 C) Mucus  
 D) Gastrin
- Q.21 The emulsification of fats is the role of:**  
 A) Saliva  
 B) Pancreatic juice  
 C) Gastrin  
 D) Bile

## 2016

- Q.22 Digestion of \_\_\_\_\_ starts in oral cavity due to the action of enzyme present in saliva.**  
 A) Starch  
 B) Cellulose  
 C) Fatty Acids  
 D) Polypeptides
- Q.23 Food enters from stomach into small intestine through:**  
 A) Pyloric Sphincter  
 B) Cardiac Sphincter  
 C) Semilunar valve  
 D) Diaphragm

**Q.24** \_\_\_\_\_ are the part of a gastric gland which produce hydrochloric acid.

- A) Parietal Cells  
 B) Goblet Cells  
 C) Chief Cells  
 D) Zymogen Cells

**Q.25** Protein components of food are digested by the enzymatic secretion of:

- A) Goblet Cells  
 B) Parietal Cells  
 C) Zymogen Cells  
 D) Oxyntic Cells

**Q.26** Digestive System consists of different layers, the innermost is known as:

- A) Submucosa  
 B) Mucosa  
 C) Muscularis  
 D) Serosa

<b>ANSWERS</b>	<b>Q.1</b>	D	<b>Q.8</b>	B	<b>Q.15</b>	B	<b>Q.22</b>	A
	<b>Q.2</b>	A	<b>Q.9</b>	A	<b>Q.16</b>	B	<b>Q.23</b>	A
	<b>Q.3</b>	A	<b>Q.10</b>	C	<b>Q.17</b>	D	<b>Q.24</b>	A
	<b>Q.4</b>	B	<b>Q.11</b>	A	<b>Q.18</b>	D	<b>Q.25</b>	C
	<b>Q.5</b>	D	<b>Q.12</b>	A	<b>Q.19</b>	A	<b>Q.26</b>	B
	<b>Q.6</b>	C	<b>Q.13</b>	D	<b>Q.20</b>	B		
	<b>Q.7</b>	A	<b>Q.14</b>	D	<b>Q.21</b>	D		

**ARK**

## 6B

## GAS EXCHANGE &amp; TRANSPORTATION

## 2011

- Q.1 The right atrium of the heart usually receives the**  
 A) Deoxygenated Blood  
 B) Oxygenated Blood  
 C) Filtered Blood  
 D) Non-Filtered Blood
- Q.2 The largest lymph duct called thoracic lymph duct drains into**  
 A) Subclavian Vein  
 B) Renal Vein  
 C) Pulmonary Vein  
 D) Hepatic Portal Vein
- Q.3 Which protein plays a major role in maintaining osmotic balance?**  
 A) Albumin  
 B) Globulin  
 C) Fibrinogen  
 D) Prothrombin
- Q.4 The type of agranulocytes which stays in blood for a few hours and then enters tissues and become macrophages are**  
 A) Lymphocytes  
 B) Monocyte  
 C) Eosinophils  
 D) Basophils

## 2012

- Q.5 Mature mammalian red blood cells do not have**  
 A) Nucleus  
 B) Red color  
 C) Fluids  
 D) Haemoglobin
- Q.6 In a normal person plasma constitutes about \_\_\_\_\_ by volume of blood**  
 A) 50%  
 B) 60%  
 C) 45%  
 D) 55%
- Q.7 Which vein has oxygenated blood?**  
 A) Renal vein  
 B) Subclavian vein  
 C) Pulmonary vein  
 D) Jugular vein
- Q.8 What is the residual volume of air which always remains inside the lungs of human?**  
 A) 3.5 Liters  
 B) 0.5 Liters  
 C) 5.0 Liters  
 D) 1.5 Liters

## 2013

- Q.9 The total inside capacity of lungs is \_\_\_\_\_ for man.**  
 A) 6.7 liters  
 B) 2.5 liters  
 C) 7 liters  
 D) 5 liters
- Q.10 The average life span of red blood cell is about:**  
 A) Four months  
 B) Two months  
 C) Five months  
 D) One month

**Q.11 The lymphatic vessels of the body empty the lymph into blood stream at the:**

- A) Abdominal vein  
B) Subclavian vein  
C) Jugular vein  
D) Bile duct

**Q.12 Right atrium is separated from right ventricle by:**

- A) Tricuspid valve  
B) Bicuspid valve  
C) Semilunar valve  
D) Septum

## 2014

**Q.13 Histamine is produced by which one of the following cells?**

- A) Basophils  
B) Platelets  
C) Monocyte  
D) Eosinophils

**Q.14 Which one of the following is the most numerous / commonest of white blood cells?**

- A) Eosinophils  
B) Monocytes  
C) Neutrophils  
D) Lymphocytes

**Q.15 The oxygenated blood from lungs to heart is transported by the**

- A) Pulmonary artery  
B) Coronary artery  
C) Pulmonary vein  
D) Hepatic artery

**Q.16 Which one of the following proteins takes part in blood clotting?**

- A) Prothrombin  
B) Fibrinogen  
C) Immunoglobulin  
D) Globulin

## 2015

**Q.17 Right atrium is separated from right ventricle by:**

- A) Bicuspid Valve  
B) Semilunar Valve  
C) Tricuspid Valve  
D) Interatrial Septum

**Q.18 The flaps of tricuspid valves are attached to muscular extensions of right ventricle known as:**

- A) Smooth Muscles  
B) Papillary Muscles  
C) Intercostal Muscles  
D) Skeletal Muscles

**Q.19 One complete heart beat consists of one systole and one diastole and lasts for about:**

- A) 0.8 sec  
B) 0.2 sec  
C) 0.4 sec  
D) 0.5 sec

**Q.20 The heart beat cycle starts when electric impulses are generated from;**

- A) AV Node  
B) SV Node  
C) SA Node  
D) PQ Node

**Q.21 About 70-85% CO<sub>2</sub> in blood is carried:**

- A) As carboxylase myoglobin  
B) With proteins in plasma  
C) Freely as CO<sub>2</sub>  
D) As bicarbonate

## 2016

**Q.22 In human the closed sac which surrounds the heart is:**

- A) Endocardium  
B) Myocardium  
C) Pericardium  
D) Epicardium

**Q.23 Chordae tendinea are fibrous cords attached with:**

- A) Cardiac end of stomach valve  
B) Tricuspid valve of heart  
C) Pyloric sphincter of stomach  
D) Eyelid



**Q.24 Bicuspid valve controls the flow of blood from:**

- A) Right atrium to right ventricle  
 B) Right ventricle to pulmonary artery  
 C) Left ventricle to aorta  
 D) Left atrium to left ventricle

**Q.25 Carboxyhaemoglobin (10-20%) is formed when CO<sub>2</sub> combines with:**

- A) Amino group of haemoglobin  
 B) Iron part of haemoglobin  
 C) Haem portion of haemoglobin  
 D) Plasma proteins

**Q.26 Breathing consists of:**

- A) Four phases  
 B) Three phases  
 C) One phase  
 D) Two phases

<b>ANSWERS</b>	<b>Q.1</b>	A	<b>Q.8</b>	D	<b>Q.15</b>	C	<b>Q.22</b>	C
	<b>Q.2</b>	A	<b>Q.9</b>	D	<b>Q.16</b>	B	<b>Q.23</b>	B
	<b>Q.3</b>	A	<b>Q.10</b>	A	<b>Q.17</b>	C	<b>Q.24</b>	D
	<b>Q.4</b>	B	<b>Q.11</b>	B	<b>Q.18</b>	B	<b>Q.25</b>	A
	<b>Q.5</b>	A	<b>Q.12</b>	A	<b>Q.19</b>	A	<b>Q.26</b>	D
	<b>Q.6</b>	D	<b>Q.13</b>	A	<b>Q.20</b>	C		
	<b>Q.7</b>	C	<b>Q.14</b>	D	<b>Q.21</b>	D		

ARK

6C

## EXCRETION AND OSMOREGULATION

2011

- Q.1 Reabsorption of water by counter current multiplier mechanism takes place at**  
 A) Proximal Tubule  
 B) Distal Tubule  
 C) Collecting Duct  
 D) Loop of Henle
- Q.2 Antidiuretic hormone helps in reabsorption of water by changing permeability of**  
 A) Proximal Tubule  
 B) Distal Tubule  
 C) Collecting Duct  
 D) Loop of Henle
- Q.3 During peritoneal dialysis, dialysis fluid is introduced into which part of human body?**  
 A) Liver  
 B) Abdomen  
 C) Kidney  
 D) Pancreas
- Q.4 Aldosterone helps in conservation or active absorption of**  
 A) Sodium  
 B) Calcium  
 C) Potassium  
 D) Bicarbonate Ions
- Q.5 Maximum reabsorption takes place in which part of the nephron?**  
 A) Distal Tubule  
 B) Villi  
 C) Cortical Tissue  
 D) Proximal Tubule

2012

- Q.6 In nephron, most of the reabsorption takes place in the**  
 A) Distal tubule  
 B) Proximal tubule  
 C) Ascending limb  
 D) Descending limb
- Q.7 Detection of change and signaling for effector's response to the control system is a**  
 A) Negative feedback  
 B) Positive feedback  
 C) Inter-coordination  
 D) Feedback mechanism
- Q.8 What are three components of mechanism of homeostatic regulations?**  
 A) Receptors, control centre and effectors  
 B) Sensory, motor and associative neurons  
 C) CNS, PNS and diffused nervous system  
 D) Cerebrum, cerebellum and pons
- Q.9 Blood enters the glomerulus through**  
 A) Efferent arteriole  
 B) Afferent arteriole  
 C) Renal artery  
 D) Renal vein
- Q.10 Which portion of nephron is under the control of ADH?**  
 A) Bowman's capsule  
 B) Ascending arm  
 C) Distal and collecting ducts  
 D) Descending arm

## 2013

- Q.11 Site of filtration in nephron is:**  
 A) Glomerulus and Bowman's capsule  
 B) Proximal and Distal end  
 C) Ascending and descending arm  
 D) Loop of Henle
- Q.12 Antidiuretic hormone increases the reabsorption of:**  
 A) Amino acids  
 B) Salts  
 C) Ammonia  
 D) Water
- Q.13 Active uptake of \_\_\_\_\_ in the ascending limb or thick loop of Henle is promoted by the action of aldosterone:**  
 A)  $K^+$   
 B)  $Cl^-$   
 C)  $Ca^{++}$   
 D)  $Na^+$
- Q.14 The process through which the body maintains the internal environment from the fluctuations of external environment is called as:**  
 A) Behavior of organisms  
 B) Adaptation  
 C) Thermoregulation  
 D) Homeostasis
- Q.15 Active pumping out of  $Na^+$  occurs at which part of nephron:**  
 A) Proximal tubule  
 B) Descending loop of Henle  
 C) Ascending loop of Henle  
 D) Collecting ducts

## 2014

- Q.16 Which one of the following is responsible for the production of concentrated urine?**  
 A) Juxtamedullary nephrons  
 B) Cortical nephrons  
 C) Proximal tubule  
 D) Distal tubule
- Q.17 Reabsorption of useful constituents normally takes place in which one of the following?**  
 A) Proximal tubule  
 B) Distal tubule  
 C) Bowman's capsule  
 D) Glomerulus
- Q.18 Which one of the following parts of excretory system in humans acts as countercurrent multiplier?**  
 A) Kidney  
 B) Cortex  
 C) Medulla  
 D) Loop of Henle
- Q.19 Anti-Diuretic Hormone (ADH) is released from**  
 A) Anterior pituitary lobe  
 B) Posterior pituitary lobe  
 C) Hypothalamus  
 D) Thalamus
- Q.20 Which one of the following is the main nitrogenous waste product in humans?**  
 A) Urea  
 B) Ammonia  
 C) Salts  
 D) Uric acid

## 2015

- Q.21 Those nephrons which are present along the border of the cortex and medulla are called:**  
 A) Juxtamedullary nephrons  
 B) Cortical nephrons  
 C) Internal nephrons  
 D) Outer nephrons
- Q.22 When water is in short supply, increased water retention occurs through the:**  
 A) Cortical nephrons  
 B) Proximal Convoluted Tubule  
 C) Juxtamedullary nephrons  
 D) The tissue of cortex

- Q.23 In nephrons, counter-current multiplier occurs at:**  
 A) Loop of Henle C) Bowman's Capsule  
 B) Collecting Duct D) Glomerulus
- Q.24 Ascending loop of Henle does not allow outflow of:**  
 A) Na<sup>+</sup> ions C) Cl<sup>-</sup> ions  
 B) K<sup>+</sup> ions D) Water
- Q.25 A larger quantity of dilute urine is produced in diabetes insipidus. This disease is due to the deficiency of:**  
 A) Antidiuretic Hormone C) Thyroxine  
 B) Aldosterone D) Cortisol
- Q.26 Water and sodium ions are reabsorbed in:**  
 A) Urinary Bladder and Urethra C) Adrenal Cortex  
 B) Ureter D) Proximal Convoluted Tubule & Collecting Duct

**2016**

- Q.27 Bowman's capsule continues as extensively convoluted portion known as:**  
 A) Peritubular capillaries C) Efferent arterioles  
 B) Proximal convoluted tubules D) Afferent arterioles
- Q.28 The concentration of sodium ions in body fluids is controlled by the hormone:**  
 A) Renin C) Angiotensin  
 B) Aldosterone D) CPK
- Q.29 A hormone released from posterior pituitary lobe acts to be actively transport water from filtrate is collecting tubules back to kidney is shown as:**  
 A) Renin C) Angiotensin  
 B) Antidiuretic hormone D) Growth Factor
- Q.30 The removal metabolic waste from the blood is called:**  
 A) Thermoregulation C) Kidney Failure  
 B) Osmoregulation D) Excretion
- Q.31 Highly toxic nitrogenous excretory product is:**  
 A) CO<sub>2</sub> C) Urea  
 B) Uric Acid D) Ammonia
- Q.32 Humans have homeostatic thermostat present in a specified portion of the brain that is:**  
 A) Lateral ventricle C) Spinal Cord  
 B) Thalamus D) Hypothalamus

<b>ANSWERS</b>	<b>Q.1</b>	D	<b>Q.9</b>	B	<b>Q.17</b>	A	<b>Q.25</b>	A
	<b>Q.2</b>	C	<b>Q.10</b>	C	<b>Q.18</b>	D	<b>Q.26</b>	D
	<b>Q.3</b>	B	<b>Q.11</b>	A	<b>Q.19</b>	B	<b>Q.27</b>	B
	<b>Q.4</b>	A	<b>Q.12</b>	D	<b>Q.20</b>	A	<b>Q.28</b>	B
	<b>Q.5</b>	D	<b>Q.13</b>	D	<b>Q.21</b>	A	<b>Q.29</b>	B
	<b>Q.6</b>	B	<b>Q.14</b>	D	<b>Q.22</b>	C	<b>Q.30</b>	D
	<b>Q.7</b>	D	<b>Q.15</b>	C	<b>Q.23</b>	A	<b>Q.31</b>	D
	<b>Q.8</b>	A	<b>Q.16</b>	A	<b>Q.24</b>	D	<b>Q.32</b>	D

6D

## NERVOUS SYSTEM

## 2011

- Q.1 Over-activity of sympathetic nervous system causes**  
 A) Disturbance of Vision  
 B) Constipation  
 C) Decrease in Blood Pressure  
 D) Increase in Heart Rate
- Q.2 Which structures respond when they are stimulated by impulse coming through motor neuron?**  
 A) Receptors  
 B) Responses  
 C) Effectors  
 D) Transduction
- Q.3 Respiratory center is located in**  
 A) Cerebrum  
 B) Cerebellum  
 C) Medulla  
 D) Hypothalamus
- Q.4 A neurological condition characterized by involuntary tremors, diminished motor activity and rigidity is called**  
 A) Epilepsy  
 B) Parkinson's Disease  
 C) Alzheimer's Disease  
 D) Cerebular Tumours

## 2012

- Q.5 The part of neuron fibre which conducts nerve impulses from the cell body is**  
 A) Dendron  
 B) Dendrites  
 C) Axon  
 D) Peripheral branch
- Q.6 The number of cranial nerves in human is**  
 A) 31 pairs  
 B) 12 pairs  
 C) 24 pairs  
 D) 62 pairs
- Q.7 The part of brain which controls breathing, heart rate and swallowing is**  
 A) Cerebrum  
 B) Cerebellum  
 C) Medulla  
 D) Hypothalamus
- Q.8 Cause of Parkinson's disease is death of brain cells that produce**  
 A) Dopamine  
 B) Acetylcholine  
 C) ADH hormone  
 D) Oxytocin

## 2013

- Q.9 The structures which respond when they are stimulated by impulse coming through motor neuron are:**  
 A) Receptors  
 B) Responders  
 C) Transducers  
 D) Effectors
- Q.10 Thalamus and cerebrum are the part of:**  
 A) Fore brain  
 B) Mid brain  
 C) Hind brain  
 D) Spinal cord

- Q.11** There is also EVIDENCE that high levels of \_\_\_\_\_ may contribute to the onset of Alzheimer's disease:
- |       |       |
|-------|-------|
| A) Mg | C) Al |
| B) Mo | D) Ca |

- Q.12** L-dopa or Levodopa is used to get some relief from??
- |                        |                        |
|------------------------|------------------------|
| A) Epilepsy            | C) Parkinson's disease |
| B) Alzheimer's disease | D) Dementia            |

**2014**

- Q.13** The right and left cerebral hemispheres are connected by a thick band of nerve fibres called:
- |                    |                |
|--------------------|----------------|
| A) Medulla         | C) Pons        |
| B) Corpus callosum | D) Hippocampus |
- Q.14** The part of the brain which guides smooth and accurate motions and maintains body position is called
- |               |            |
|---------------|------------|
| A) Cerebrum   | C) Pons    |
| B) Cerebellum | D) Medulla |
- Q.15** Which one of the following is the effect of sympathetic nervous system?
- |                            |                                      |
|----------------------------|--------------------------------------|
| A) Constriction of bronchi | C) Promotes digestion or peristalsis |
| B) Decrease in heart rate  | D) Dilates the pupil                 |
- Q.16** High levels of aluminium may contribute to the onset of which one of the following?
- |                        |                        |
|------------------------|------------------------|
| A) Parkinson's disease | C) Alzheimer's disease |
| B) Epilepsy            | D) Gonorrhoea          |

**2015**

- Q.17** Which disease is responsible for dementia (memory loss)?
- |                        |                    |
|------------------------|--------------------|
| A) Parkinson's Disease | C) Epilepsy        |
| B) Alzheimer's Disease | D) Grave's Disease |
- Q.18** Neurotransmitter secreted at synapse outside the central nervous system is:
- |                |                  |
|----------------|------------------|
| A) Dopamine    | C) Androgen      |
| B) Polypeptide | D) Acetylcholine |
- Q.19** Conduction of action potentials from one node of Ranvier to another in myelinated neurons is through:
- |                               |                         |
|-------------------------------|-------------------------|
| A) Hyperpolarization          | C) Depolarization       |
| B) Resting Membrane Potential | D) Saltatory Conduction |
- Q.20** In the following diagram of action potential in a neuron, 'x' depicts:

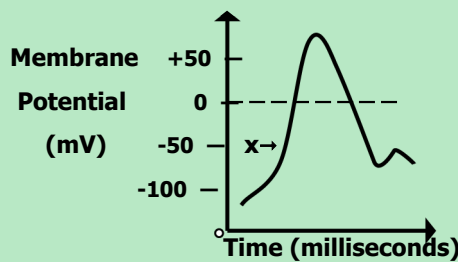

- |                   |                      |
|-------------------|----------------------|
| A) Depolarization | C) Repolarization    |
| B) Polarization   | D) Hyperpolarization |

## 2016

- Q.21** Random, uncontrolled activity of some cells in the brain leading to chaotic activity in both sensory and motor nerves causes patients of to see and hear different strange things.  
 A) Epilepsy  
 B) Parkinson's Disease  
 C) Alzheimer's Disease  
 D) Huntington's Disease
- Q.22** Part of hind brain responsible for the balance and equilibrium of body is called:  
 A) Medulla  
 B) Cerebellum  
 C) Pons  
 D) Thalamus
- Q.23** The disease in which death of small number of cells in the basal ganglia leads to inability to select and initiate patterns of movement is known as:  
 A) Fever  
 B) Alzheimer's Disease  
 C) Epilepsy  
 D) Parkinson's Disease
- Q.24** A neurological disorder characterized by the decline in brain function is \_\_\_\_\_. Its symptoms are similar to those diseases that cause dementia.  
 A) Parkinson's Disease  
 B) Epilepsy  
 C) Alzheimer's Disease  
 D) Diabetes
- Q.25** A discharge by brain which causes chaotic activity in motor and sensory areas is:  
 A) Meningitis  
 B) Alzheimer's Disease  
 C) Epilepsy  
 D) Parkinson's Disease

<b>ANSWERS</b>	Q.1	D	Q.8	A	Q.15	D	Q.22	B
	Q.2	C	Q.9	D	Q.16	C	Q.23	D
	Q.3	C	Q.10	A	Q.17	B	Q.24	C
	Q.4	B	Q.11	C	Q.18	D	Q.25	C
	Q.5	C	Q.12	C	Q.19	D		
	Q.6	B	Q.13	B	Q.20	A		
	Q.7	C	Q.14	B	Q.21	A		

## 6E

## REPRODUCTION

## 2011

- Q.1 A type of cell in human testes which produces testosterone is called**  
 A) Interstitial Cells C) Sertoli Cells  
 B) Germ Cells D) Spermatocytes
- Q.2 Breakdown of endometrium during menstruation is due to**  
 A) Increase in Level of LH C) Increase in Level of Progesterone  
 B) Decrease in Level of Progesterone D) Increase in Level of Oestrogen
- Q.3 Oogonia are produced in the germ cells**  
 A) Both Uterus and Cervix C) Uterus  
 B) Cervix D) Ovary
- Q.4 Luteinizing hormone triggers**  
 A) Cessation of Oogenesis C) Ovulation  
 B) Breakdown of Oocyte D) Development of Zygote
- Q.5 Syphilis is a sexually transmitted disease which is caused by**  
 A) HIV / AIDS C) Treponema Pallidum  
 B) Pseudomonas Pyogenes D) Neisseria

## 2012

- Q.6 Syphilis is a sexually transmitted disease which is caused by**  
 A) Neisseria gonorrhoeae C) Treponema pallidum  
 B) E. coli D) Mycobacterium avium
- Q.7 Discharge of ovum or secondary oocyte from ovary or from Graafian follicle is called**  
 A) Fertilization C) Follicle formation  
 B) Pollination D) Ovulation
- Q.8 Second meiotic division in the secondary oocyte proceeds as far as**  
 A) Metaphase C) Anaphase  
 B) Prophase D) Telophase
- Q.9 Which one of the following differentiates directly into mature sperm?**  
 A) Primary spermatocyte C) Spermatogonia  
 B) Secondary spermatocyte D) Spermatid
- Q.10 Uterus opens into the vagina through**  
 A) Cervix C) External genitalia  
 B) Fallopian tube D) Vulva



## 2013

- Q.11 Spermatogonia differentiate directly into?**  
 A) Primary spermatocytes  
 B) Secondary spermatocytes  
 C) Spermatozoa  
 D) Spermatids
- Q.12 Treponema palladium causes?**  
 A) AIDS  
 B) Genital herpes  
 C) Syphilis  
 D) Gonorrhoea
- Q.13 What is the location of interstitial cells in testes?**  
 A) Inside the seminiferous tubules  
 B) Between the seminiferous tubules  
 C) Among the germinal epithelial cells  
 D) Around the testes
- Q.14 A type of cells in human testes which produce testosterone are called?**  
 A) Germ cells  
 B) Sertoli cells  
 C) Interstitial cells  
 D) Spermatocytes
- Q.15 The hormone produced from corpus luteum is:**  
 A) Prolactin  
 B) FSH  
 C) Progesterone  
 D) LH

## 2014

- Q.16 Testosterone is produced by which one of the following?**  
 A) Sertoli cells  
 B) Germinal epithelium  
 C) Interstitial cells  
 D) Spermatogonia
- Q.17 The oocyte released during ovulation is in**  
 A) Anaphase I  
 B) Prophase I  
 C) Metaphase I  
 D) Metaphase II
- Q.18 Yellowish glandular structure formed after the release of egg from follicle is called**  
 A) Corpus callosum  
 B) Graafian follicle  
 C) Corpus luteum  
 D) Follicle atresia
- Q.19 On puberty, the development of primary follicles is stimulated by**  
 A) ICSH  
 B) FSH  
 C) LH  
 D) Estrogen
- Q.20 Causative agent of a sexually transmitted disease that affects mucous membrane of the urinogenital tract is**  
 A) Staphylococcus aureus  
 B) Treponema pallidum  
 C) Neisseria gonorrhoeae  
 D) Escherichia coli

## 2015

- Q.21 In human testis, which structure is responsible for carrying sperm from inside the testis?**  
 A) Seminiferous tubules  
 B) Urinogenital duct  
 C) Seminal Vesicles  
 D) Vasa efferentia
- Q.22 In which part of female reproductive system fertilization takes place?**  
 A) Proximal part of oviduct  
 B) Uterus  
 C) Placenta  
 D) Vagina
- Q.23 In females, FSH stimulates the ovary to produce:**  
 A) Progesterone  
 B) Lactin  
 C) Oestrogen  
 D) Oxytocin

- Q.24 Syphilis, sexually transmitted disease is caused by:**  
 A) HIV  
 B) Treponema pallidum  
 C) Neisseria gonorrhoeae  
 D) Type '2' virus
- Q.25 In which phase of human female menstrual cycle, endometrium prepares for the implantation of embryo?**  
 A) Proliferative phase  
 B) Menstrual phase  
 C) Secretory phase  
 D) Ovulation phase

## 2016

- Q.26 Events of menstrual cycle are regulated by the:**  
 A) Ethylene  
 B) Gonadotrophins  
 C) Auxins  
 D) Gibberellins
- Q.27 Decrease of FSH and increase of estrogen cause pituitary gland to secrete:**  
 A) Somatotropin  
 B) Luteinizing Hormone  
 C) Testosterone  
 D) Spermatogonium
- Q.28 Transmission of Neisseria gonorrhoea is best described by which one of the following?**  
 A) Oro-fecal Route  
 B) Unsafe Sex  
 C) Vector Borne  
 D) Droplet Infection
- Q.29 Syphilis is caused by:**  
 A) Spirochete  
 B) Nostoc  
 C) Water blooms  
 D) Cyanobacteria
- Q.30 AIDS is caused by:**  
 A) Bacteria  
 B) Virus  
 C) Fungi  
 D) Alga

<b>ANSWERS</b>	<b>Q.1</b>	A	<b>Q.9</b>	D	<b>Q.17</b>	D	<b>Q.25</b>	C
	<b>Q.2</b>	B	<b>Q.10</b>	A	<b>Q.18</b>	C	<b>Q.26</b>	B
	<b>Q.3</b>	D	<b>Q.11</b>	A	<b>Q.19</b>	B	<b>Q.27</b>	B
	<b>Q.4</b>	C	<b>Q.12</b>	C	<b>Q.20</b>	C	<b>Q.28</b>	A
	<b>Q.5</b>	C	<b>Q.13</b>	B	<b>Q.21</b>	D	<b>Q.29</b>	A
	<b>Q.6</b>	C	<b>Q.14</b>	C	<b>Q.22</b>	A	<b>Q.30</b>	B
	<b>Q.7</b>	D	<b>Q.15</b>	C	<b>Q.23</b>	C		
	<b>Q.8</b>	A	<b>Q.16</b>	C	<b>Q.24</b>	B		

## 6F

## SUPPORT AND MOVEMENT

## 2011

- Q.1 Muscle is made up of many cells which are referred to as**  
 A) Myofilaments  
 B) Myofibrils  
 C) Sarcolemma  
 D) Muscles Fiber
- Q.2 The length of myofibril from one Z-band to the next is known as**  
 A) Sarcomere  
 B) Sarcolemma  
 C) Sarcoplasm  
 D) Muscle Fiber
- Q.3 Calcium ions released during a muscle fiber contraction attach with**  
 A) Myosin  
 B) Actin  
 C) Tropomyosin  
 D) Troponin
- Q.4 A muscle condition resulting from the accumulation of lactic acid and ionic imbalance is:**  
 A) Tetany  
 B) Muscle Fatigue  
 C) Cramp  
 D) Tetanus
- Q.5 The pigment which stores oxygen in muscles is**  
 A) Hemoglobin  
 B) Myoglobin  
 C) Myosin  
 D) Actinomyosin

## 2012

- Q.6 Each muscle fibre is surrounded by membrane which is called**  
 A) Sarcomere  
 B) Sarcolemma  
 C) Twitch fibre  
 D) Capsule
- Q.7 When calcium ions are released from the sarcoplasmic reticulum they bind with \_\_\_\_\_ during muscle contraction**  
 A) Tropomyosin  
 B) Sarcolemma  
 C) Cytosol's ions  
 D) Troponin
- Q.8 Human and mammalian skeleton can be divided into two parts, axial skeleton and**  
 A) Appendicular skeleton  
 B) Exoskeleton  
 C) Endoskeleton  
 D) Hydrostatic skeleton
- Q.9 Last four vertebrae in humans are fused to form a structure called**  
 A) Sacrum  
 B) Cervical vertebrae  
 C) Pubis  
 D) Coccyx
- Q.10 How many bones are involved in the formation of each half of pelvic girdle?**  
 A) 3 bones  
 B) 4 bones  
 C) 2 bones  
 D) 1 bone

## 2013

- Q.11 The length of myofibril from one Z-band to the next is described as:**  
 A) Sarcolemma C) Sarcomere  
 B) Sarcoplasm D) Muscle fiber
- Q.12 The  $\text{Ca}^{++}$  ions released during a muscle fiber contraction attach with:**  
 A) Myosin C) Troponin  
 B) Actin D) Tropomyosin
- Q.13 The joint that allows the movement in several directions is called:**  
 A) Hinge joint C) Cartilaginous joint  
 B) Ball and Socket joint D) Fibrous joint
- Q.14 Where can we find H zone in the figure of fine structure of skeletal muscle's myofibril?**  
 A) In the mid of A band C) Besides the Z-line  
 B) In I-band D) Along the I-band
- Q.15 First vertebra of cervical region of vertebral column is known as:**  
 A) Atlas C) Thoracic  
 B) Sacral D) Axis

## 2014

- Q.16 In a human vertebral column, the number of \_\_\_\_\_ vertebrae is 7.**  
 A) Cervical C) Lumbar  
 B) Thoracic D) Sacrum
- Q.17 Which one of the following structures holds the bones together?**  
 A) Joints C) Fibrous capsules  
 B) Cartilages D) Ligaments
- Q.18 Which one of the following cartilages is the most abundant in the human body?**  
 A) Elastic cartilage C) Fibrous Cartilage  
 B) Chondrous cartilage D) Hyaline Cartilage
- Q.19 The repeated protein pattern of myofibrils is called**  
 A) Sarcomere C) Sarcolemma  
 B) Zyomere D) Cross bridges
- Q.20 When more energy is required in muscle contraction then that energy can also be produced by \_\_\_\_\_ as a secondary source.**  
 A) Glucose C) Fructose  
 B) Phosphocreatine D) Lactic acid

## 2015

- Q.21 The total number of cervical and thoracic vertebrae in human vertebral column is:**  
 A) 7 C) 14  
 B) 19 D) 33
- Q.22 A sarcomere is the region of a myofibril between two successive:**  
 A) M-lines C) I-bands  
 B) Z-lines D) T-tubules

- Q.23 The sarcolemma of muscle fibre folds inwards and forms a system of tubes which runs through the sarcoplasm called:**  
 A) Myofilaments  
 B) Sarcoplasmic reticulum  
 C) Z-lines  
 D) Transverse tubules
- Q.24 According to sliding filament theory, when muscle fibers are stimulated by nervous system, which of the following changes occurs?**  
 A) I-bands shorten  
 B) H-zone becomes more visible  
 C) Z-lines move further apart  
 D) A-bands shorten
- Q.25 If lactic acid build up in thigh muscles, it causes muscle tiredness and pain. This condition is called:**  
 A) Muscle Fatigue  
 B) Tetany  
 C) Cramps  
 D) Oxygen debt in muscles

**2016**

- Q.26 Brain is protected and enclosed in:**  
 A) Lumbar vertebrae  
 B) Coccyx  
 C) Vertebral column  
 D) Cranium
- Q.27 Longest bone in the human skeleton is:**  
 A) Ulna  
 B) Fibula  
 C) Tibia  
 D) Femur
- Q.28 Hips and shoulder joints are examples of:**  
 A) Hinge Joints  
 B) Ball and Socket Joints  
 C) Synovial Joints  
 D) Cartilaginous Joints
- Q.29 In pelvic region of human body, sacrum is formed by the fusion of:**  
 A) 4 Vertebrae  
 B) 5 Vertebrae  
 C) 6 Vertebrae  
 D) 3 Vertebrae
- Q.30 Each muscle fibre is surrounded by a modified cell membrane called:**  
 A) Sarcolemma  
 B) Sarcomere  
 C) Myosin Filament  
 D) Myofilament

<b>ANSWERS</b>	<b>Q.1</b>	D	<b>Q.9</b>	D	<b>Q.17</b>	D	<b>Q.25</b>	A
	<b>Q.2</b>	A	<b>Q.10</b>	A	<b>Q.18</b>	D	<b>Q.26</b>	D
	<b>Q.3</b>	D	<b>Q.11</b>	C	<b>Q.19</b>	A	<b>Q.27</b>	D
	<b>Q.4</b>	B	<b>Q.12</b>	C	<b>Q.20</b>	B	<b>Q.28</b>	B
	<b>Q.5</b>	B	<b>Q.13</b>	B	<b>Q.21</b>	B	<b>Q.29</b>	B
	<b>Q.6</b>	B	<b>Q.14</b>	A	<b>Q.22</b>	B	<b>Q.30</b>	A
	<b>Q.7</b>	D	<b>Q.15</b>	A	<b>Q.23</b>	D		
	<b>Q.8</b>	A	<b>Q.16</b>	A	<b>Q.24</b>	A		

## 6G

## HORMONAL CONTROL

## 2011

- Q.1 Neurosecretory cells are present in which part of brain**  
 A) Hypothalamus  
 B) Midbrain  
 C) Pons  
 D) Cerebellum
- Q.2 Which of the following is the function of glucagon hormone?**  
 A) Glycogen to Glucose  
 B) Glucose to Glycogen  
 C) Glucose to Lipids  
 D) Glucose to Proteins
- Q.3 Addison's disease is caused due to destruction of**  
 A) Adrenal Cortex  
 B) Pituitary Adrenal Axis  
 C) Adrenal Medulla  
 D) Hypothalamus
- Q.4 Which group of hormones is made up of amino acids and their derivatives?**  
 A) Vasopressin and ADH  
 B) Epinephrine and Non-Epinephrine  
 C) Oestrogen and Testosterone  
 D) Insulin and Glucagon

## 2012

- Q.5 Ductless glands are known as**  
 A) Endocrine gland  
 B) Exocrine gland  
 C) Salivary glands  
 D) Bile glands
- Q.6 Gastrin is the hormone which is produced by the**  
 A) Liver  
 B) Pyloric region of stomach  
 C) Adrenal gland  
 D) Mucosal lining of intestine
- Q.7  $\beta$ -cells of liver secrete a hormone that is called**  
 A) Insulin  
 B) Glucagon  
 C) Antidiuretic hormone  
 D) Gastrin
- Q.8 Vasopressin and Oxytocin are released from the**  
 A) Placenta  
 B) Ovary  
 C) Anterior pituitary  
 D) Posterior pituitary

## 2013

- Q.9 Chemically insulin and glucagon are:**  
 A) Carbohydrates  
 B) Proteins  
 C) Lipids  
 D) Nucleic acids
- Q.10 Hormones secreted by anterior pituitary and which controls the secretion of hormones of other endocrine glands are known as:**  
 A) Release factor  
 B) Inhibitor  
 C) Accelerator  
 D) Tropic or trophic hormones

**Q.11 Alpha cells of Islets of Langerhans secrete hormone called:**

- A) Glucocorticoid  
B) Insulin  
C) Glucagon  
D) Aldosterone

**Q.12 Which of the following is the function of glucagon hormone?**

- A) Glucose to lipids  
B) Glucose to proteins  
C) Glucose to glycogen  
D) Glycogen to glucose

## 2014

**Q.13 Which one of the following is a steroid hormone?**

- A) Glucagon  
B) Thyroxine  
C) Epinephrine  
D) Oestrogen

**Q.14 The gonadotrophic hormones of anterior lobe of pituitary include:**

- A) Prolactin, Thyroid Stimulating Hormone, Somatotropin Hormone  
B) Follicle Stimulating Hormone, Luteinizing Hormone, Prolactin  
C) Adrenocorticotrophic Hormone, Luteinizing Hormone, Follicle Stimulating Hormone  
D) Luteinizing Hormone, Follicle Stimulating Hormone, Thyroid Stimulating Hormone

**Q.15 Over-activity of cortical hormone of adrenal gland causes**

- A) Addison's disease  
B) Parkinson's disease  
C) Cushing's disease  
D) Down's syndrome

**Q.16 How many iodine atoms are present in thyroxine?**

- A) 3  
B) 4  
C) 2  
D) 5

## 2015

**Q.17 Thyroxine deficiency in adults' results in a condition called:**

- A) Cretinism  
B) Hypothyroidism  
C) Thyrotoxicosis  
D) Myxoedema

**Q.18  $\alpha$ -cells of pancreas secrete a hormone known as:**

- A) Glucagon  
B) Insulin  
C) Gastrin  
D) Rennin

**Q.19 Over-secretion of cortical hormone causes a disease called;**

- A) Cushing's Disease  
B) Diabetes Mellitus  
C) Hypoglycemia  
D) Addison's Disease

**Q.20 Ejection of milk from mammary glands is under the control of which one of the following hormones?**

- A) Androgen  
B) Oxytocin  
C) Progesterone  
D) Estrogen

## 2016

**Q.21 \_\_\_\_\_ hormone is antagonistic to insulin and causes increase in blood glucose level.**

- A) Glucagon  
B) Nor-epinephrine  
C) Calcitonin  
D) Thyroxine

**Q.22 Beta cells of islets of Langerhans produce \_\_\_\_\_ hormone.**

- A) Glucagon  
B) Insulin  
C) Pancreatic Juice  
D) Parathormone

**Q.23** The central portion of adrenal gland (Adrenal Medulla) produces \_\_\_\_\_ hormone.

- A) Aldosterone  
 B) Epinephrine  
 C) Androgen  
 D) Corticosterone

**Q.24** \_\_\_\_\_ hormones are called fight and flight hormones as they prepare an organism to face stressful situation.

- A) Adrenaline, Aldosterone  
 B) Epinephrine, Nor-epinephrine  
 C) Cortisone, Oxytocin  
 D) Thyroxine, Nor-epinephrine

<b>ANSWERS</b>	<b>Q.1</b>	A	<b>Q.8</b>	D	<b>Q.15</b>	C	<b>Q.22</b>	B
	<b>Q.2</b>	A	<b>Q.9</b>	B	<b>Q.16</b>	A	<b>Q.23</b>	B
	<b>Q.3</b>	A	<b>Q.10</b>	D	<b>Q.17</b>	D	<b>Q.24</b>	B
	<b>Q.4</b>	B	<b>Q.11</b>	C	<b>Q.18</b>	A		
	<b>Q.5</b>	A	<b>Q.12</b>	D	<b>Q.19</b>	A		
	<b>Q.6</b>	C	<b>Q.13</b>	D	<b>Q.20</b>	B		
	<b>Q.7</b>	X	<b>Q.14</b>	B	<b>Q.21</b>	A		

 The logo for ARK, featuring the letters 'A', 'R', and 'K' in a stylized, rounded font. The 'A' is a large, light blue shape with a white swoosh underneath it. The 'R' and 'K' are also light blue and rounded.





## IMMUNITY

### 2011

- Q.1 Thymus gland is involved in maturation of**  
 A) Platelets  
 B) B-Lymphocytes  
 C) Eosinophils  
 D) T-Lymphocytes
- Q.2 In passive immunity which of the following component are injected into blood**  
 A) Antigens  
 B) Immunogens  
 C) Serum  
 D) Immunoglobulins
- Q.3 Mucous membranes are part of body defense system and they offer**  
 A) Physical Barriers  
 B) Mechanical Barriers  
 C) Chemical Barriers  
 D) Biological Barriers
- Q.4 Immediate protection is obtained from**  
 A) Passive Immunity  
 B) Active Immunity  
 C) Vaccination  
 D) Natural Activity Immunity
- Q.5 The immunity in which T-cells recognize the antigens or micro-organisms is known as**  
 A) Tissue Grafting  
 B) Phagocytosis  
 C) Cell Mediated Immunity / Response  
 D) Hormonal Immunity / Response

### 2012

- Q.6 Antigen is a foreign protein or any other molecule which stimulates the formation of**  
 A) MHC complex  
 B) Immunogen  
 C) Mucus  
 D) Antibodies
- Q.7 Antibodies are produced by which of the following lymphocytes?**  
 A) B lymphocytes  
 B) A lymphocytes  
 C) T lymphocytes  
 D) B and T lymphocytes
- Q.8 T-lymphocytes become mature and competent under the influence of**  
 A) Liver  
 B) Bursa of fabricius  
 C) Thymus gland  
 D) Spleen
- Q.9 Skin and mucous membranes are part of the body defense system and they form the**  
 A) Physical barrier  
 B) Mechanical barriers  
 C) Chemical barriers  
 D) Biological barriers
- Q.10 Snake bite is treated with which type of immunization?**  
 A) Active  
 B) Passive  
 C) Humoral  
 D) Specific

## 2013

- Q.11 In passive immunity which of the following components are injected into body?**  
 A) Antigens  
 B) Immunogens  
 C) Serum  
 D) Immunoglobulins
- Q.12 Which part of the antibody recognizes the antigen during immune response?**  
 A) Heavy part  
 B) Variable part  
 C) Light part  
 D) Consonant part
- Q.13 Two identical light chains and two identical heavy chains in antibody molecule are linked by:**  
 A) Disulphide bridges  
 B) Peptide bond  
 C) Glycerol bond  
 D) Ionic bond
- Q.14 Antibodies are produced against invading cells by:**  
 A) Lymphocytes  
 B) Basophils  
 C) Basophils  
 D) Neutrophils
- Q.15 In the structural diagram of an antibody molecule which portion is occupied by variable chains?**  
 A) Lower region  
 B) Upper region  
 C) Middle region  
 D) In between chains

## 2014

- Q.16 T-lymphocytes recognize antigen and attack microorganisms or transplanted organ and tissues. This effect is called**  
 A) Cell-mediated response  
 B) Humeral immune response  
 C) Active immunity  
 D) Passive immunity
- Q.17 Which part of antibody recognizes the antigen during immune response?**  
 A) Heavy part  
 B) Light part  
 C) Constant part  
 D) Variable part
- Q.18 What type of immunity is achieved by injecting antibodies, antiserum, anti-venom serum?**  
 A) Active immunity  
 B) Passive immunity  
 C) Artificially induced immunity  
 D) Naturally induced immunity
- Q.19 Which one of the following glands is involved in the production of lymphocytes?**  
 A) Pineal  
 B) Pituitary  
 C) Thymus  
 D) Adrenal
- Q.20 Antibodies are proteins and made up of how many polypeptide chains?**  
 A) One  
 B) Two  
 C) Three  
 D) Four

## 2015

- Q.21 In \_\_\_\_\_ response,  $\beta$ -cells produce plasma cells that synthesize antibodies and release in blood plasma and tissue fluid.**  
 A) Cell-Mediated  
 B) Hormonal  
 C) Humoral  
 D) Phototactic
- Q.22 Passive immunity is used against:**  
 A) Malaria  
 B) Typhoid  
 C) Dengue  
 D) Tetanus

- Q.23 B-lymphocytes are named due to their relationship with:**  
 A) Blood  
 B) Bursa of Fabricius  
 C) Bone Marrow  
 D) Bile Duct
- Q.24 Granulocytes are:**  
 A) Monocytes, Eosinophils, Basophils  
 B) Basophils, Macrophages, Neurophils  
 C) Neurophils, Eosinophils, Basophils  
 D) Monocytes, Macrophages, Basophils
- Q.25 Response of body against the transplanted organ is:**  
 A) Homeostatic Response  
 B) Behavioral Response  
 C) Primary Response  
 D) Cell-mediated Response

## 2016

- Q.26 B-cells release antibodies in blood plasma, tissue fluid and lymph. This kind of immune response is called:**  
 A) Cell Mediated Response  
 B) Humoral Response  
 C) Active Response  
 D) Compound Response
- Q.27 The type of immunity in which antibodies are passed from one individual to another is called:**  
 A) Passive Immunity  
 B) Artificial Active Immunity  
 C) Natural Active Immunity  
 D) Humoral Immunity
- Q.28 To combat the active infections of tetanus, rabies and snakes the \_\_\_\_\_ method of immunization is used:**  
 A) Active  
 B) Humoral  
 C) Active Artificial  
 D) Passive
- Q.29 In antibody molecule, two heavy and two light chains are bonded by:**  
 A) Disulphide Bond  
 B) Monosulphide Bond  
 C) Hydrogen Bond  
 D) Ionic Bond
- Q.30 Variable amino acid sequences in antibody molecule are found in \_\_\_\_\_.**  
 A) Both light chains only  
 B) Both heavy chains only  
 C) One heavy and one light chain  
 D) Both heavy and light chains

<b>ANSWERS</b>	<b>Q.1</b>	D	<b>Q.9</b>	A	<b>Q.17</b>	D	<b>Q.25</b>	D
	<b>Q.2</b>	D	<b>Q.10</b>	B	<b>Q.18</b>	B	<b>Q.26</b>	B
	<b>Q.3</b>	A	<b>Q.11</b>	D	<b>Q.19</b>	C	<b>Q.27</b>	A
	<b>Q.4</b>	A	<b>Q.12</b>	B	<b>Q.20</b>	D	<b>Q.28</b>	D
	<b>Q.5</b>	C	<b>Q.13</b>	A	<b>Q.21</b>	C	<b>Q.29</b>	A
	<b>Q.6</b>	D	<b>Q.14</b>	A	<b>Q.22</b>	D	<b>Q.30</b>	D
	<b>Q.7</b>	A	<b>Q.15</b>	B	<b>Q.23</b>	B		
	<b>Q.8</b>	C	<b>Q.16</b>	B	<b>Q.24</b>	C		

## 7

## BIOENERGETICS

## 2011

- Q.1 Oxidative phosphorylation, synthesis of ATP in the presence of oxygen occurs in:**  
 A) All Types of Cells  
 B) All Anaerobic Cells  
 C) All Primitive Cells  
 D) All Aerobic Cells
- Q.2 Glycolysis is the breakdown of glucose into two molecules of**  
 A) Glycerate  
 B) Lactic Acid  
 C) Pyruvate  
 D) Succinic Acid
- Q.3 Before entering Krebs's cycle, the pyruvate is first decarboxylated and oxidized into**  
 A) Alpha Ketoglutaric Acid  
 B) Citric Acid  
 C) Glyceric Acid  
 D) Acetic Acid
- Q.4 Some electron from the second primary acceptor may pass back to chlorophyll molecules by electron carrier system, yielding ATP. This process is called**  
 A) Phosphorylation  
 B) Photophosphorylation  
 C) Non-Cyclic Phosphorylation  
 D) Cyclic Phosphorylation
- Q.5 Z-scheme is used for**  
 A) Non-Cyclic Photophosphorylation  
 B) Cyclic Photophosphorylation  
 C) Both Cyclic and Non-Cyclic Photophosphorylation  
 D) Oxidative Phosphorylation

## 2012

- Q.6 The product(s) of cyclic photophosphorylation is / are:**  
 A) ATP  
 B) NADP  
 C) NADP and ATP  
 D) NADP, ATP, and O<sub>2</sub>
- Q.7 Total NADH formed by one glucose molecule during Krebs's Cycle are**  
 A) 6  
 B) 3  
 C) 8  
 D) 18
- Q.8 The terminal electron acceptor in electron transport chain is**  
 A) Hydrogen  
 B) Iron  
 C) Cytochrome  
 D) Oxygen
- Q.9 The end product of glycolysis is**  
 A) ADP  
 B) Reduced FAD  
 C) Citric acid  
 D) Pyruvate
- Q.10 One molecule of FADH<sub>2</sub> is produced in Krebs's cycle during conversion of**  
 A) Fumarate Malate  
 B) Succinate Fumarate  
 C) Malate Oxaloacetate  
 D)  $\alpha$ -Ketoglutarate Succinate

## 2013

- Q.11 Every molecule of NADH, fed into ETC produces:**  
 A) 2 ATP  
 B) 3 ATP  
 C) 4 ATP  
 D) 6 ATP
- Q.12 Final acceptor of electrons in respiratory chain is:**  
 A) Cytochrome a  
 B) Oxygen  
 C) Cytochrome a<sup>3</sup>  
 D) Cytochrome c
- Q.13 The end product of anaerobic respiration in humans and other mammals is:**  
 A) Pyruvic acid  
 B) Ethanol  
 C) Lactic acid  
 D) Glucose
- Q.14 A biochemical process which occurs within a cell to breakdown complex compounds to produce energy is called:**  
 A) Respiration  
 B) Photosynthesis  
 C) Oxidation reduction  
 D) Photophosphorylation
- Q.15 Which part of chlorophyll molecule absorbs light?**  
 A) Phytol  
 B) Porphyrin ring  
 C) Pyrrole  
 D) Thylakoid membrane

## 2014

- Q.16 Oxidative phase of glycolysis starts with dehydrogenation of**  
 A) Glycolysis  
 B) Ribulose Bisphosphate  
 C) Glyceraldehyde 3-phosphate  
 D) NADH
- Q.17 In one turn, the Krebs's cycle produces one molecule of ATP, one molecule of FADH<sub>2</sub> and \_\_\_\_\_ molecules of NADH**  
 A) 1  
 B) 2  
 C) 3  
 D) 4
- Q.18 Which one of the following is the stage of cellular respiration for which oxygen is not essential?**  
 A) Glycolysis  
 B) Pyruvate oxidation  
 C) Krebs's cycle  
 D) Electron Transport Chain
- Q.19 Pyruvate, the end product of glycolysis moves from cytosol to mitochondrial matrix where it is oxidized into \_\_\_\_\_ producing CO<sub>2</sub> as a by-product.**  
 A) Acetic acid (active)  
 B) Citrate  
 C) NAD  
 D) FAD
- Q.20 Pyruvate**  $\xrightarrow{\quad}$  **Acetyl CoA**  
  
 A)  $\text{FAD}^+ \rightarrow \text{FADH}$   
 B)  $\text{NAD}^+ \rightarrow \text{NADH}$   
 C)  $\text{NADH} \rightarrow \text{NAD} + \text{H}^+$   
 D)  $\text{FADH}^+ \rightarrow \text{FAD} + \text{H}^+$

## 2015

- Q.21 In light independent stage of photosynthesis, the CO<sub>2</sub> combines with \_\_\_\_\_ to form an unstable 6-carbon intermediate.**  
 A) Ribulose bisphosphate  
 B) Hexose sugar  
 C) Glycerate-3-phosphate  
 D) Glyceraldehyde-9-phosphate

- Q.22** In glycolysis, glycerate-1,3-bisphosphate is converted into glycerate-3-phosphate by losing \_\_\_\_\_ phosphate molecules.  
 A) 3  
 B) 2  
 C) 1  
 D) 4
- Q.23** Malate is oxidized by \_\_\_\_\_ to oxaloacetate in Krebs's Cycle.  
 A) ATP  
 B) NADP  
 C) NAD  
 D) FAD
- Q.24** In electron transport chain, the electrons from NADH and FADH<sub>2</sub> are passed to;  
 A) Cytochrome a  
 B) Cytochrome a<sub>3</sub>  
 C) Co-enzyme c  
 D) Co-enzyme Q
- Q.25** Carriers of the respiratory chain are located on:  
 A) Matrix of mitochondria  
 B) Outer membrane of mitochondria  
 C) Inner membrane of mitochondria  
 D) Cytoplasmic matrix

## 2016

- Q.26** Each \_\_\_\_\_ consists of a light gathering antenna complex and reaction center.  
 A) Chlorophyll  
 B) Photosystem  
 C) Photon  
 D) Electron
- Q.27** Photosystem I has chlorophyll a molecules which absorb maximum light of:  
 A) 680 nm  
 B) 780 nm  
 C) 700 nm  
 D) 580 nm
- Q.28** Cyclic flow or C<sub>4</sub> photosynthesis produces:  
 A) ATP and CO<sub>2</sub>  
 B) ATP  
 C) Only CO<sub>2</sub>  
 D) Only Oxygen
- Q.29** Immediate product formed after CO<sub>2</sub> fixation in Calvin Cycle is:  
 A) Unstable 6-carbon compound  
 B) Unstable 5-carbon compound  
 C) Unstable 4-carbon compound  
 D) Unstable 3-carbon compound m
- Q.30** Functional group of chlorophyll a is:  
 A) —CH<sub>3</sub>  
 B) —CHO  
 C) —COOH  
 D) —OH

ANSWERS	Q.1	C	Q.9	D	Q.17	C	Q.25	C
	Q.2	C	Q.10	B	Q.18	A	Q.26	B
	Q.3	D	Q.11	B	Q.19	A	Q.27	C
	Q.4	D	Q.12	B	Q.20	B	Q.28	B
	Q.5	A	Q.13	C	Q.21	A	Q.29	A
	Q.6	A	Q.14	C	Q.22	C	Q.30	A
	Q.7	A	Q.15	B	Q.23	C		
	Q.8	D	Q.16	C	Q.24	D		

## 8

## BIOTECHNOLOGY

## 2011

- Q.1 Prosomes are used in gene therapy against**  
 A) Hypercholesterolemia  
 B) Coronary Artery Angioplasty  
 C) Cystic Fibrosis  
 D) Severe Combined Immunodeficiency Syndrome (SCID)
- Q.2 Genetically engineered cells are introduced into bone marrow cells in the treatment of**  
 A) Hypercholesterolemia  
 B) Severe Combined Immunodeficiency Syndrome (SCID)  
 C) Cystic Fibrosis  
 D) Coronary Artery Angioplasty
- Q.3 The common vectors used in recombinant DNA technology are**  
 A) Probes  
 B) Palindromes  
 C) Plasmids  
 D) Prions
- Q.4 The enzyme used to isolate gene from DNA is**  
 A) Helicase  
 B) Reverse Transcriptase  
 C) Restriction Enzyme  
 D) DNA Polymerase
- Q.5 Which one of the following enzymes is temperature insensitive?**  
 A) DNA Polymerase I  
 B) Taq Polymerase  
 C) DNA Polymerase III  
 D) RNA Polymerase

## 2012

- Q.6 In recombinant DNA technology \_\_\_\_\_ are tools for manipulating DNA**  
 A) Viruses  
 B) Chromosomes  
 C) Enzymes  
 D) Genes
- Q.7 In DNA finger printing process, the use of \_\_\_\_\_ produces distinctive pattern on autoradiography or X-ray film**  
 A) Restriction enzyme  
 B) Microsatellites  
 C) Macrosatellites  
 D) Probes for genetic markers
- Q.8 In the recombinant DNA technology plasmids are used as**  
 A) Genetic material  
 B) Enzymes  
 C) Vectors  
 D) Probes
- Q.9 In which process, multiple copies of the desired genes are produced?**  
 A) Polymerase chain reaction  
 B) Gene sequencing  
 C) Analyzing DNA  
 D) DNA finger printing
- Q.10 The enzyme adenosine deaminase is missing in person suffering from:**  
 A) Cystic fibrosis  
 B) Hypercholesterolemia  
 C) Severe combined immunodeficiency syndrome  
 D) Parkinson's disease

## 2013

- Q.11 The DNA molecule formed from messenger-RNA by reverse transcriptase is called??**  
 A) Complementary DNA  
 B) Recombinant DNA  
 C) Chimeric DNA  
 D) Plasmid DNA
- Q.12 The agent which separates the two strands of DNA in PCR is??**  
 A) DNA ligase  
 B) Primer  
 C) Heat  
 D) Helicase
- Q.13 Cystic fibrosis patient lack a gene that codes for trans-membrane carrier of??**  
 A) Na<sup>+</sup> ions  
 B) Cl<sup>-</sup> ions  
 C) Ca<sup>++</sup> ions  
 D) K<sup>+</sup> ions
- Q.14 The phage commonly used as a vector in genetic engineering is?**  
 A) Lambda phage  
 B) Gamma phage  
 C) T<sub>2</sub> phage  
 D) T<sub>4</sub> phage
- Q.15 Restriction endonucleases are naturally occurring enzymes of:**  
 A) Viruses  
 B) Bacteria  
 C) Fungi  
 D) Plants

## 2014

- Q.16 pBr 322 have antibiotic resistance gene for**  
 A) Ampicillin and aspirin  
 B) Streptomycin and metronidazole  
 C) Ampicillin and Tetracycline  
 D) Penicillin and metronidazole
- Q.17 Cystic Fibrosis affects which one of the following cells of the body?**  
 A) Epithelial cells  
 B) Endothelial cells  
 C) Plasma cells  
 D) Blood cells
- Q.18 The enzymes which act as molecular scissors in recombinant DNA technology is**  
 A) Exonucleoses  
 B) Endonucleoses  
 C) Polymerases  
 D) Reverse transcriptases
- Q.19 Which of the following is the correct sequence of PCR?**  
 A) Heating → Cooling → Add Primer → Copying of strand  
 B) Heating → Add Primer → Cooling → Copying of strand  
 C) Add Primer → Heating → Cooling → Copying of strand  
 D) Cooling → Add Primer → Heating → Copying of strand
- Q.20 When two different pieces of DNA are joined together, the result is which one of the following?**  
 A) Complementary DNA  
 B) Mutated DNA  
 C) Recombinant DNA  
 D) Cloned DNA

## 2015

- Q.21 In cystic fibrosis, liposomes-microscopic vesicles are sued which are coated with:**  
 A) Healthy Gene  
 B) Chromosome  
 C) Protein  
 D) Carbohydrate
- Q.22 The DNA formed by the reverse transcription is called:**  
 A) rDNA  
 B) dDNA  
 C) cDNA  
 D) DNA



- Q.23 Bacterial cells take up recombinant plasmids when they are treated with:**  
A) CaCl<sub>2</sub>  
B) NaCl  
C) KCl  
D) NaOH
- Q.24 Which one of the following is made up of radioactively labelled nucleotides?**  
A) Phage DNA  
B) Genomic Library  
C) Recombinant DNA  
D) Gene Probe
- Q.25 A technique in transgenic animals in which desired gene is inserted into the eggs of animal is called:**  
A) Embryonic Stem Cell mediated Transfer  
B) Microinjection  
C) Retro-virus mediated gene Transfer  
D) Virus vectors

## 2016

- Q.26 The modified plasmid or phage DNA is called:**  
A) Clone DNA  
B) Recombinant DNA  
C) cDNA  
D) rDNA
- Q.27 Restriction endonucleases cleave the \_\_\_\_\_ of duplex DNA.**  
A) Nitrogenous base  
B) Base sugar  
C) Phosphodiester bond  
D) Hydrogen bond
- Q.28 The enzyme which is responsible for the formation of bond between two double stranded DNA fragments is:**  
A) Endonuclease  
B) Urease  
C) Ligase  
D) Helicase
- Q.29 XXXXXXXXXXXXXXXXXXXXXXXXXXXXXXXXXXXXXXXXXXXXXXXXXXXXXXXXXXXXXXX  
XXXXXXXXXXXX.**  
A) XXXXXX  
B) XXXXXX  
C) XXXXXX  
D) XXXXXX

<b>ANSWERS</b>	<b>Q.1</b>	C	<b>Q.9</b>	A	<b>Q.17</b>	A	<b>Q.25</b>	B
	<b>Q.2</b>	B	<b>Q.10</b>	C	<b>Q.18</b>	B	<b>Q.26</b>	B
	<b>Q.3</b>	C	<b>Q.11</b>	A	<b>Q.19</b>	A	<b>Q.27</b>	C
	<b>Q.4</b>	C	<b>Q.12</b>	C	<b>Q.20</b>	C	<b>Q.28</b>	C
	<b>Q.5</b>	B	<b>Q.13</b>	B	<b>Q.21</b>	A	<b>Q.29</b>	<b>X</b>
	<b>Q.6</b>	C	<b>Q.14</b>	A	<b>Q.22</b>	C		
	<b>Q.7</b>	D	<b>Q.15</b>	B	<b>Q.23</b>	A		
	<b>Q.8</b>	C	<b>Q.16</b>	C	<b>Q.24</b>	D		

## 9

## ECOSYSTEM

## 2011

- Q.1 Which one of the following is depleting and causing thinning of ozone?**  
 A) Chlorine  
 B) Bromine  
 C) Chlorofluorocarbon  
 D) Carbon
- Q.2 The typical environment of a particular organism population community is called**  
 A) Niche  
 B) Ecosystem  
 C) Habitat  
 D) Biosphere
- Q.3 Excessive enrichment of water with nutrients by human activity by which large amount of living organic matter grows is called**  
 A) Archeotrophication  
 B) Eutrophication  
 C) Enrichment  
 D) Low Trophication
- Q.4 In an ecosystem, mycorrhizae is an example of**  
 A) Symbiosis  
 B) Predation  
 C) Commensalism  
 D) Parasitism
- Q.5 Successive stages of eating and being eaten by which recycling of materials and flow of energy takes place is called**  
 A) Food Chain  
 B) Food Web  
 C) Trophic Level  
 D) Food Link

## 2012

- Q.6 What is the niche of an organism in an ecosystem?**  
 A) Role played by many organisms in an ecosystem  
 B) Role played by a dead organism in an ecosystem  
 C) Role played by community of microorganisms in their ecosystem  
 D) Role played by an organism in its ecosystem.
- Q.7 The distinct levels or links of food chain are called**  
 A) Trophic level  
 B) Food web  
 C) Energy pyramid  
 D) Food chain
- Q.8 A relationship between two or more organisms of different species in which all partners get benefit is called**  
 A) Symbiosis  
 B) Parasitism  
 C) Commensalism  
 D) Predation
- Q.9 Bacteria and fungi are examples of**  
 A) Producers  
 B) Decomposers  
 C) Consumers  
 D) Denvers
- Q.10 The cause of acid rain is**  
 A) Oxides of carbon  
 B) Oxides of nitrogen and Sulphur  
 C) Oxides of Sulphur  
 D) Oxides of nitrogen

## 2013

- Q.11 In an ecosystem mycorrhizae are an example of:**  
 A) Predation  
 B) Symbiosis  
 C) Mutualism  
 D) Parasitism
- Q.12 As a result of destruction of ozone layer there is significant increase in:**  
 A) Ultra-violet radiations  
 B) Greenhouse gases  
 C) Nitrogen oxide  
 D) Sulphur oxide
- Q.13 Higher rate of a biological activity in a nutrient rich pond water is called:**  
 A) Water pollution  
 B) Air pollution  
 C) Eutrophication  
 D) Industrial effects
- Q.14 Living part of ecosystem is:**  
 A) lithosphere  
 B) Hydrosphere  
 C) Community  
 D) Biosphere
- Q.15 A living association between two living organisms of different species which is beneficial to both the partners is called:**  
 A) Commensalism  
 B) Parasitism  
 C) Mutualism  
 D) Predation

## 2014

- Q.16 Individual successions are known as**  
 A) Primary successions  
 B) Secondary successions  
 C) Seres  
 D) Xeroses
- Q.17 Which one of the following is the ultimate distributional unit within which a species is restrained by the limitations of its physical structure and physiology?**  
 A) Niche  
 B) Biome  
 C) Ecosystem  
 D) Habitat
- Q.18 All herbivores belong to which trophic level in the food chain?**  
 A) T1  
 B) T2  
 C) T3  
 D) T4
- Q.19 How many food chains are present in following food web?**

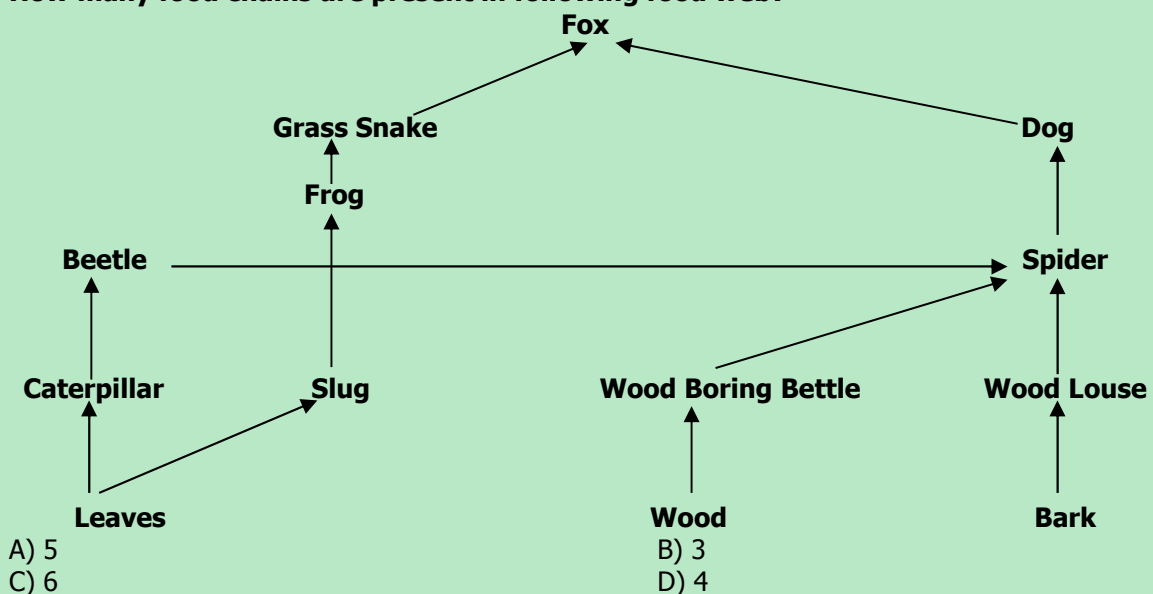

- Q.20 The relationship in which one organism gets benefit and the other is not affected is called**
- A) Mutualism  
B) Commensalism  
C) Predation  
D) Parasitism

## 2015

- Q.21 Ozone is a layer of atmosphere extending from \_\_\_\_\_ km above earth and absorbs ultraviolet radiations.**
- A) 10-50  
B) 50-60  
C) 5-30  
D) 10-80
- Q.22 Light rays from the sun are absorbed by CO<sub>2</sub> and re-radiate as \_\_\_\_\_ radiations.**
- A) Ultraviolet  
B) Indigo  
C) Infra-Red  
D) Green
- Q.23 The gases which are produced by burning of fossils fuels and are responsible for acid rain are:**
- A) CFCs  
B) CO<sub>2</sub> and CO  
C) HCl and Oxides of Nitrogen  
D) SO<sub>2</sub> and Oxides of Nitrogen
- Q.24 During successions, the first organisms that develop on bare rock are:**
- A) Lichens  
B) Shrubs  
C) Moss  
D) Herbs
- Q.25 Trophic level of a herbivore in given food-web is:**

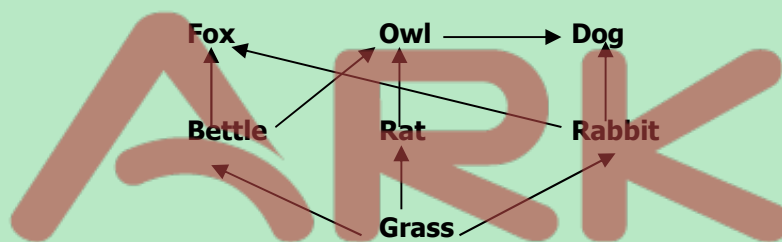

- A) 1  
B) 3  
C) 4  
D) 2

## 2016

- Q.26 The organisms of third trophic level are:**
- A) Primary consumer  
B) Primary producer  
C) Tertiary consumer  
D) Secondary consumer
- Q.27 The ultimate source of energy in an ecosystem is:**
- A) Photosynthesis  
B) Sun  
C) Plants  
D) Water
- Q.28 All the food chains and food webs begin with:**
- A) Detritus  
B) Herbivores  
C) Green plants  
D) Omnivores
- Q.29 The change from bare rock or open area is rapid, especially in the initial stages and follows a series of recognizable and hence predictable stages. This process is called:**
- A) Pioneers  
B) Xerosere  
C) Succession  
D) Secondary succession

**Q.30 The decline in the thickness of ozone layer is caused by:**

- A) Increasing level of nitrogen oxide  
 B) Decreasing level of O<sub>2</sub>  
 C) Decreasing level of CFCs  
 D) Increasing level of CFCs

<b>ANSWERS</b>	<b>Q.1</b>	C	<b>Q.9</b>	B	<b>Q.17</b>	A	<b>Q.25</b>	D
	<b>Q.2</b>	C	<b>Q.10</b>	B	<b>Q.18</b>	B	<b>Q.26</b>	D
	<b>Q.3</b>	B	<b>Q.11</b>	B	<b>Q.19</b>	D	<b>Q.27</b>	B
	<b>Q.4</b>	A	<b>Q.12</b>	A	<b>Q.20</b>	B	<b>Q.28</b>	C
	<b>Q.5</b>	A	<b>Q.13</b>	C	<b>Q.21</b>	A	<b>Q.29</b>	C
	<b>Q.6</b>	D	<b>Q.14</b>	D	<b>Q.22</b>	C	<b>Q.30</b>	D
	<b>Q.7</b>	A	<b>Q.15</b>	C	<b>Q.23</b>	D		
	<b>Q.8</b>	A	<b>Q.16</b>	C	<b>Q.24</b>	A		

 The logo for ARK, featuring the letters 'A', 'R', and 'K' in a stylized, rounded font. The 'A' is a large, light blue letter with a white swoosh underneath it. The 'R' and 'K' are also light blue and rounded.

## 10

## EVOLUTION AND GENETICS

## 2011

- Q.1 The sex of individuals of next generation always depends on one of the parents who is**  
 A) Heterogametic C) Isogametic  
 B) Homogametic D) Isomorphic
- Q.2 Which of the following will be hemophilic?**  
 A)  $X^H X^h$  C)  $X^h Y$   
 B)  $X^H X^H$  D)  $X^H Y$
- Q.3 Which of the following is an example of X-linked recessive trait in humans?**  
 A) Hypophosphatemic Rickets C) Baldness  
 B) Colour Blindness D) Beard Growth
- Q.4 Which trait in human is an example of multiple alleles?**  
 A) Eye Colour C) ABO-Blood Group  
 B) Skin Colour D) Rh-Blood Group
- Q.5 When a gene pair at one locus interacts with another gene at another locus, the interaction is called**  
 A) Dominance C) Pleiotropy  
 B) Multiple Alleles D) Epistasis

## 2012

- Q.6 When the presence of a gene at one locus suppresses the effect of a gene at another locus, the phenomenon is called**  
 A) Hypostasis C) Epistasis  
 B) Pleiotropy D) Epitropy
- Q.7 The gene for ABO-blood group systems in humans is represented by symbol:**  
 A) X C) Y  
 B) I D) O
- Q.8 When a single gene affects two or more traits, the phenomenon is called**  
 A) Epistasis C) Dominance  
 B) Pleiotropy D) Over dominance
- Q.9 The comparative embryology of all vertebrates shows development of**  
 A) Hairs C) Scales  
 B) Gill pouches D) Fins
- Q.10 In men, sex-determination depends upon the nature of**  
 A) Heterogametic male C) Heterogametic female  
 B) Homogametic female D) Homogametic male

## 2013

- Q.11 The structures which are reduced during the course of evolution and have no apparent function are called:**  
 A) Regenerated organs  
 B) Vestigial organs  
 C) Saltatory organs  
 D) Useless organs
- Q.12 When a gene suppresses the effect of another gene at another locus the phenomenon is termed as:**  
 A) Over dominance  
 B) Pleiotropy  
 C) Epistasis  
 D) Co-dominance
- Q.13 Phenylketonuria is an example of:**  
 A) Polyploidy  
 B) Transmutation  
 C) Inversion  
 D) Point mutation
- Q.14 A situation in which one gene affects two or more unrelated characters is called:**  
 A) Epistasis  
 B) Pleiotropy  
 C) Dominance relation  
 D) Polygenes
- Q.15 The mutation which causes change in the sequence of DNA is called:**  
 A) Point mutation  
 B) Chromosomal mutation  
 C) Deletion  
 D) Inversion

## 2014

- Q.16 When a gene expresses the effects of a gene at another focus, this is known as**  
 A) Epistasis  
 B) Co-dominance  
 C) Complete dominance  
 D) Mutation
- Q.17 In male the sex determining gene is**  
 A) XY  
 B) SRY  
 C) SYX  
 D) SXX
- Q.18 A gene which affects two or more unrelated characteristics is called**  
 A) Pleiotropic  
 B) Epistatic  
 C) Dominant  
 D) Mutant
- Q.19 Position of a gene within a DNA molecule is**  
 A) Locus  
 B) Origin  
 C) Amplicon  
 D) Filial
- Q.20 Sickle cell anemia is a type of**  
 A) Insertion  
 B) Transposition  
 C) Deletion  
 D) Base Substitution

## 2015

- Q.21 X-linked recessive trait is:**  
 A) Hypophosphatemia  
 B) Vitamin-D resistant rickets  
 C) Haemophilia  
 D) Diabetes Mellitus
- Q.22 Human skin colour is a good example of?**  
 A) Sex-linked inheritance  
 B) Polygenic inheritance  
 C) x-linked inheritance  
 D) y-linked inheritance

- Q.23 From evolutionary point of view, which respiratory protein is common in many organisms?**  
 A) Cytochrome a C) Cytochrome c  
 B) Cytochrome b D) Cytochrome d
- Q.24 Number of pairs of autosomes in humans in:**  
 A) 23 C) 21  
 B) 24 D) 22
- Q.25 ABO blood system is an example of:**  
 A) Polygenes C) Multiple Alleles  
 B) Multiple genes D) Multiple Mutation

## 2016

- Q.26 Which one of the following is considered as strong evidence of evolution?**  
 A) Embryology Record C) Biochemical Record  
 B) Molecular Record D) Fossil Record
- Q.27 Structures found in different species which are believed to have a common evolutionary origin are called:**  
 A) Homologous C) Vestigial  
 B) Analogous D) Fossilized
- Q.28 Which one of the following is X-linked trait?**  
 A) Male pattern baldness C) Haemophilia  
 B) Diabetes mellitus D) Erythroblastosis fetalis
- Q.29 A character determined by three alleles is:**  
 A) Human skin colour C) Human eye colour  
 B) Human blood group D) Human Rh factor
- Q.30 The total number of genes in a population is called:**  
 A) Gene pool C) Genome  
 B) Allele pool D) Genomic library

<b>ANSWERS</b>	<b>Q.1</b>	A	<b>Q.9</b>	B	<b>Q.17</b>	B	<b>Q.25</b>	C
	<b>Q.2</b>	C	<b>Q.10</b>	A	<b>Q.18</b>	A	<b>Q.26</b>	D
	<b>Q.3</b>	B	<b>Q.11</b>	B	<b>Q.19</b>	A	<b>Q.27</b>	A
	<b>Q.4</b>	C	<b>Q.12</b>	C	<b>Q.20</b>	D	<b>Q.28</b>	C
	<b>Q.5</b>	D	<b>Q.13</b>	D	<b>Q.21</b>	C	<b>Q.29</b>	B
	<b>Q.6</b>	C	<b>Q.14</b>	B	<b>Q.22</b>	B	<b>Q.30</b>	A
	<b>Q.7</b>	B	<b>Q.15</b>	A	<b>Q.23</b>	C		
	<b>Q.8</b>	B	<b>Q.16</b>	A	<b>Q.24</b>	D		



